

Assemble Me . Ride Me

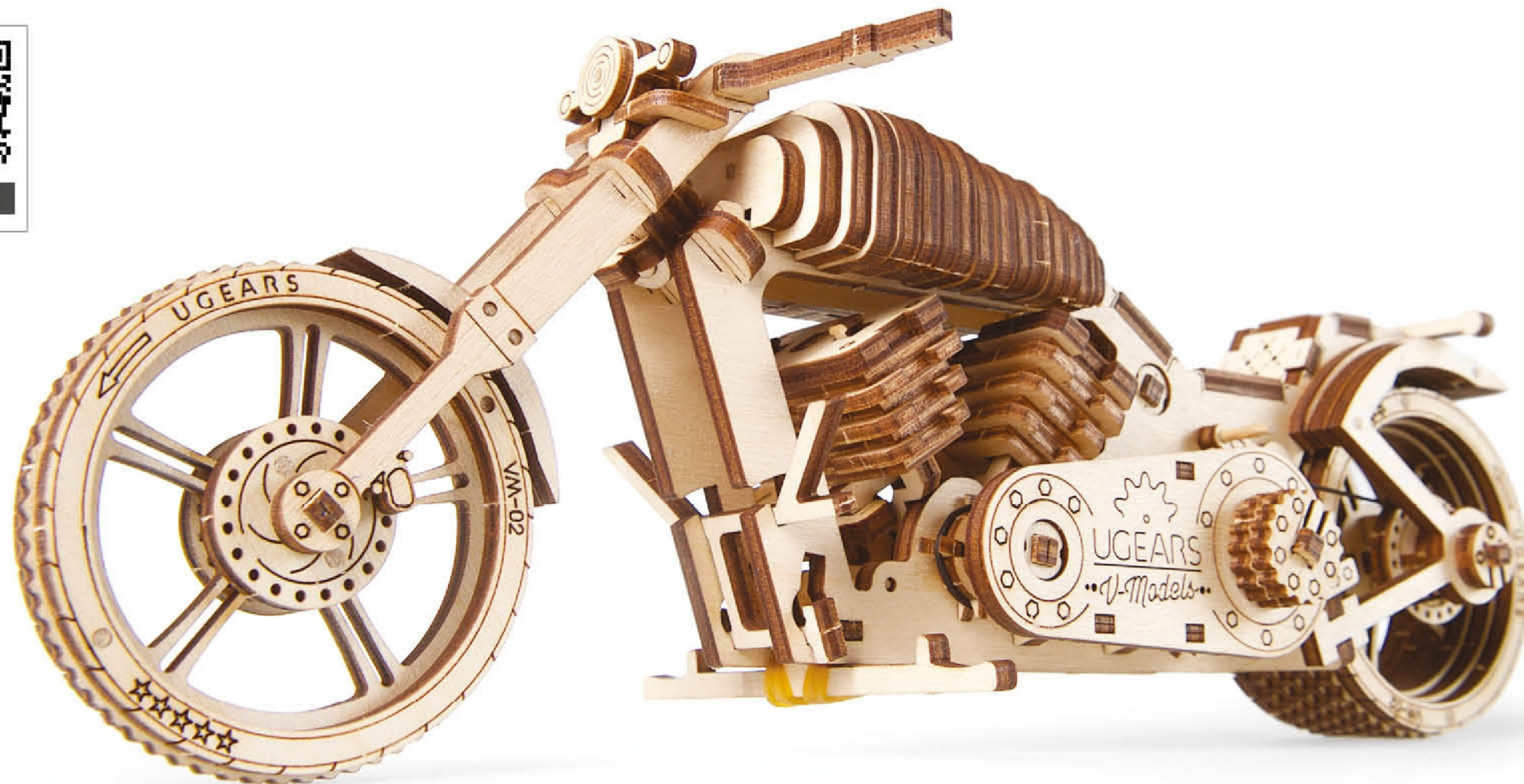

UGEARS
V-Models

"Motorfiets VM-02"

DEU Modell «Motorrad VM-02». FRA Modèle «Moto VM-02». POL Model «Motocykl VM-02». SPA Modelo «La moto VM-02». ITA Modello «Moto VM-02». TUR Model «Motosiklet VM-02». RUS Модель «Байк VM-02». KOR 오토바이 VM-02. CHI 摩托车 VM-02.

Handleiding in het Nederlands

DEU Aufbauanleitung. FRA Notice d'assemblage. POL Instrukcja montażu. SPA Instrucciones de montaje. ITA Istruzioni di montaggio. TUR Kurulum talimatı. RUS Инструкция по сборке. KOR 조립 설명서. CHI 装配说明书



NED

Bouwinstructies.

Verwijder de onderdelen van de borden zoals hieronder is geïllustreerd. Pas op dat de onderdelen niet breken. Wanneer het niet loskomt, gebruik dan voorzichtig een mesje. Dit model bouwt u zelf zonder gebruik te maken van lijm. Wanneer onderdelen moeilijk te plaatsen zijn. Smeer deze dan in met een kaars. Om frictie te voorkomen behandelt u ook alle beweegbare onderdelen met een kaars.

Waarschuwing!



Gebruik geen kaars die brand!



Opgepast, de spieën zijn scherp!

Pictogrammen



Smeer het onderdeel in met kaarsvet.



Opgelet! Controleer de goede positie.



Het onderdeel moet gemakkelijk te draaien zijn.



Schuur om de bramen te verwijderen.



Breek of snij het onderdeel uit.

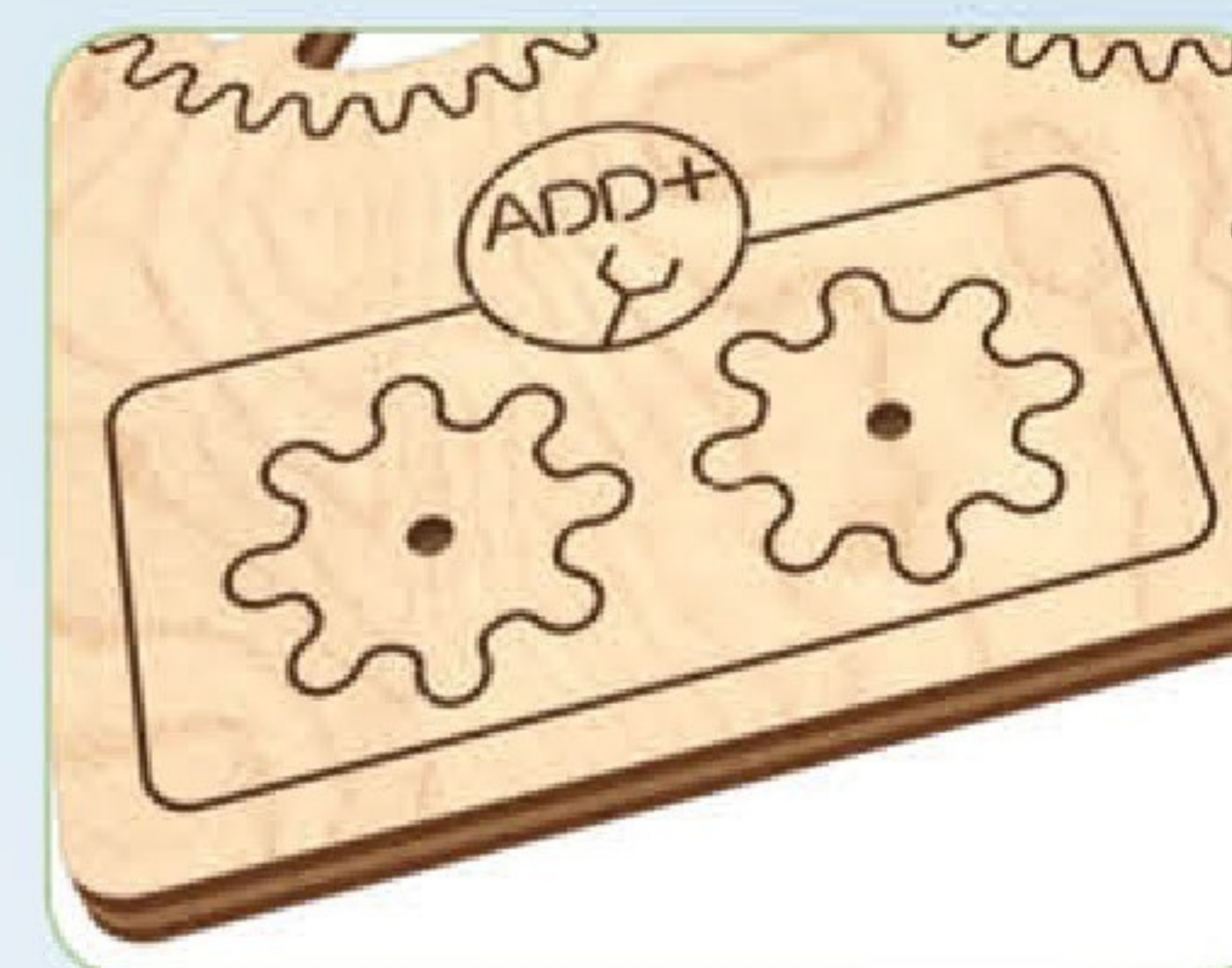

Reserveonderdelen

Dit is geen onderdeel. Het is een gereedschap voor meting en montage. Leder model heeft z'n eigen gereedschap.

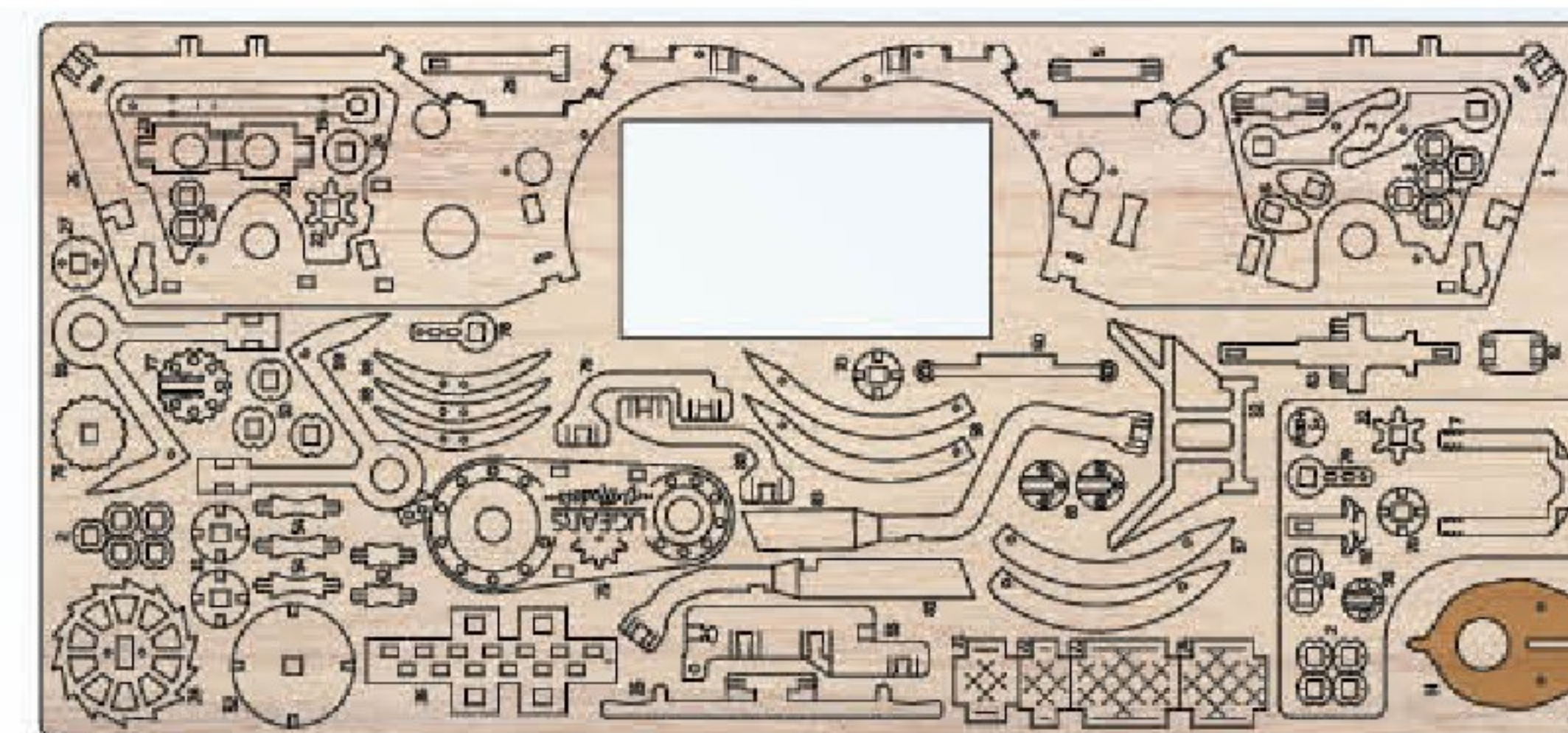

2



3

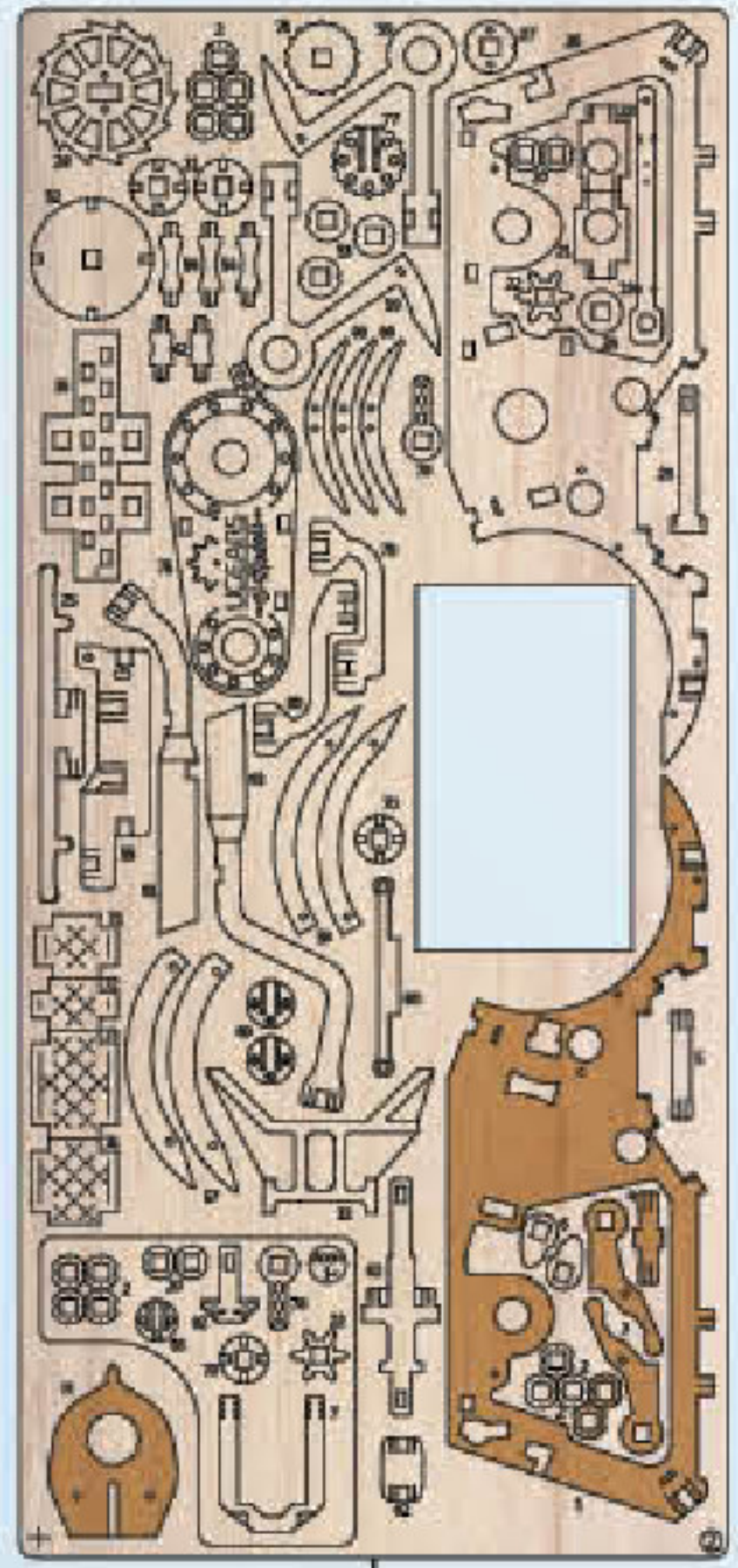

2

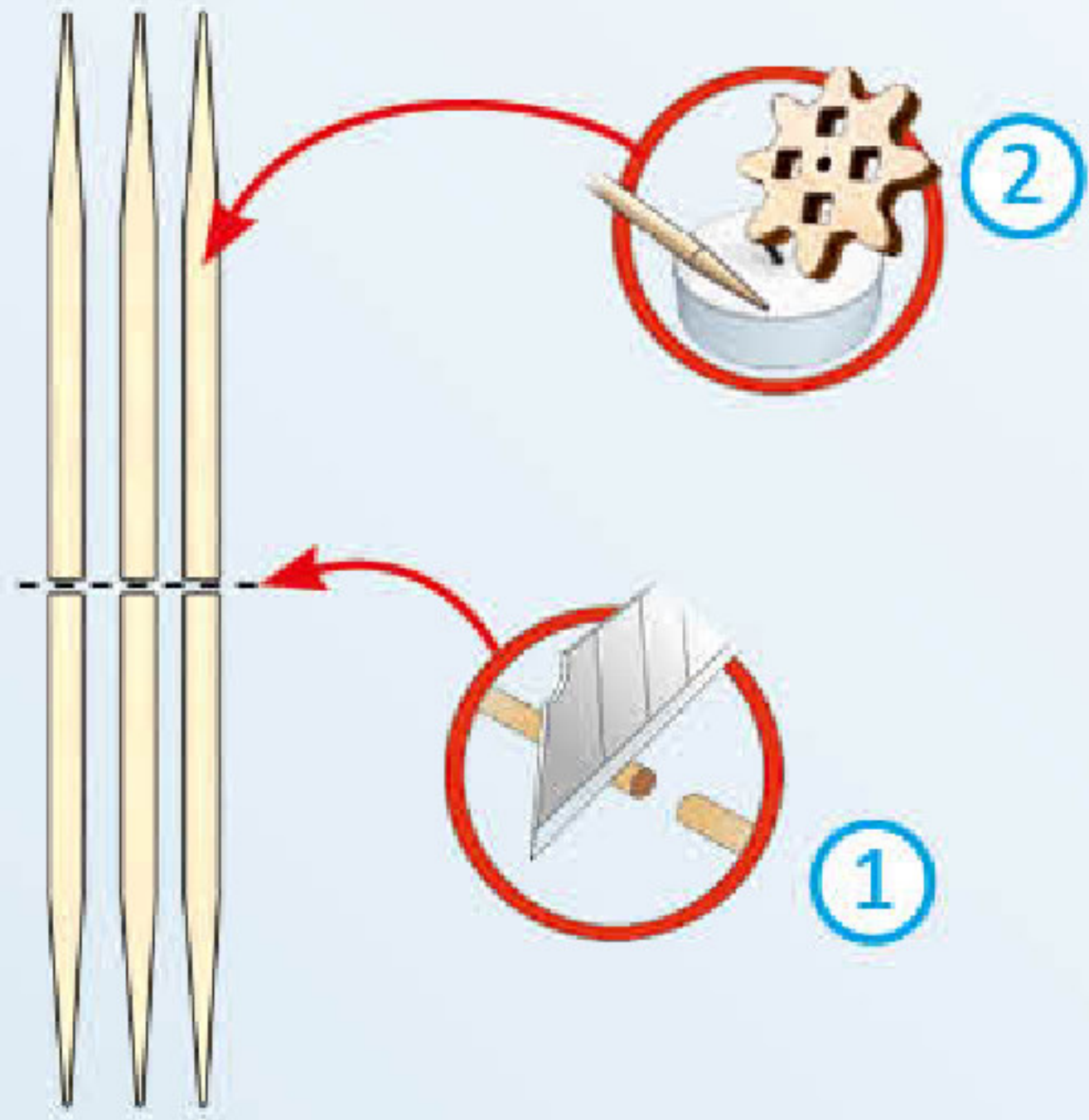

1

2

1

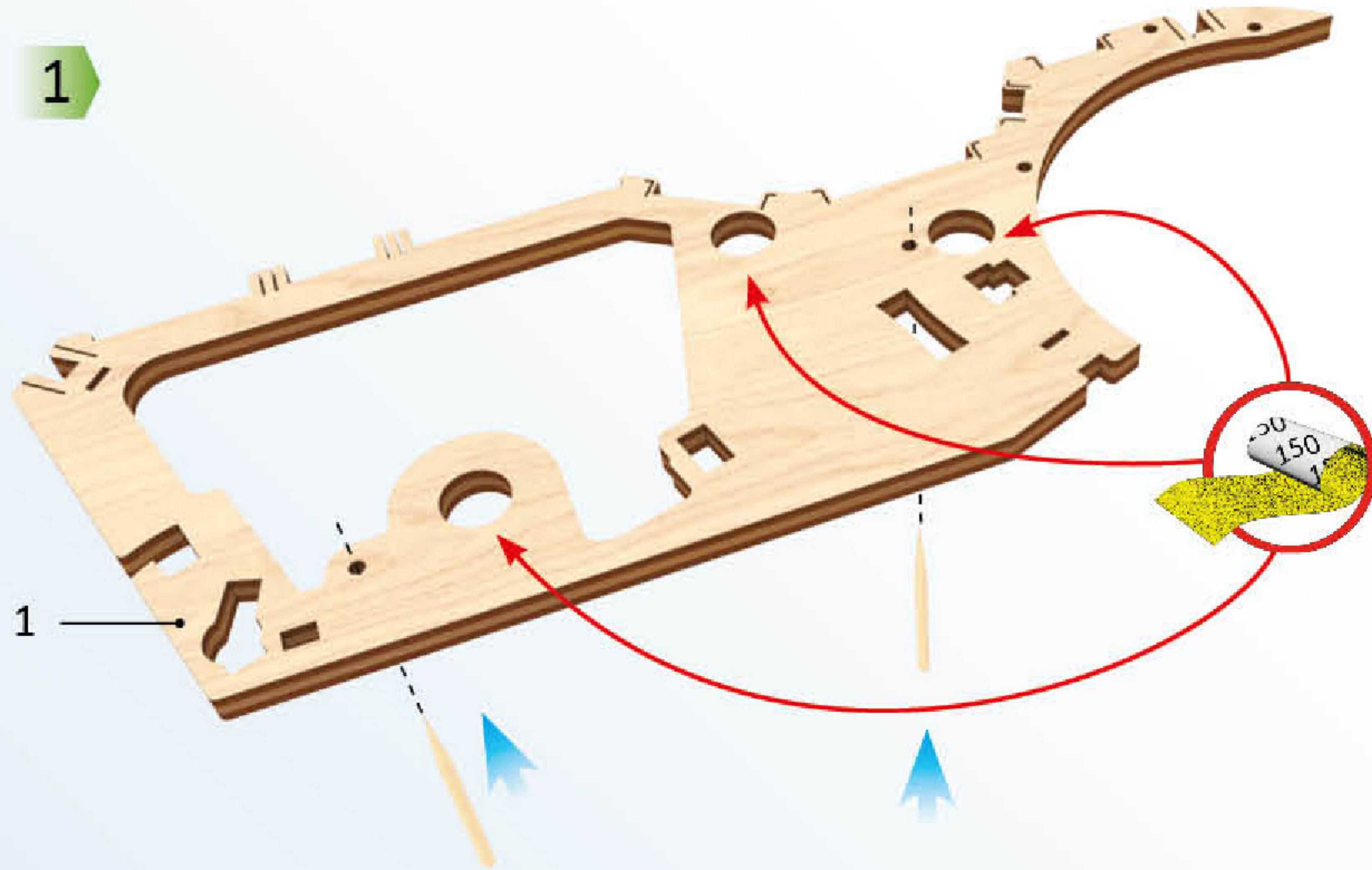

2

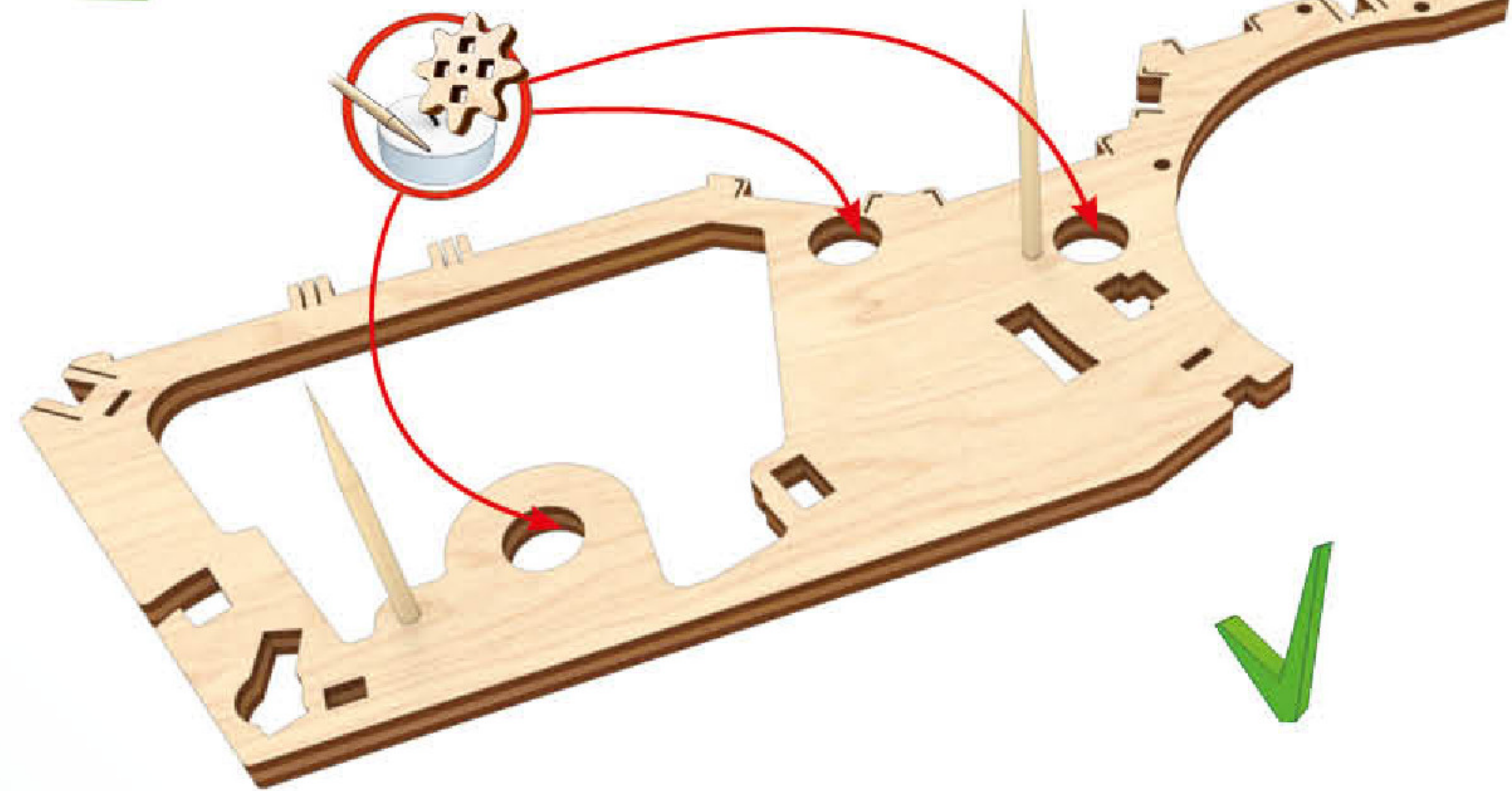

1

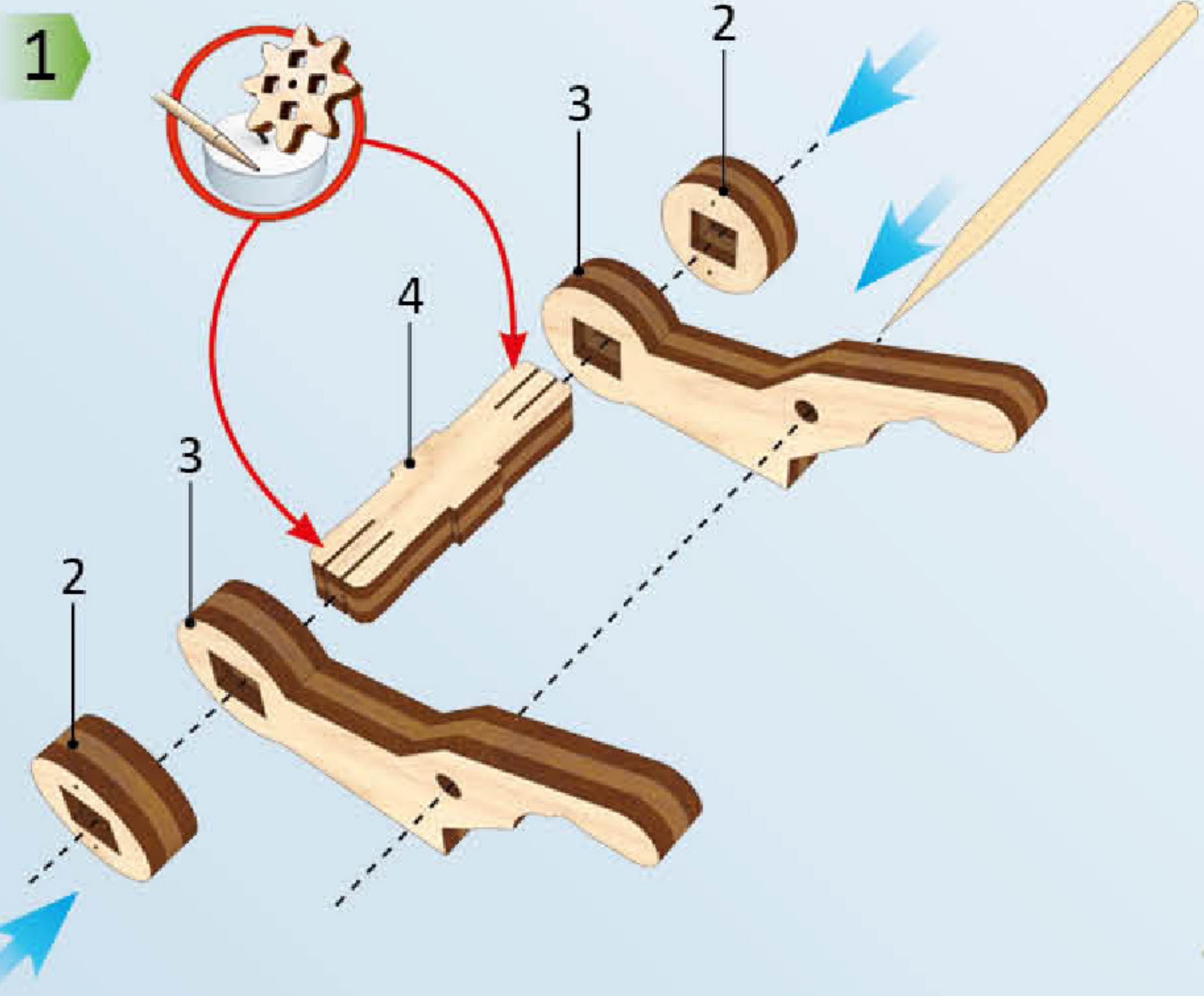

2



1



2

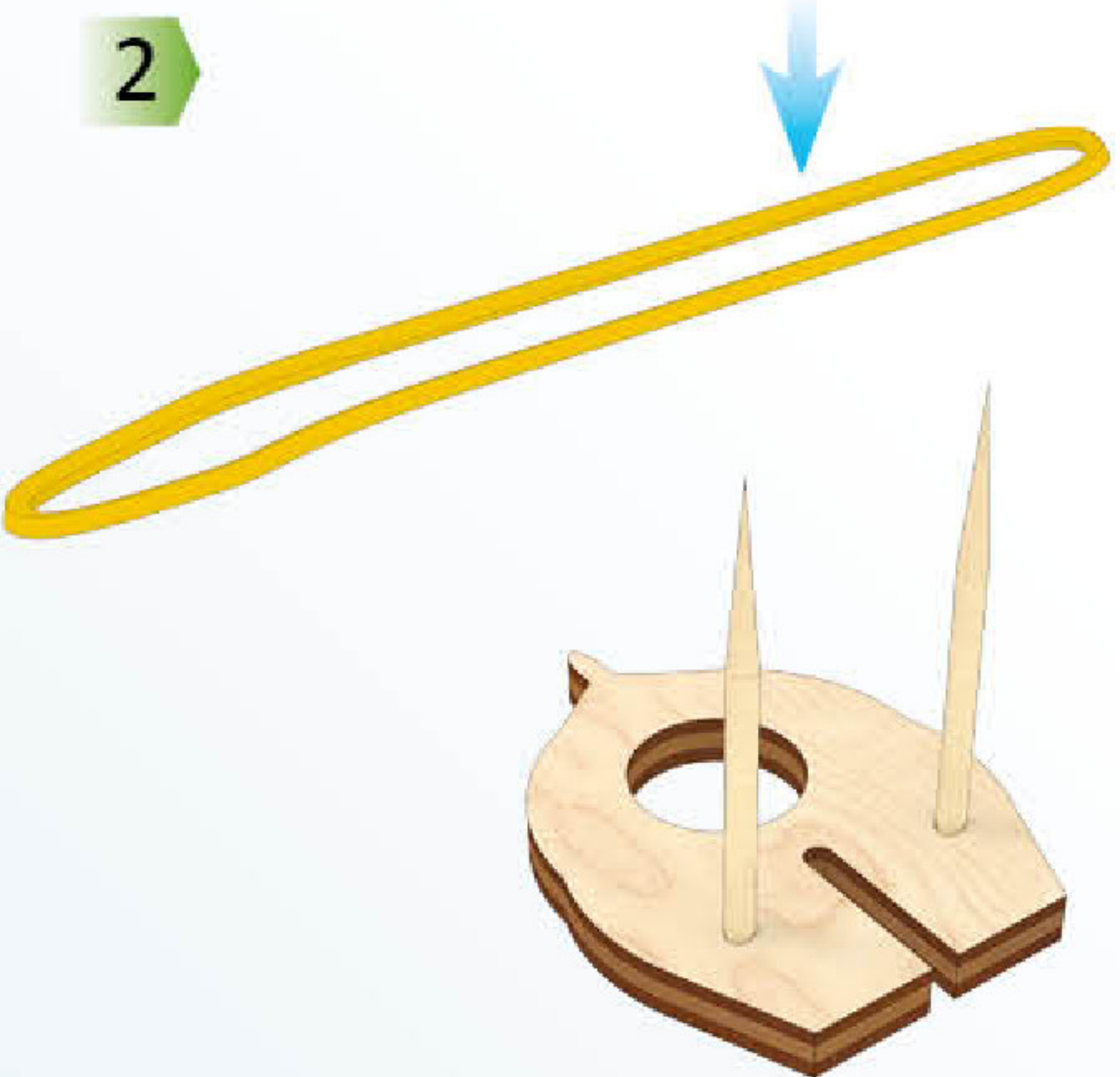

3

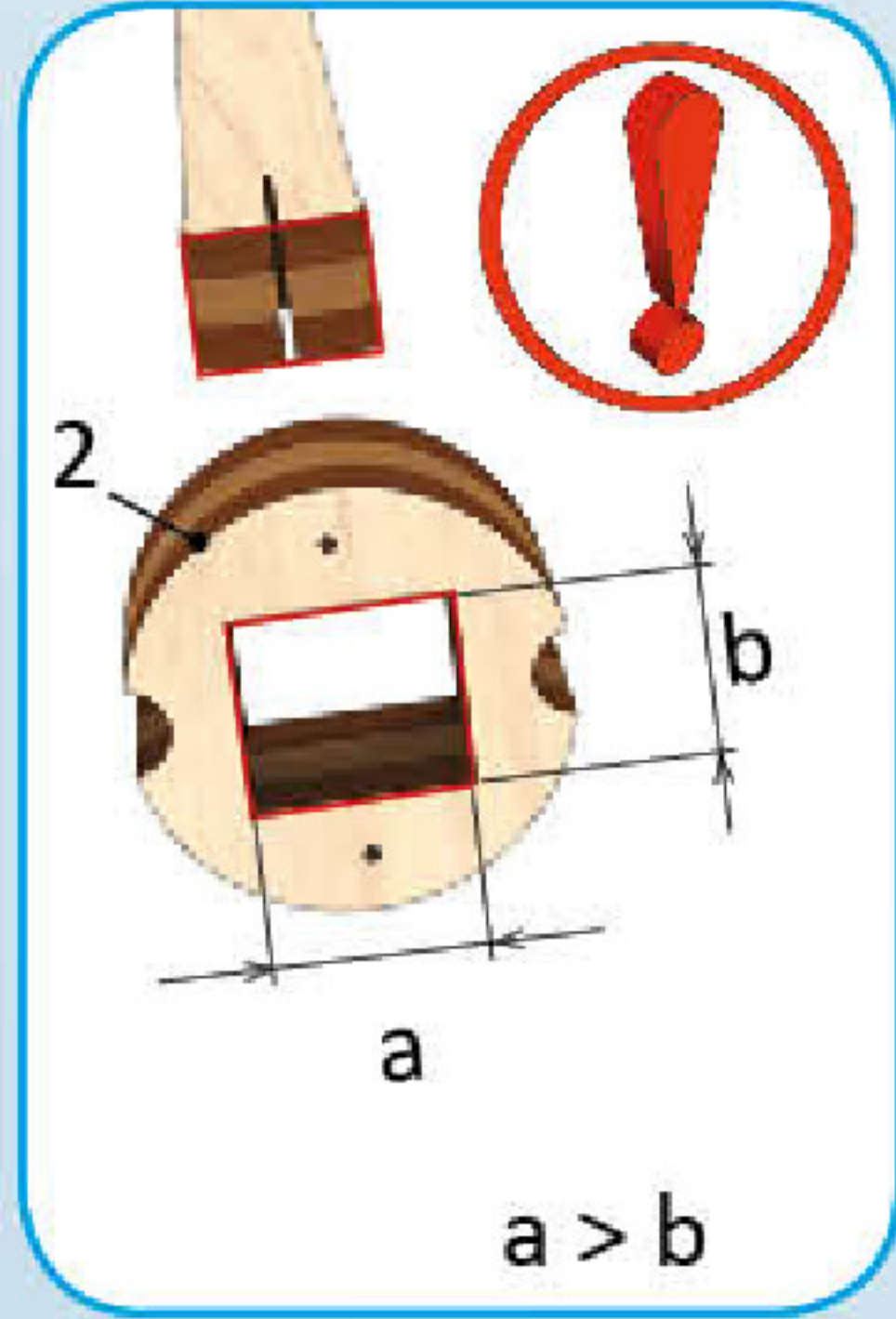
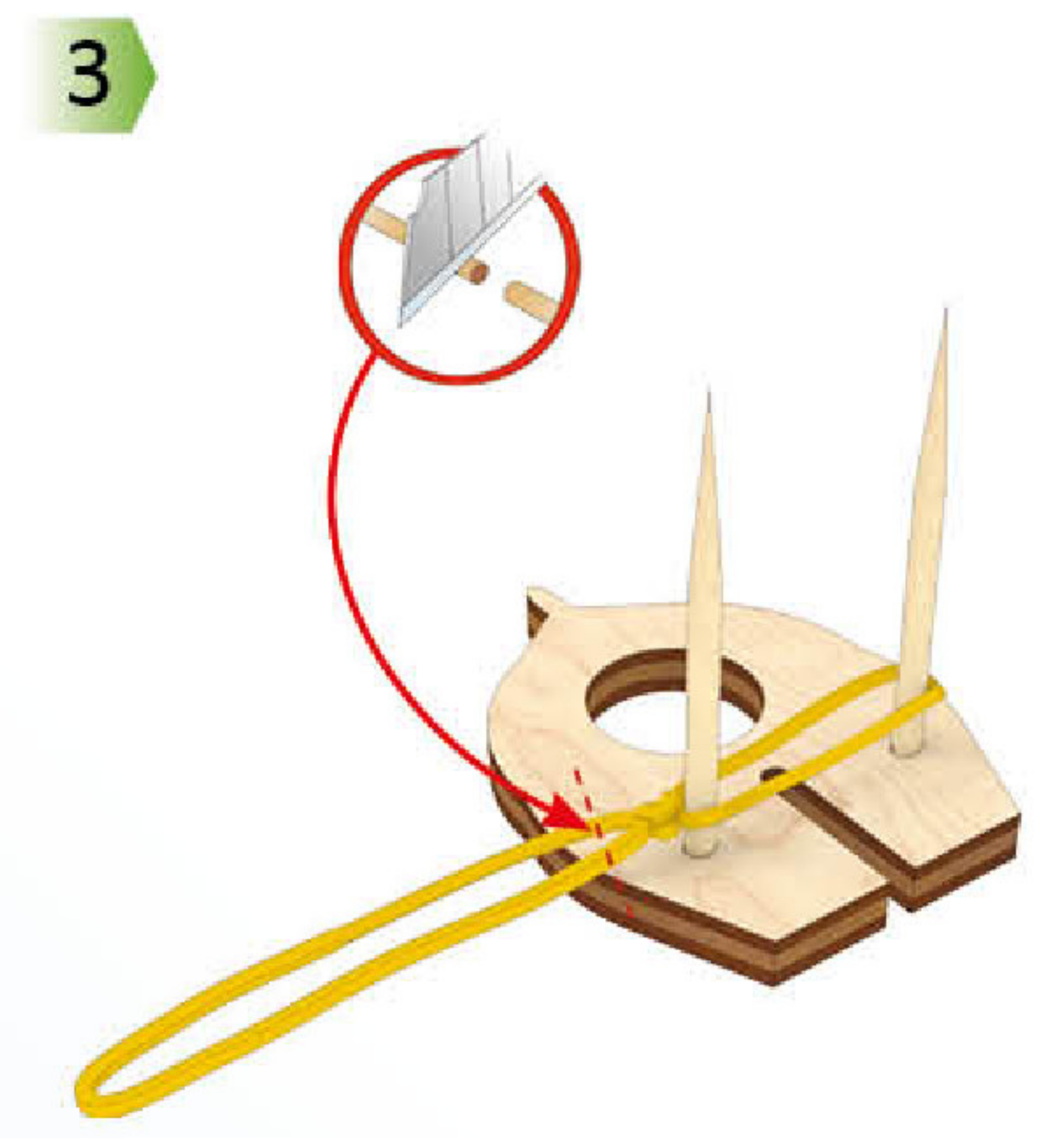

a > b

4

1

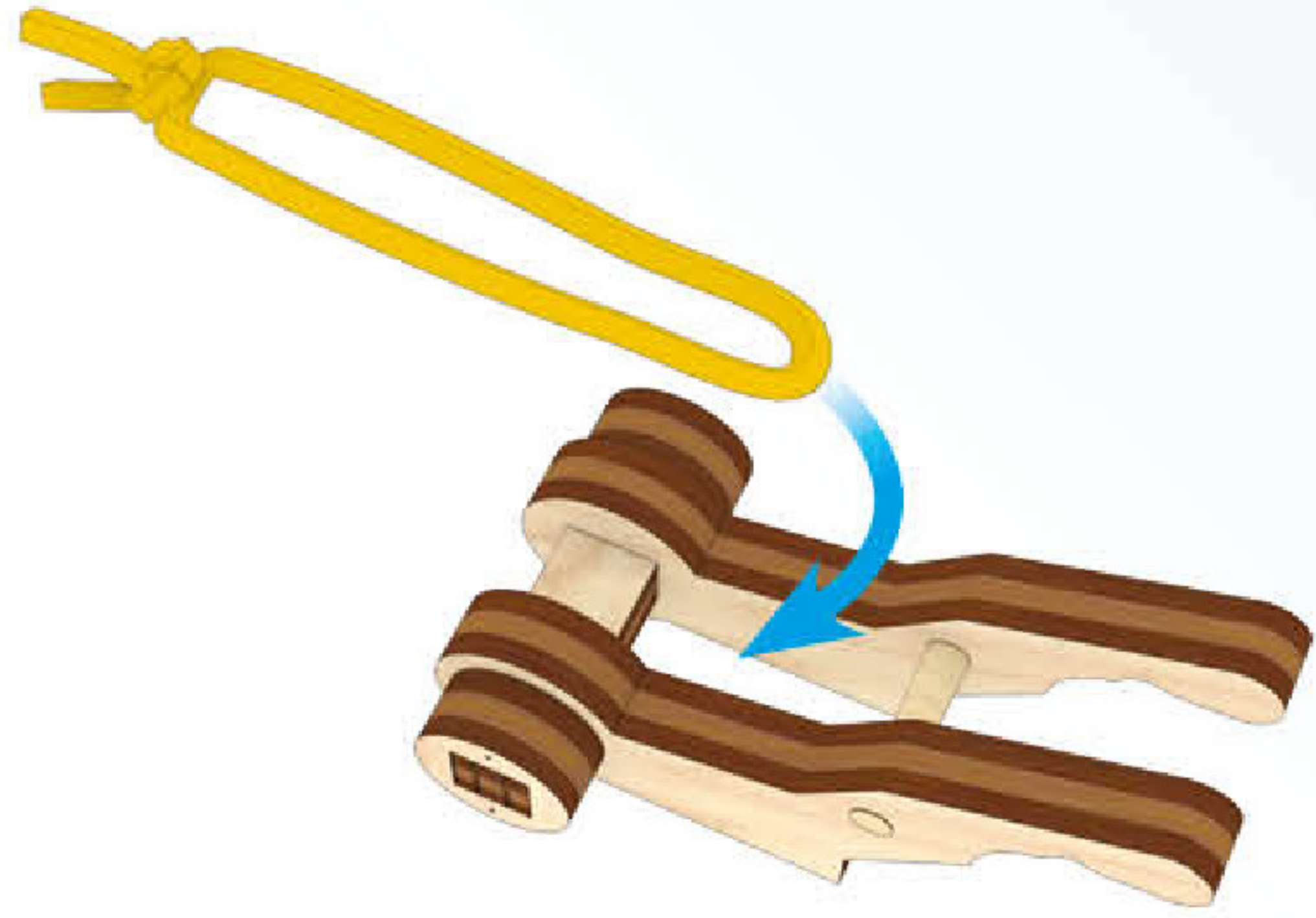

2

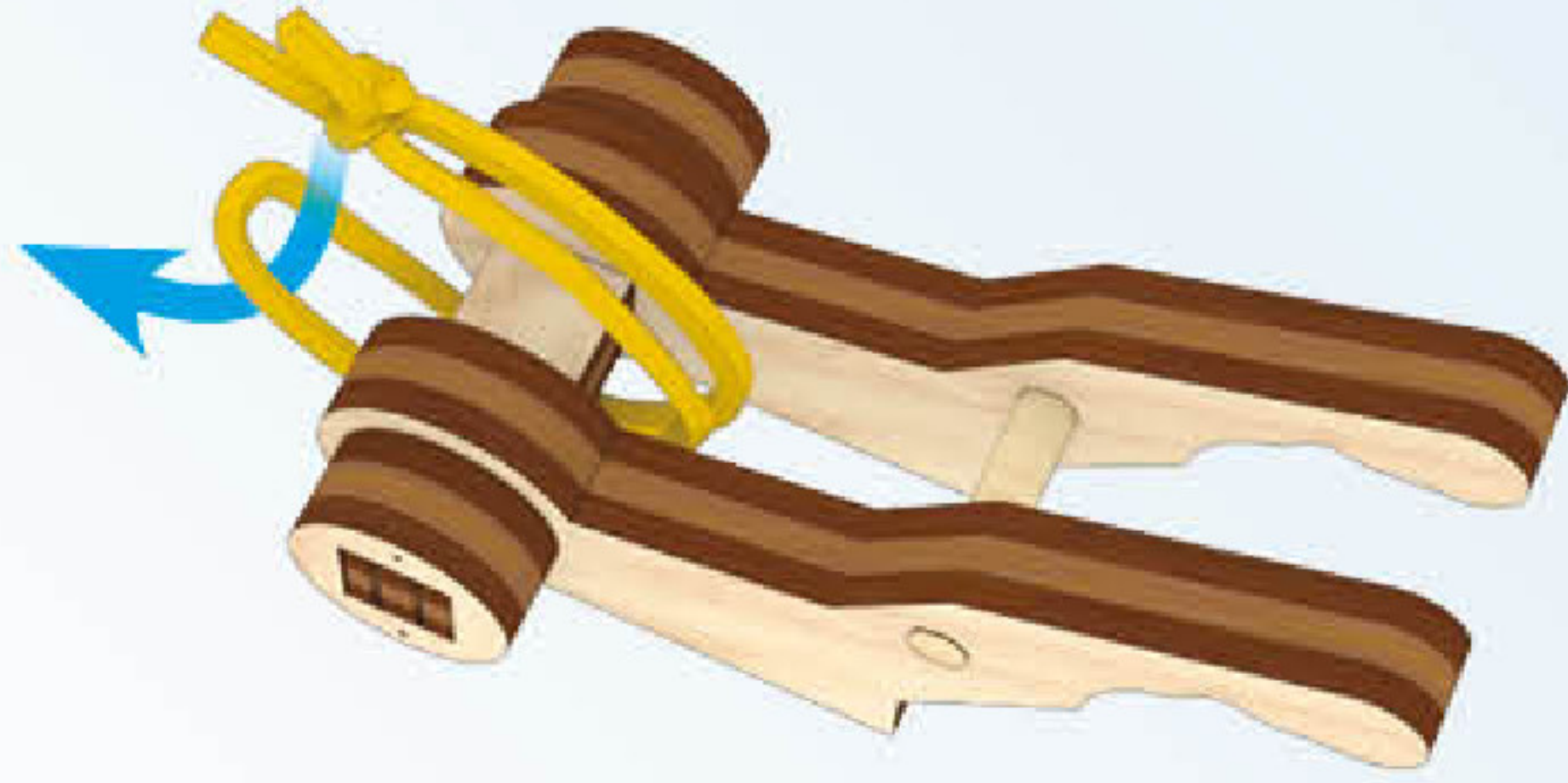

3

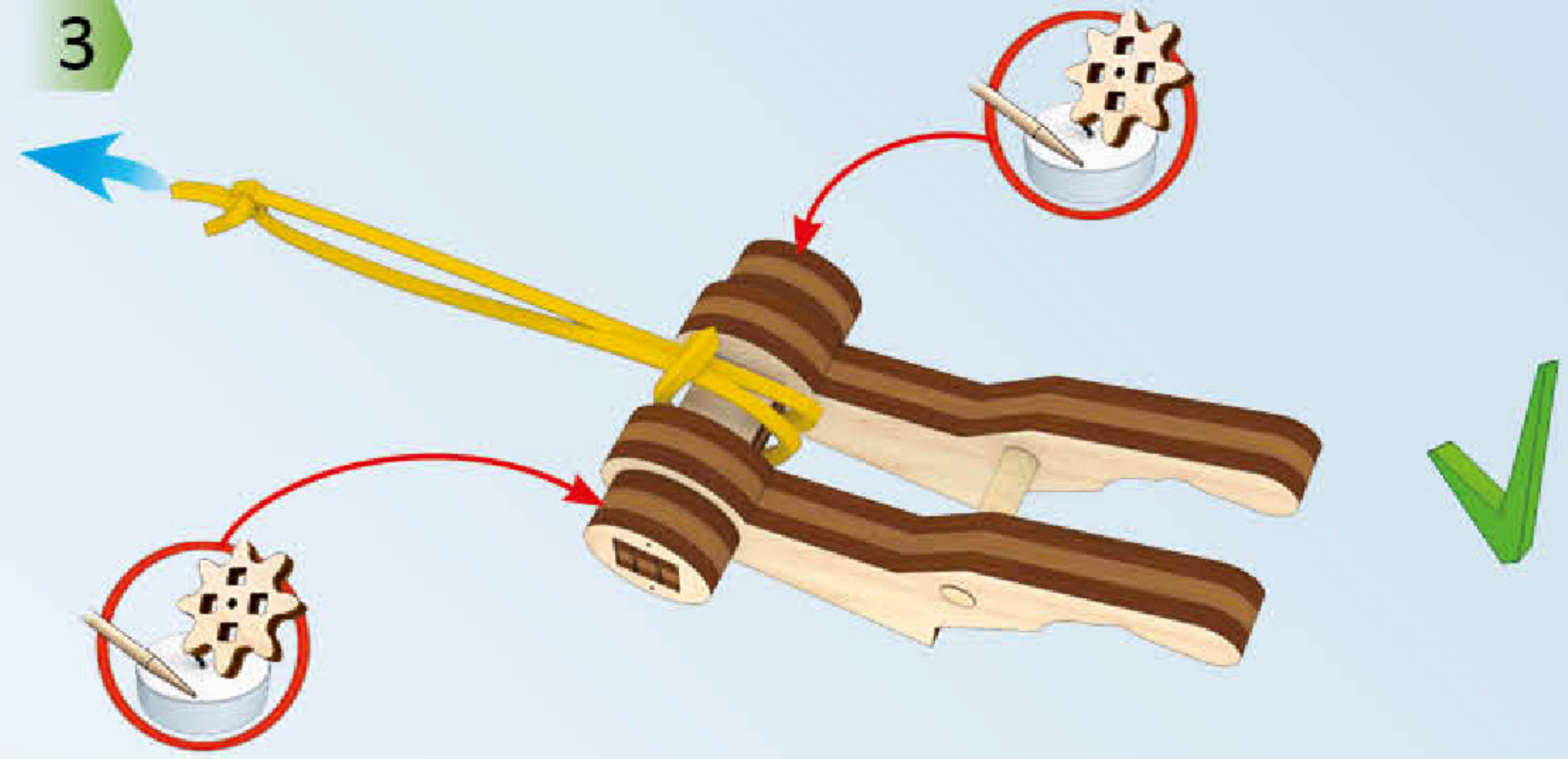

1

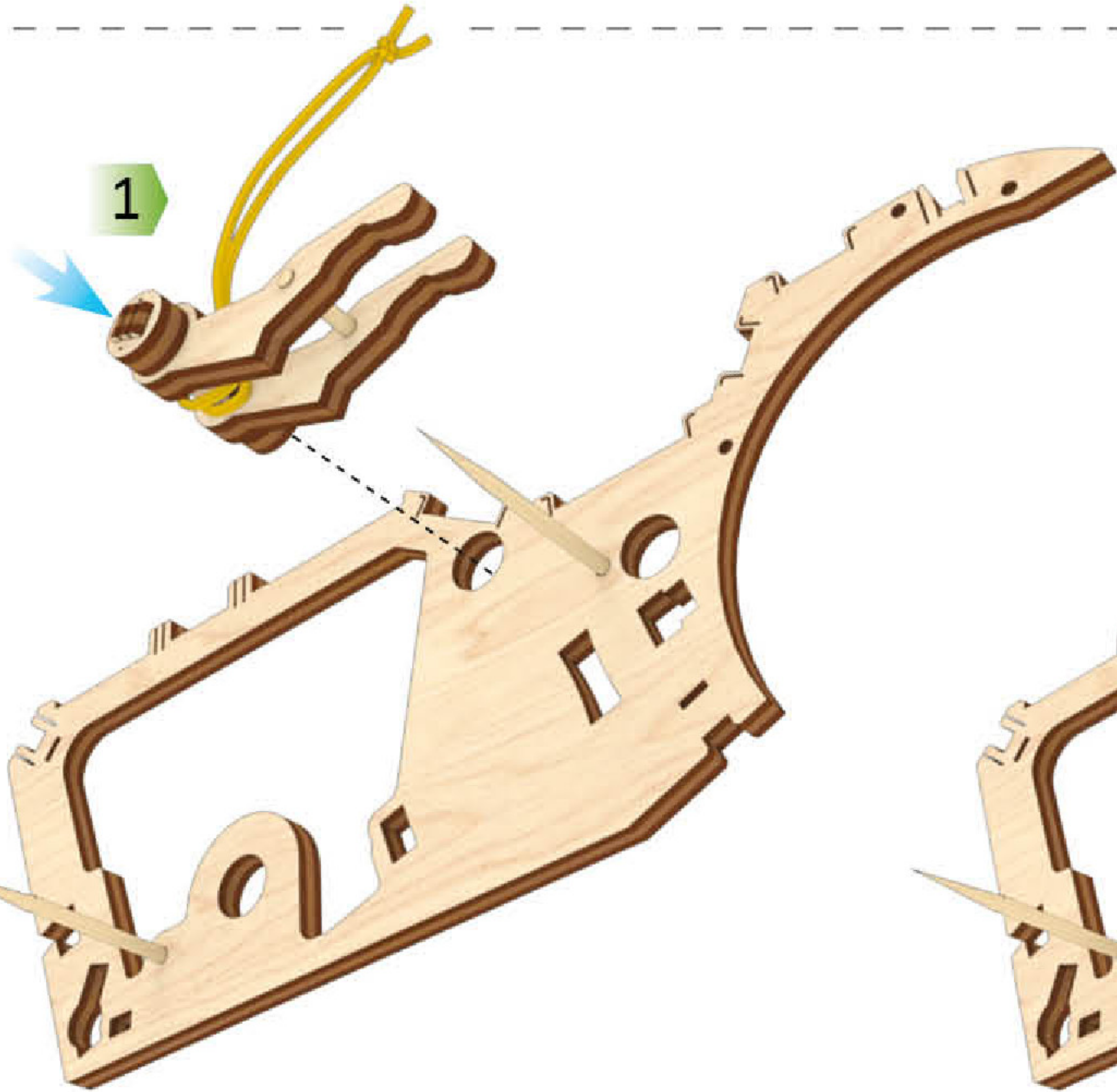

2

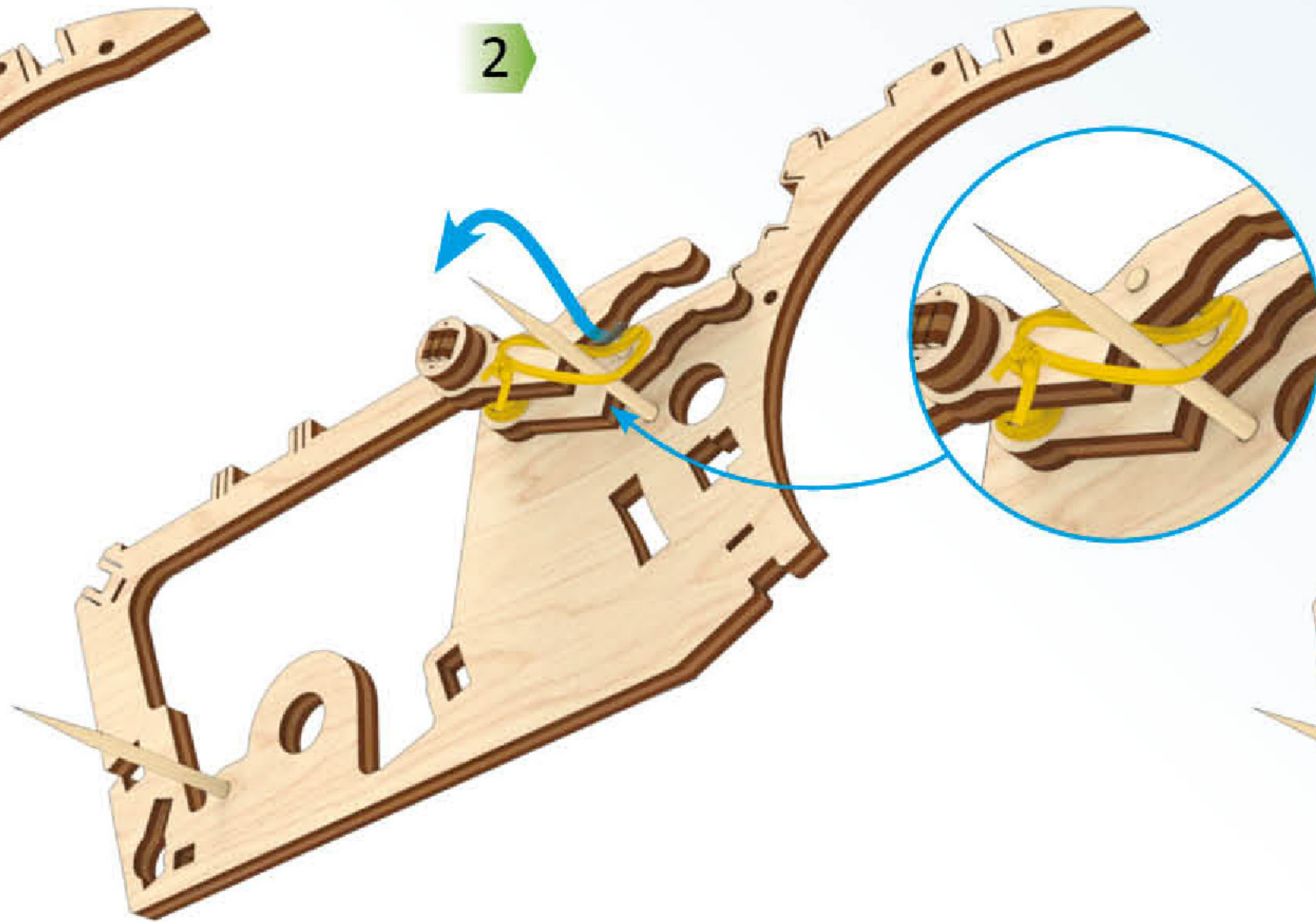

3

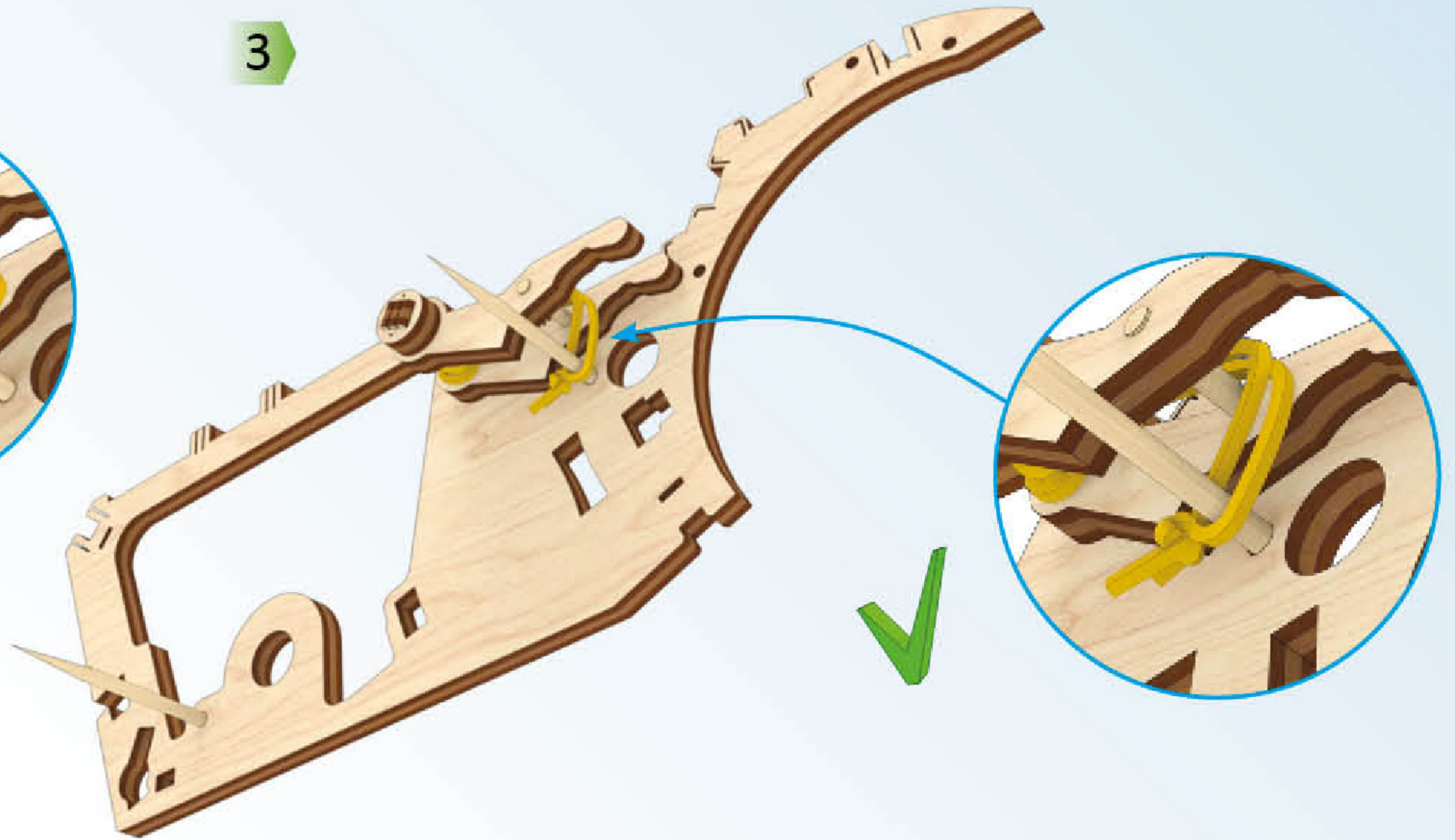

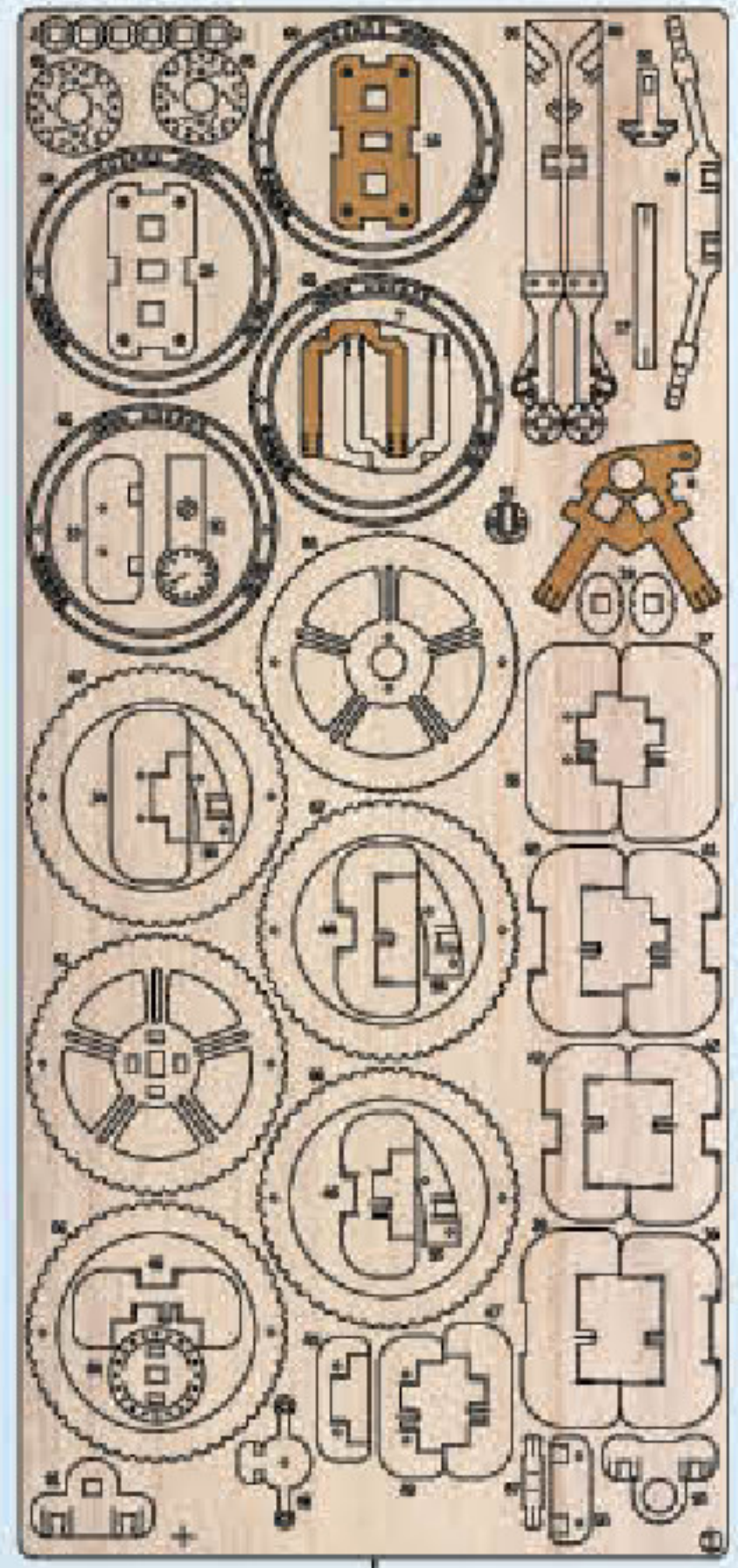

1

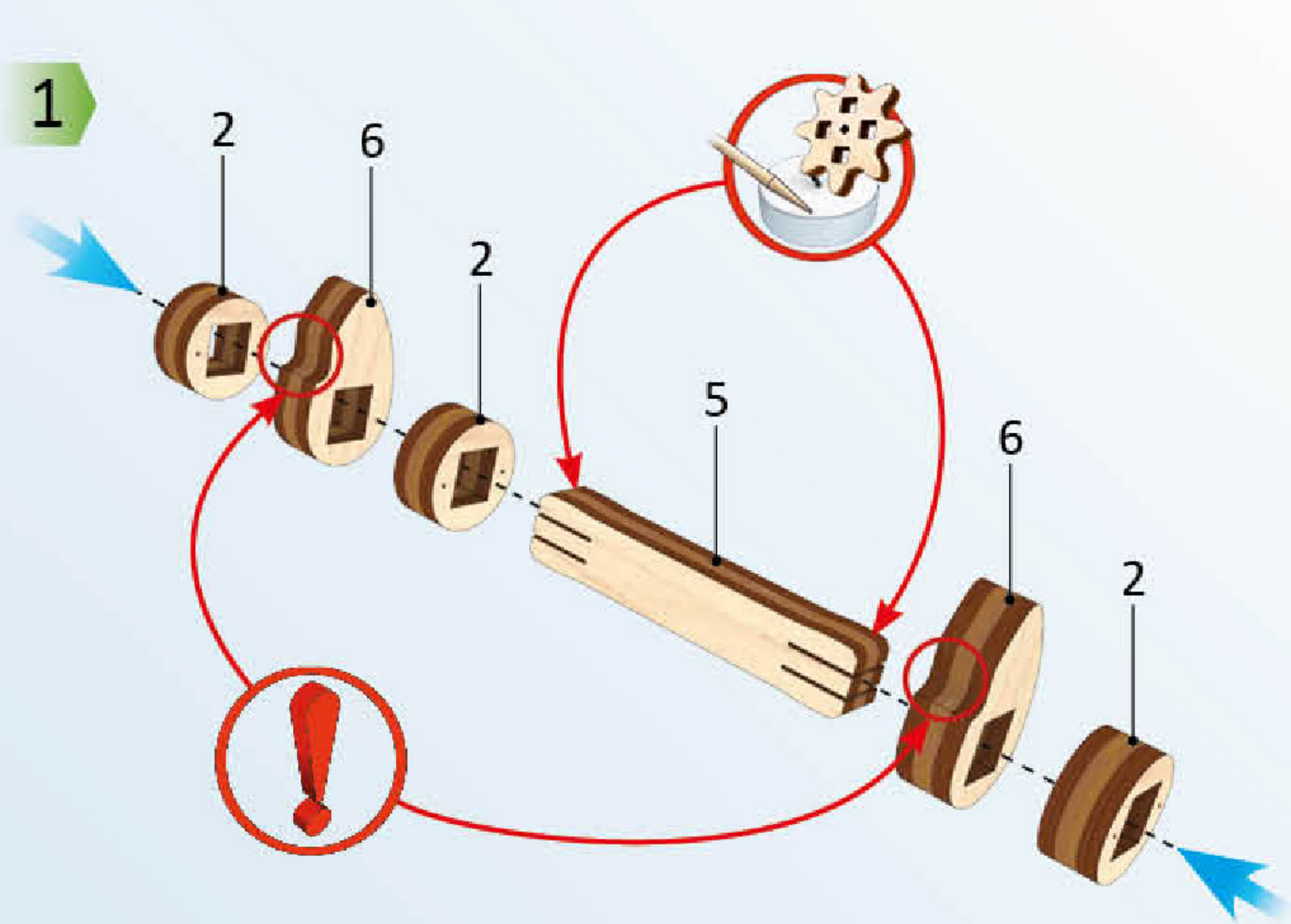

2

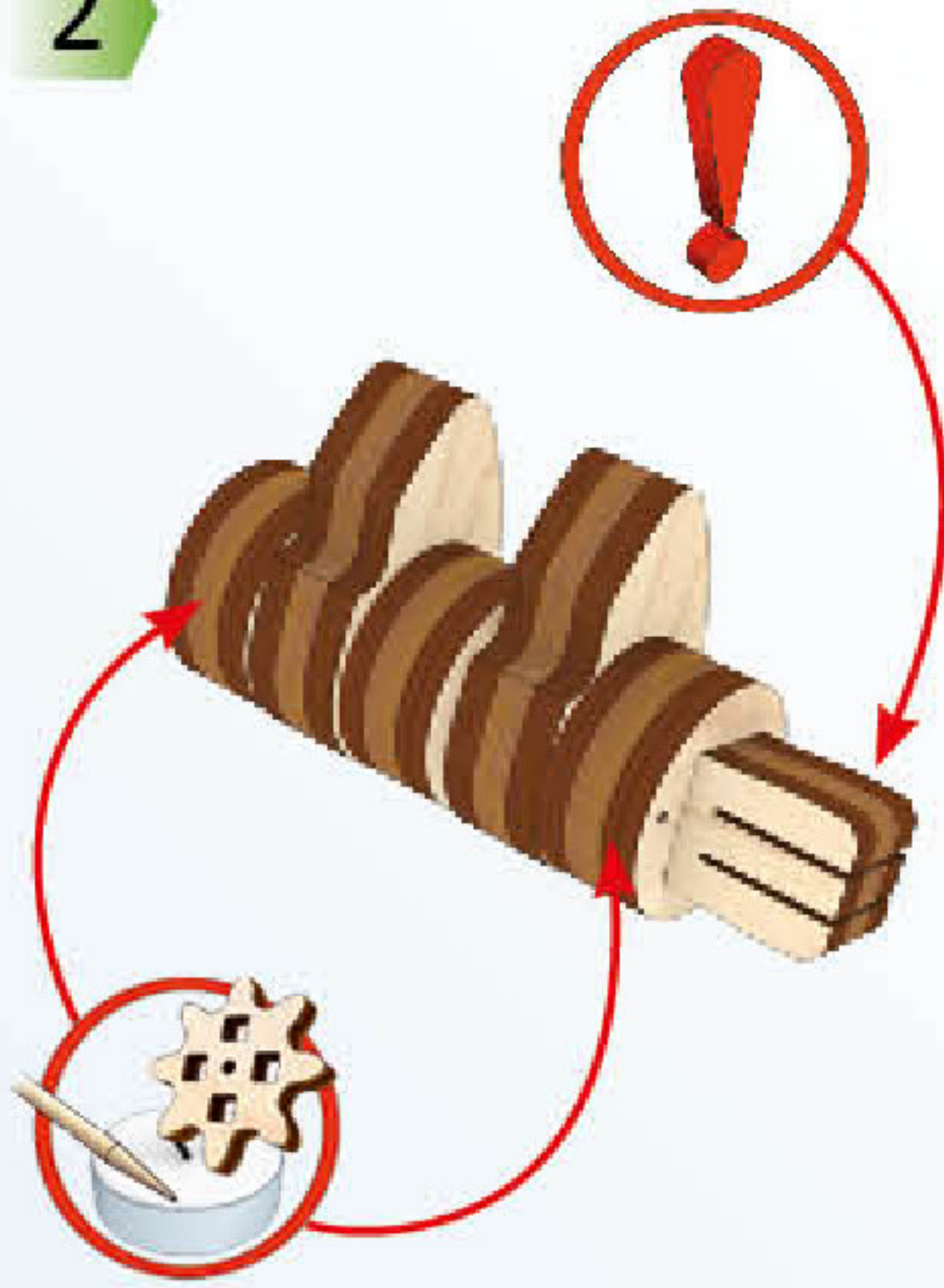

3

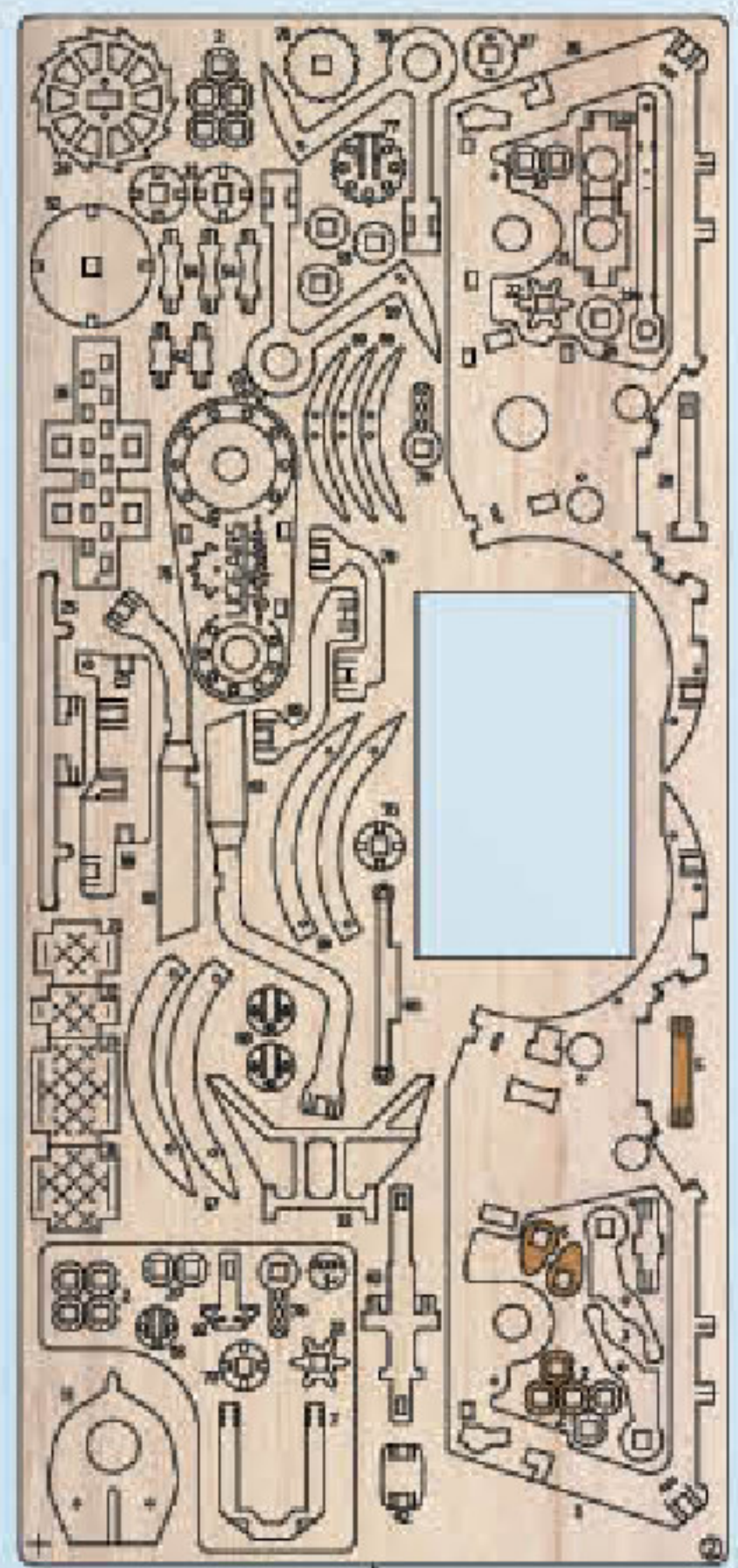
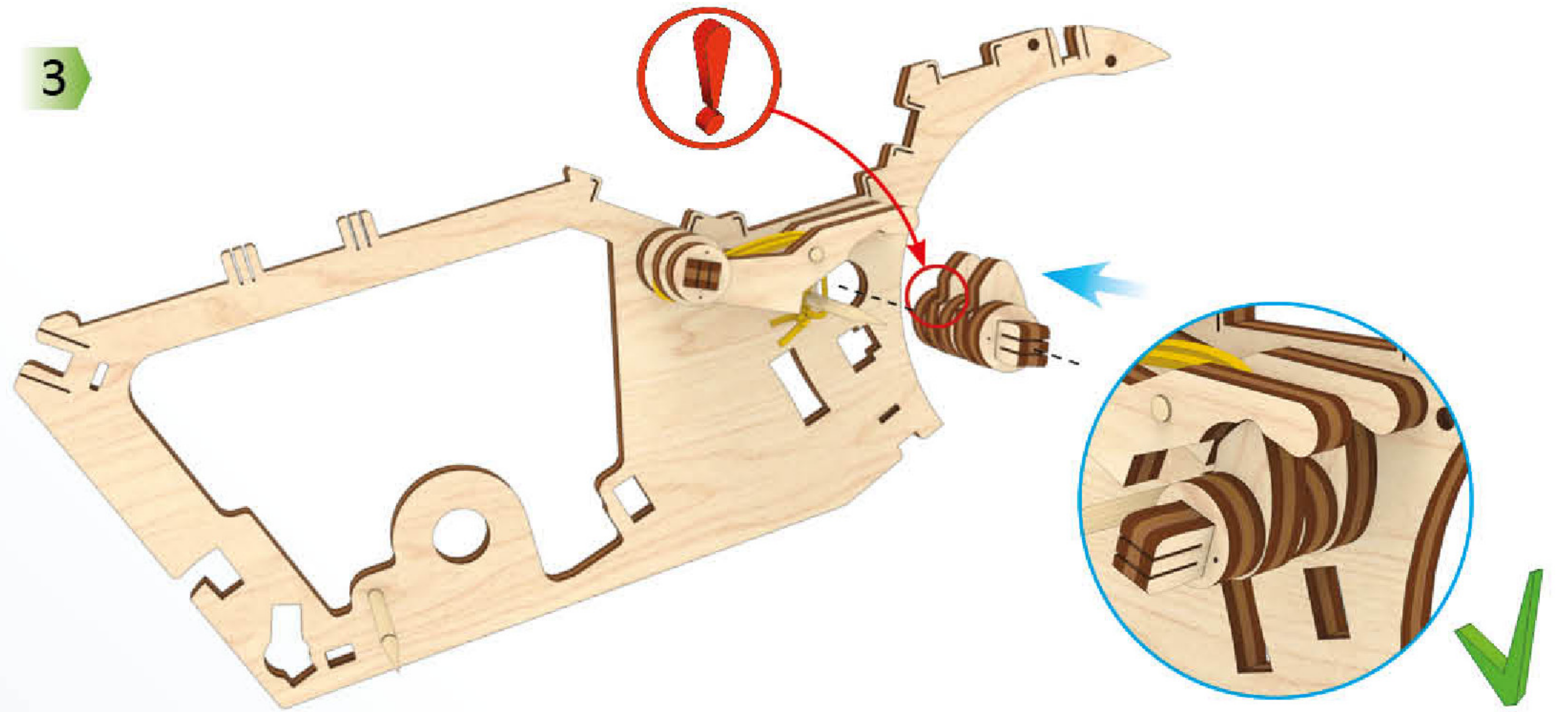

2

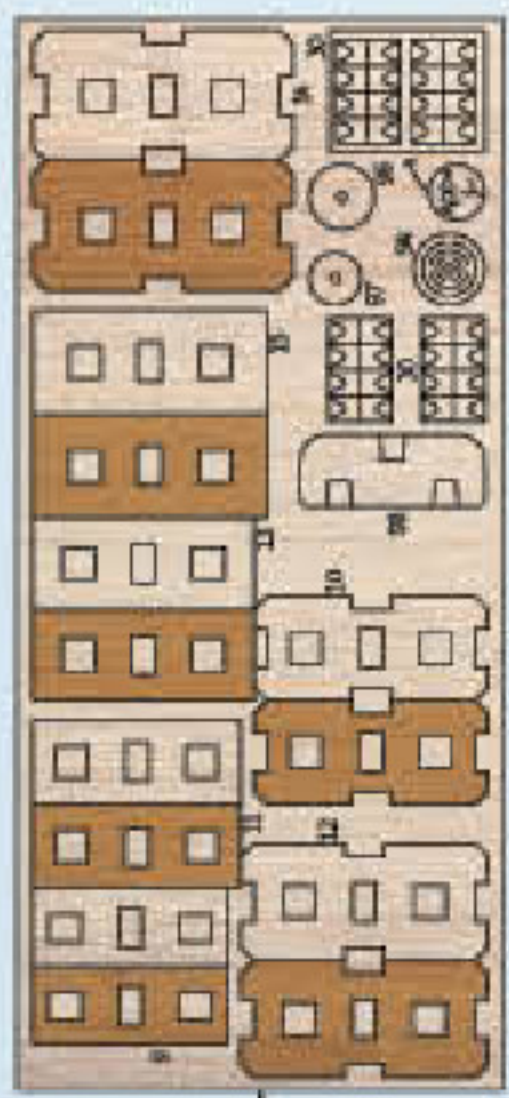

3

4

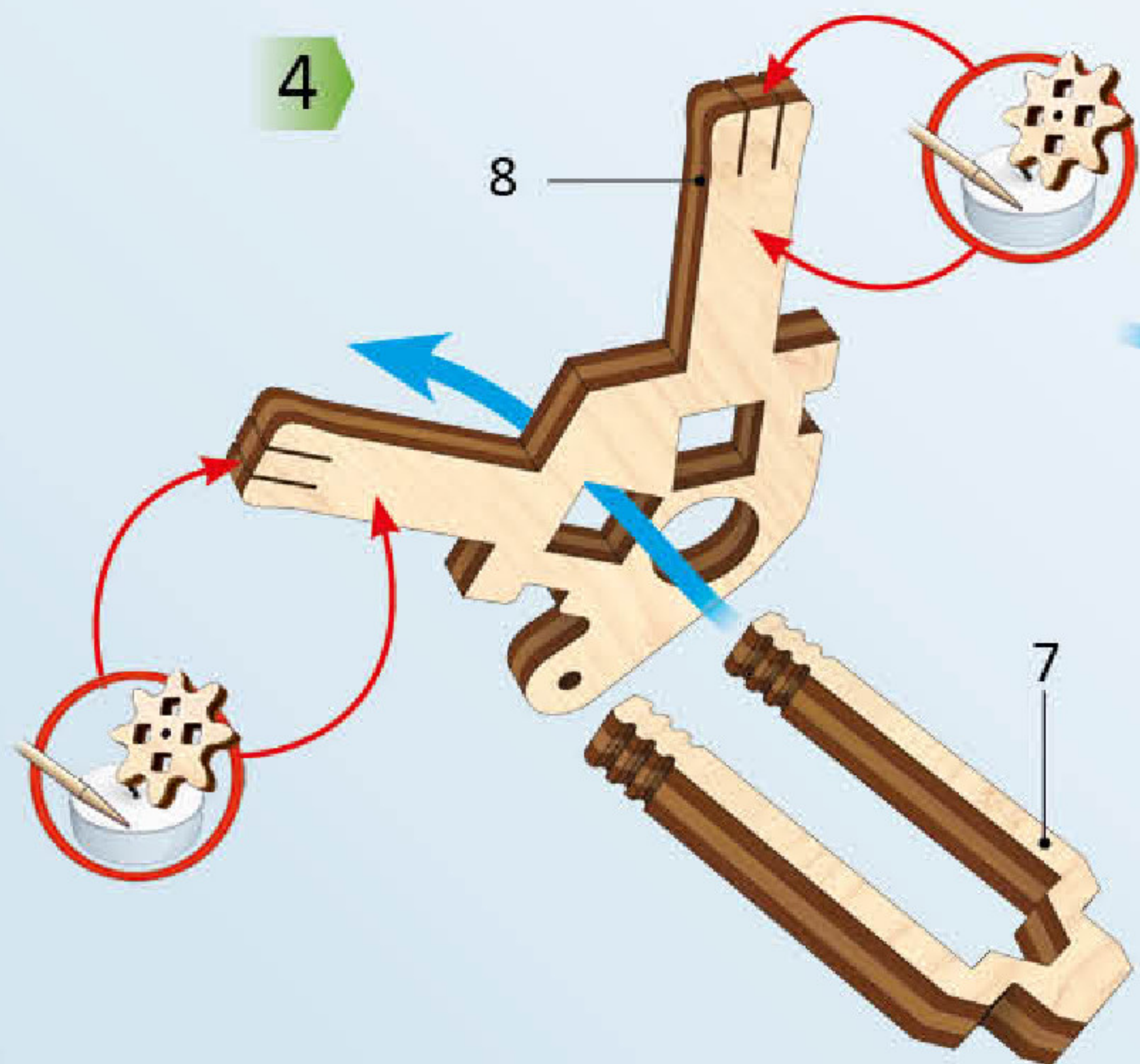

5

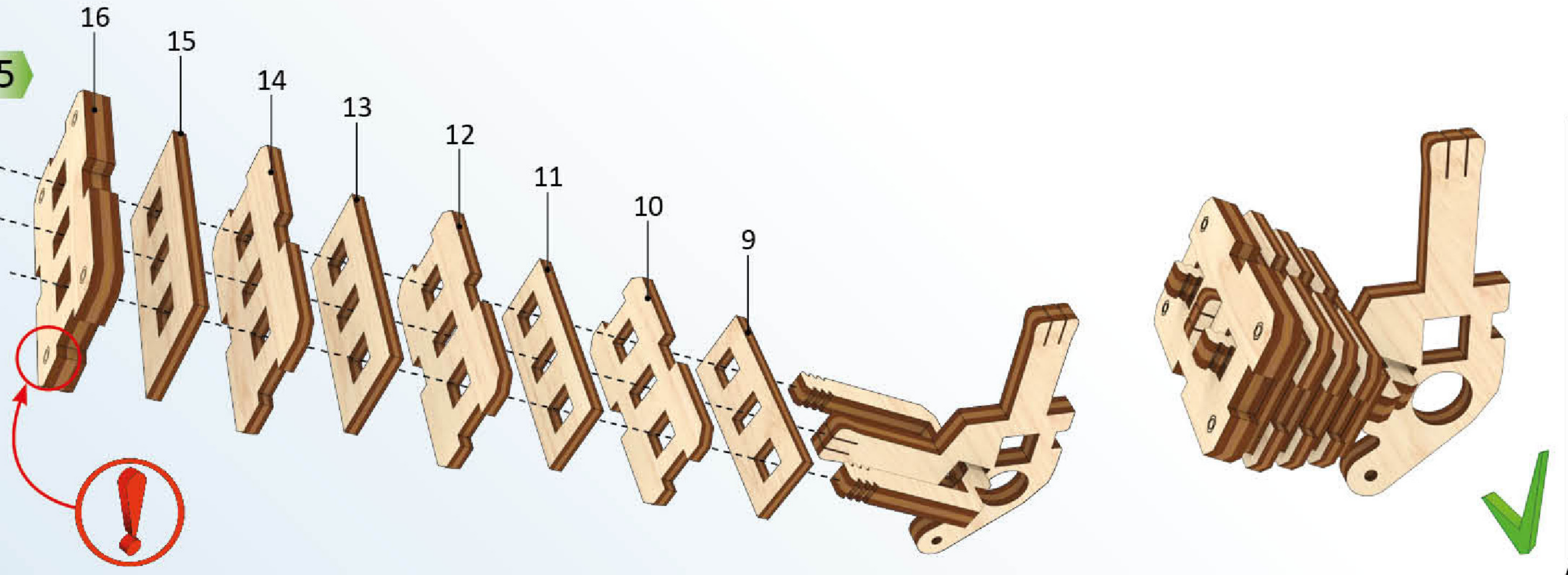

6

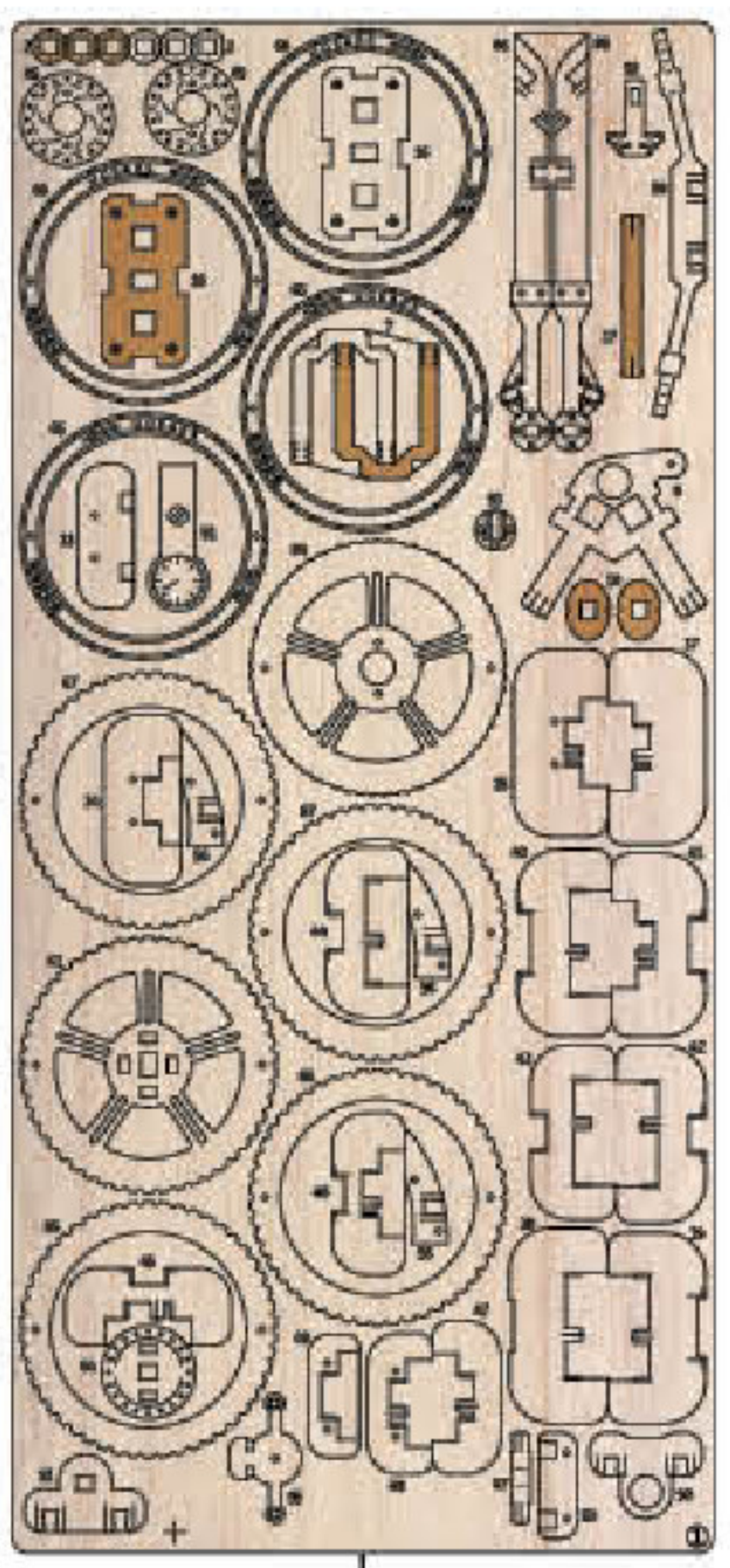

1

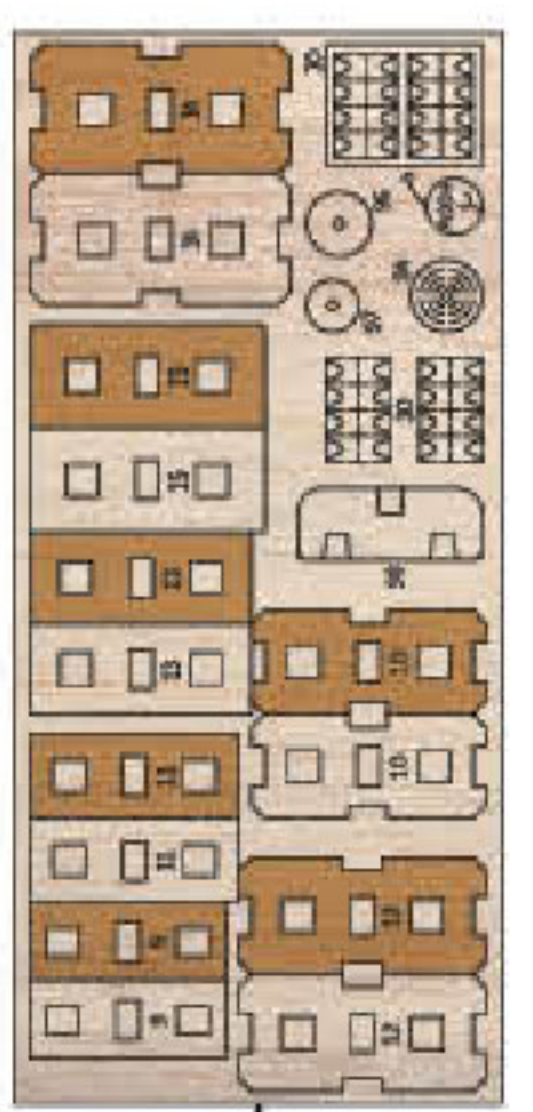
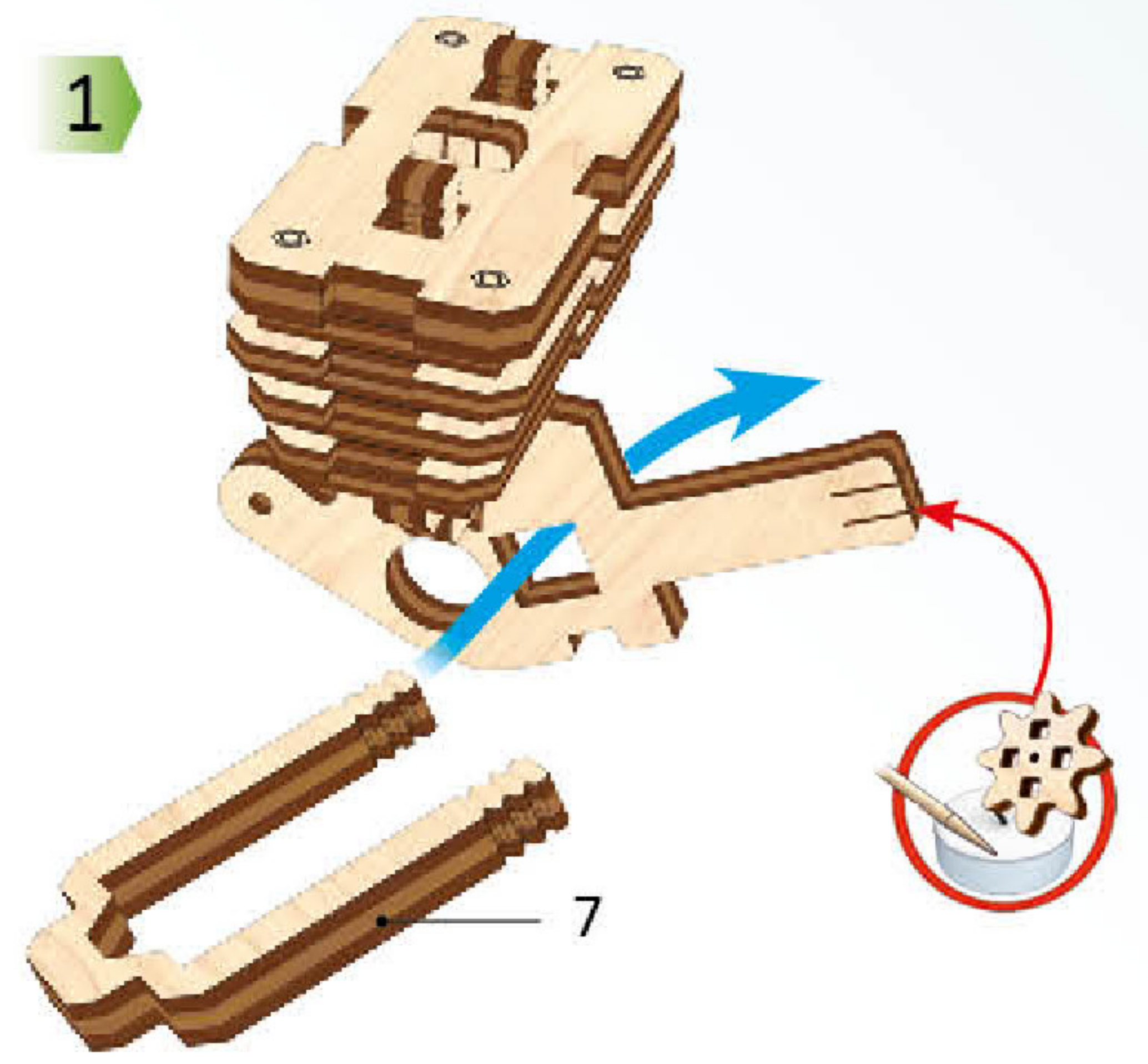

3

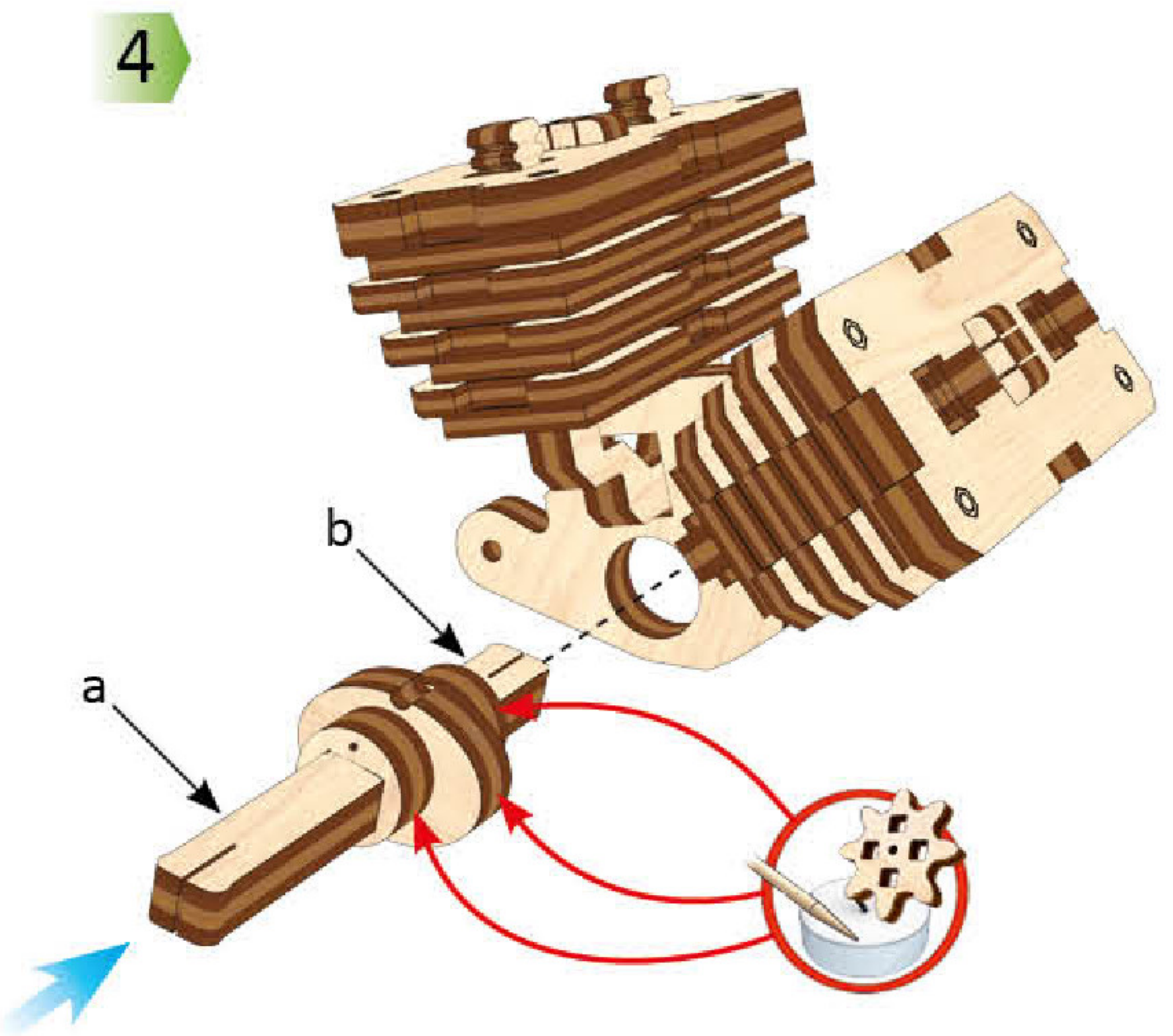

2

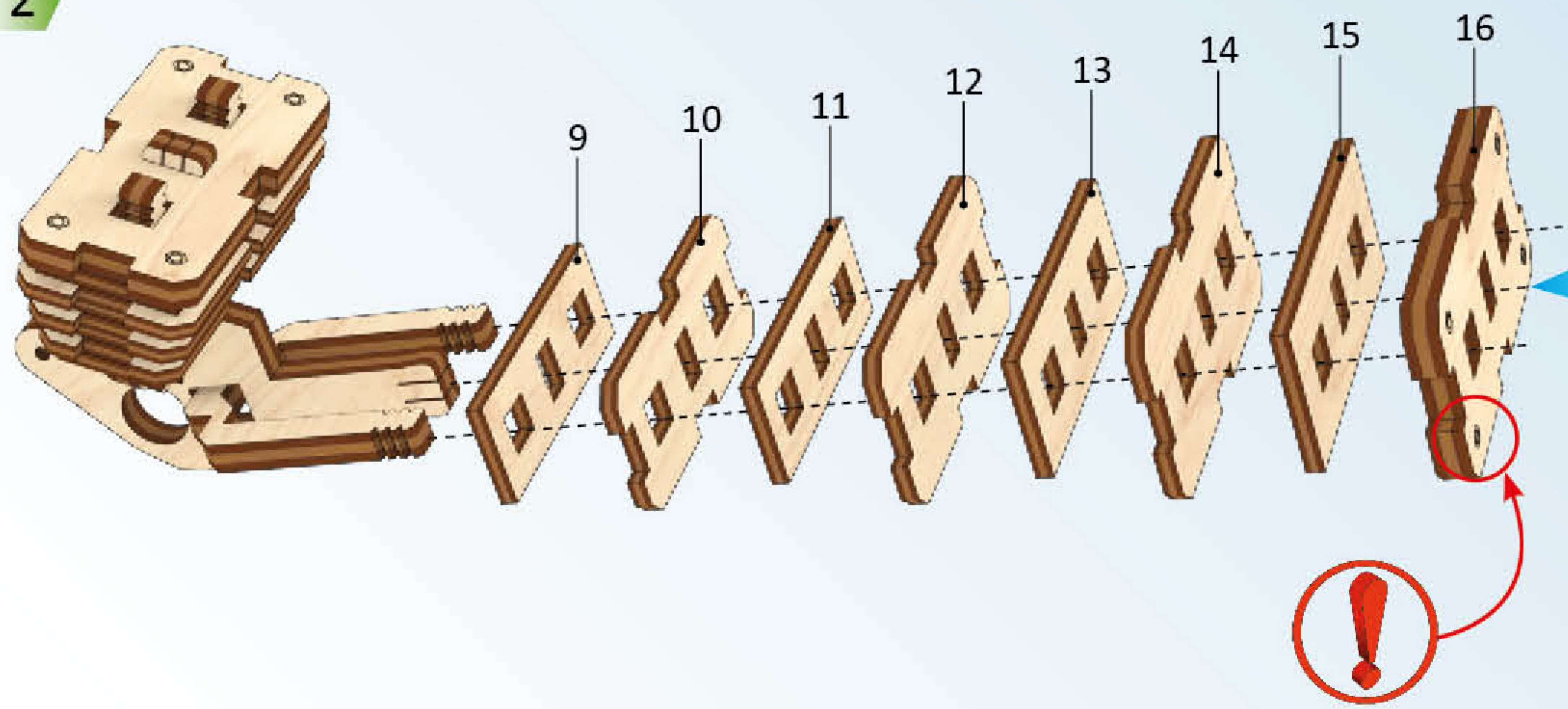

3

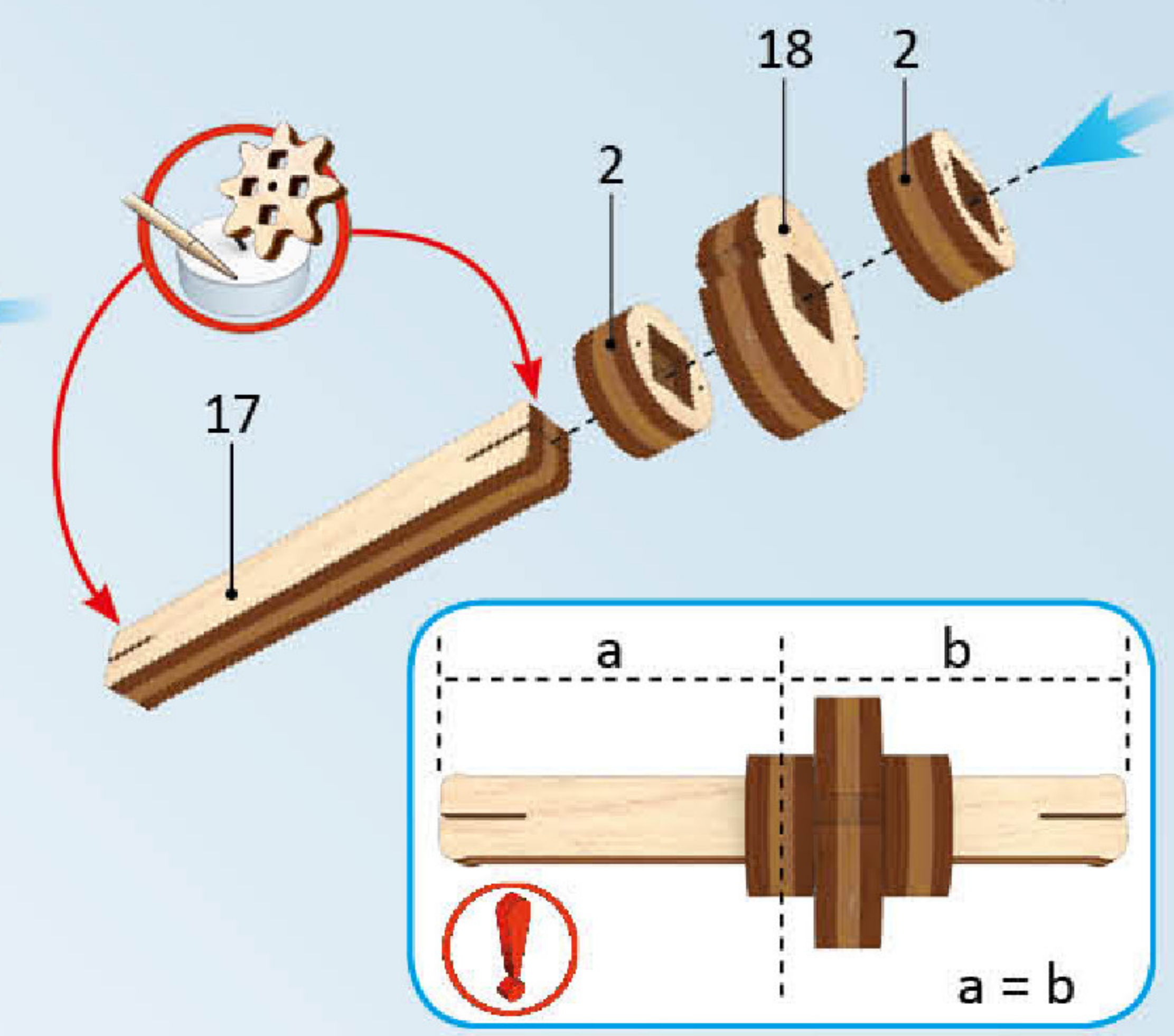

5

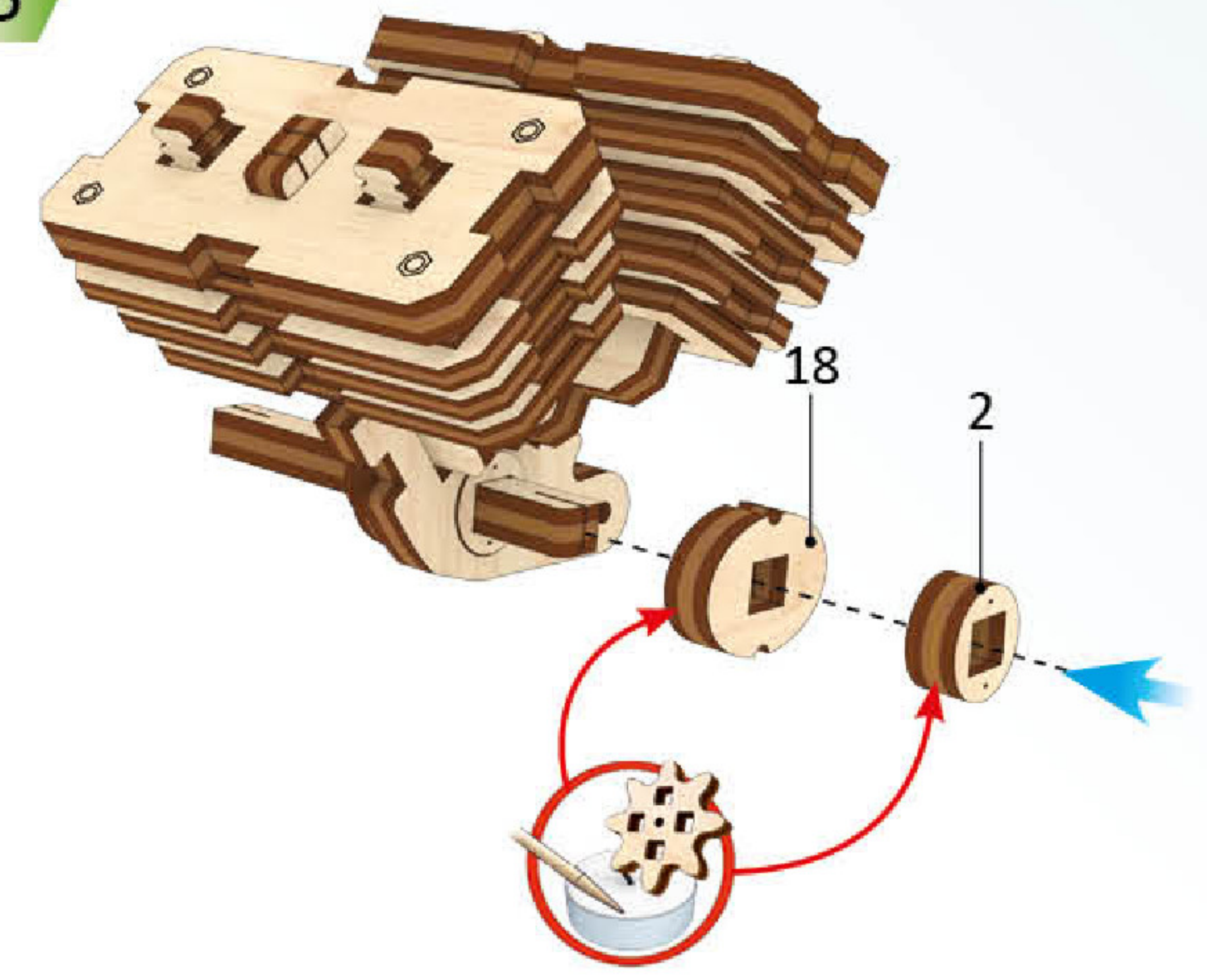

6

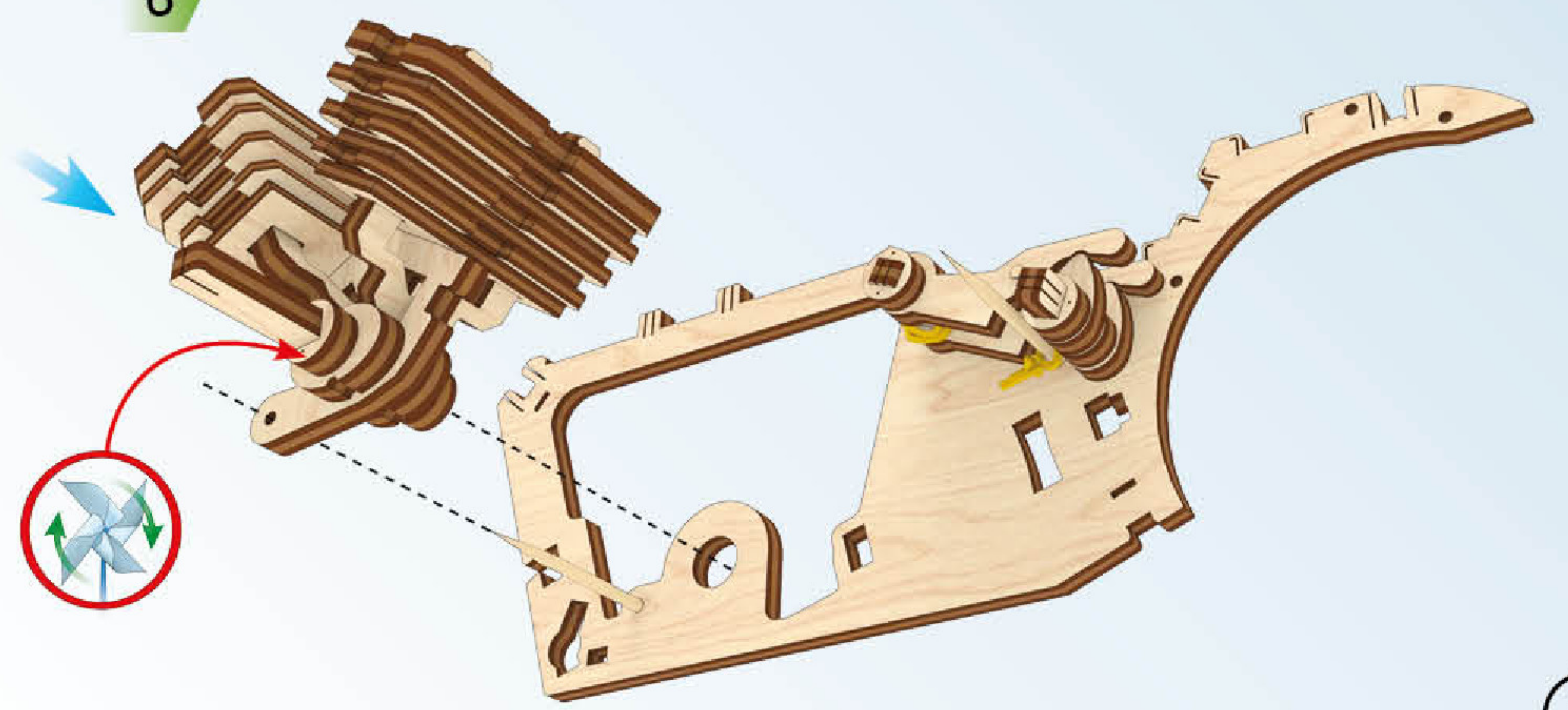

7

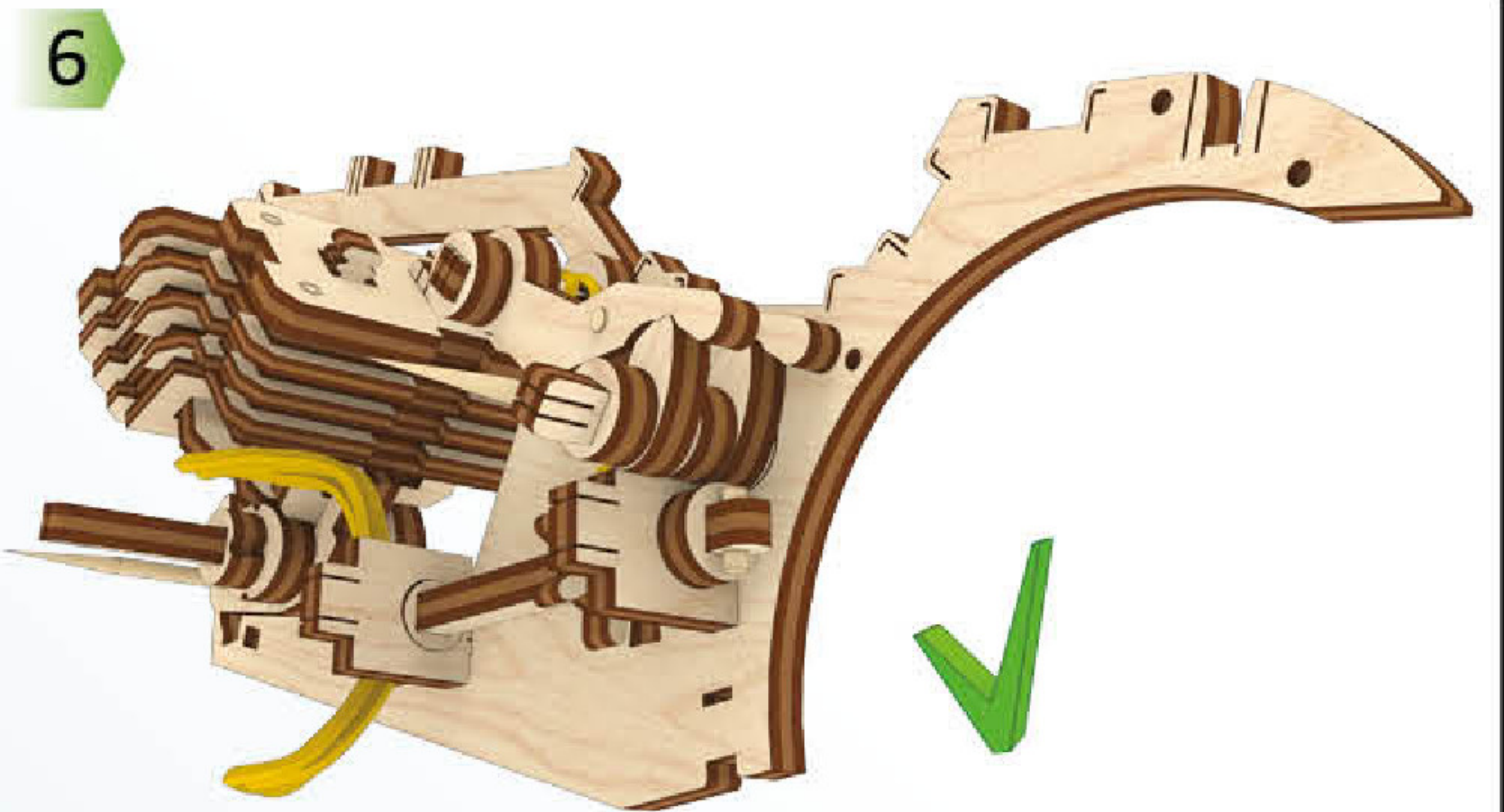
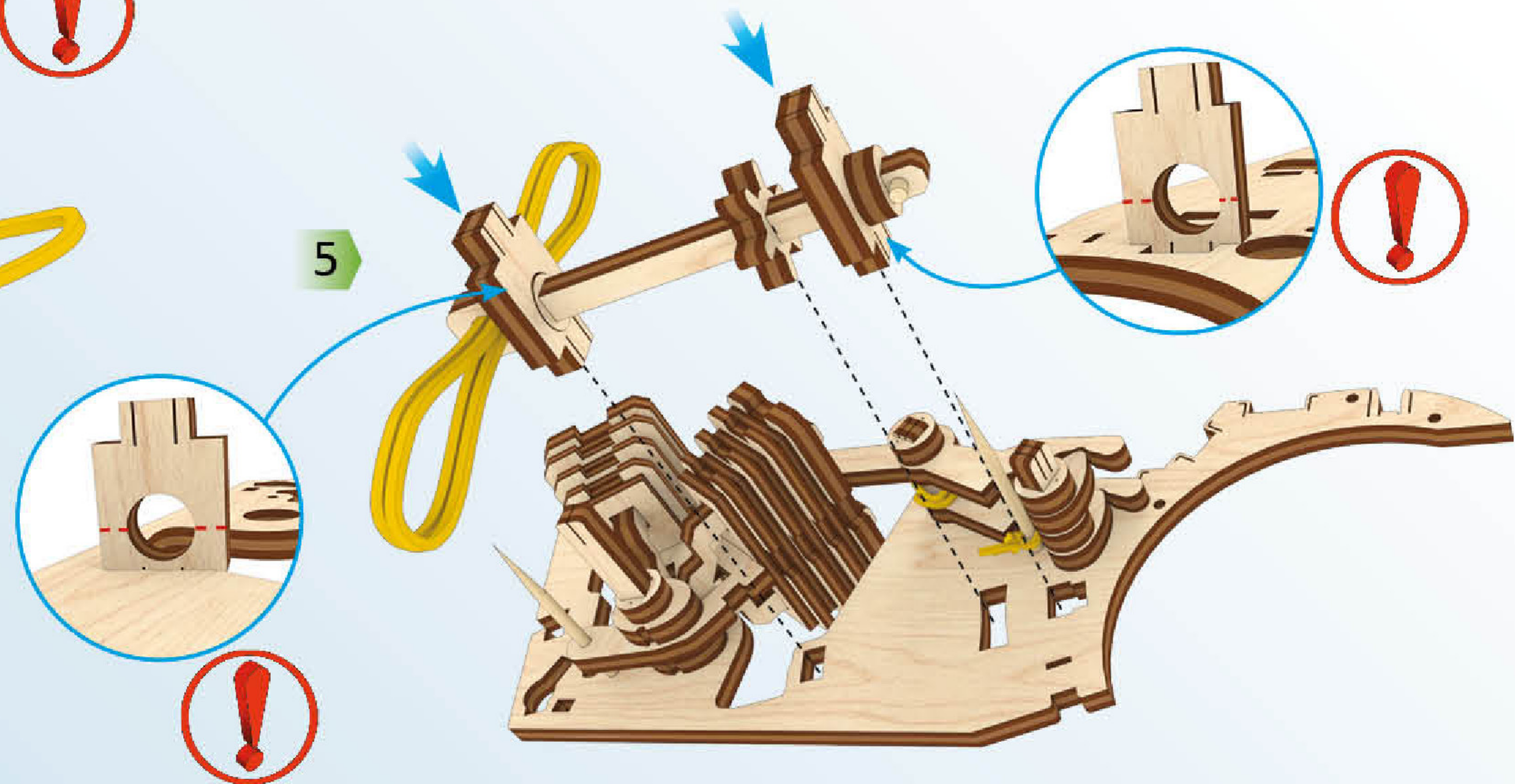
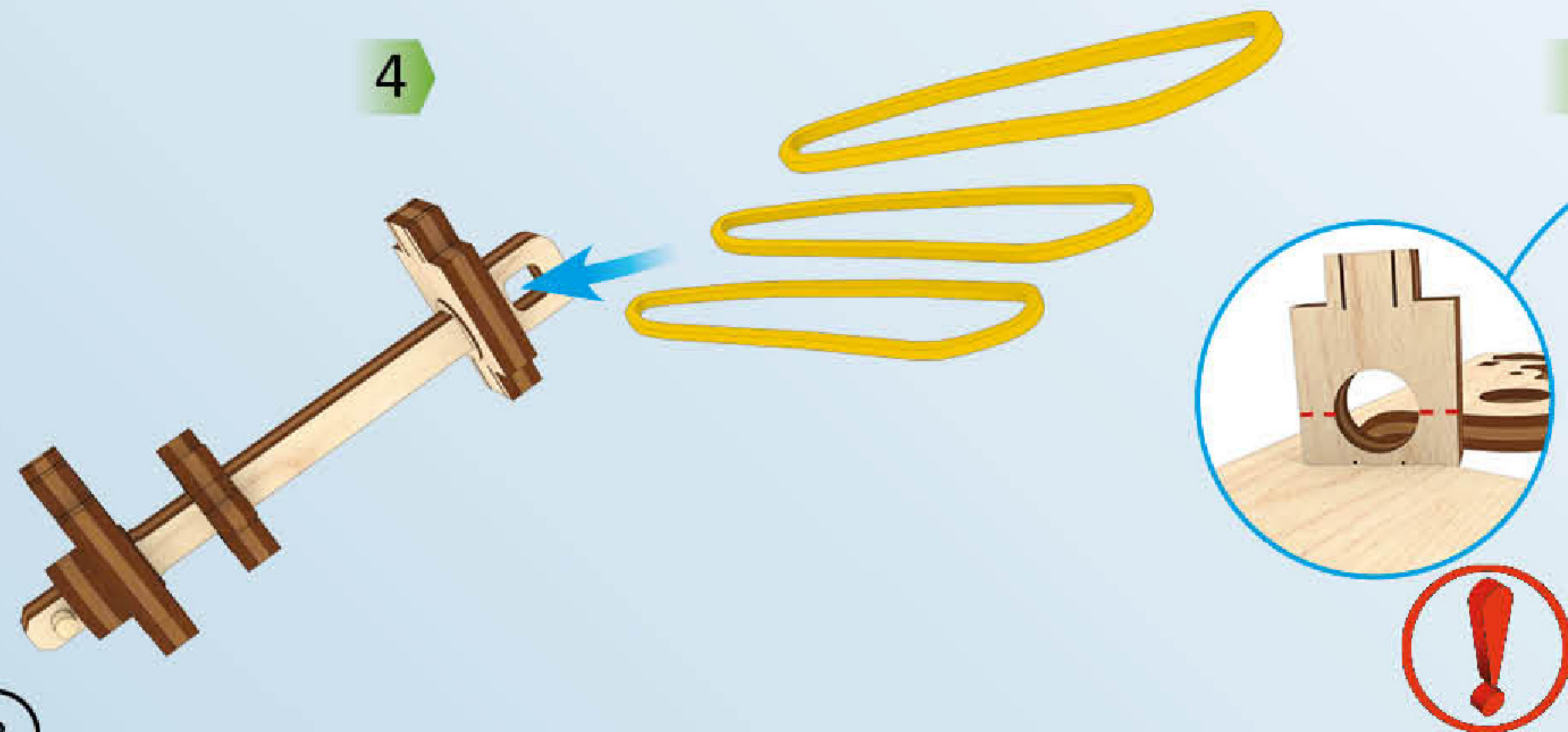
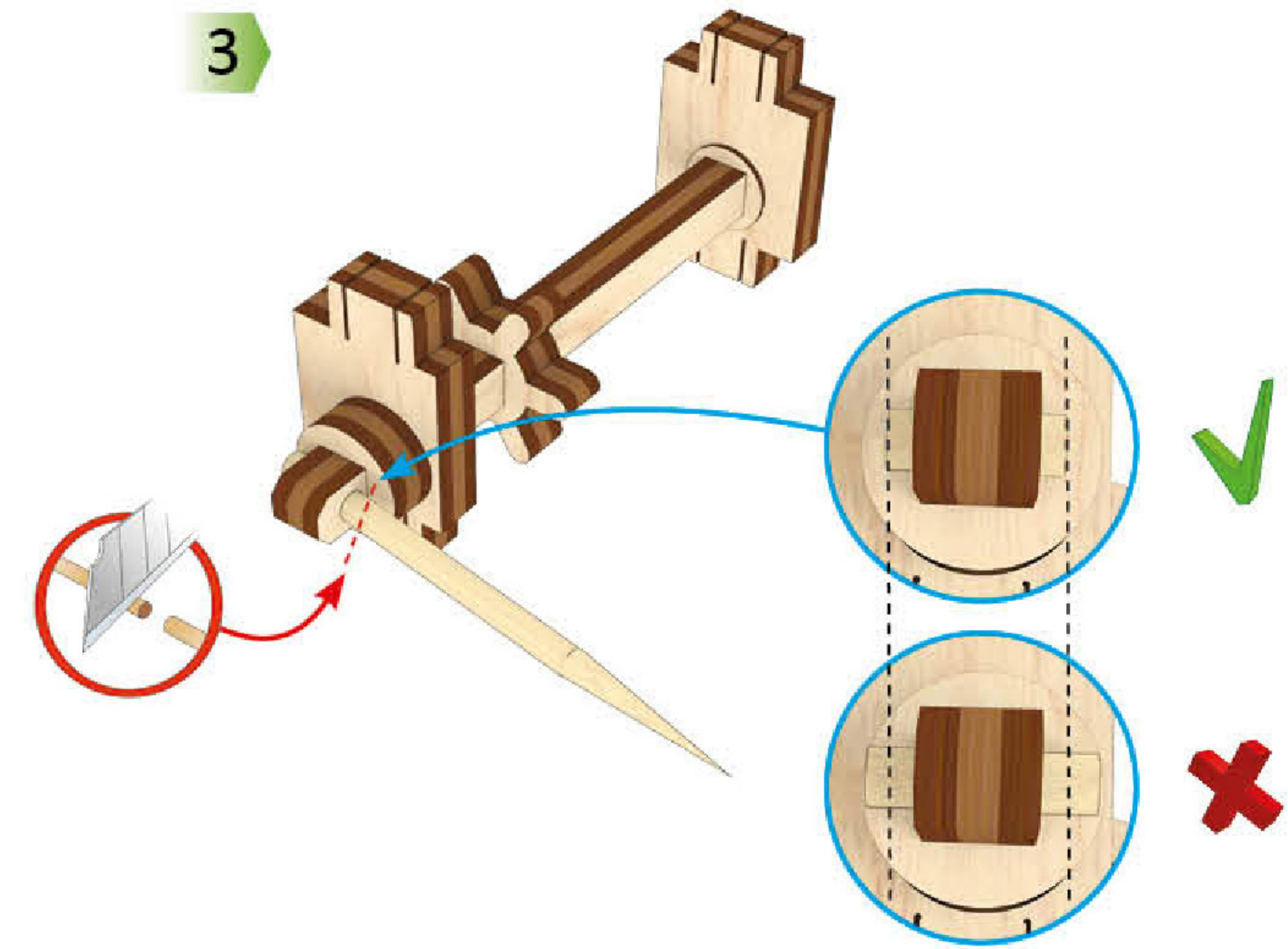
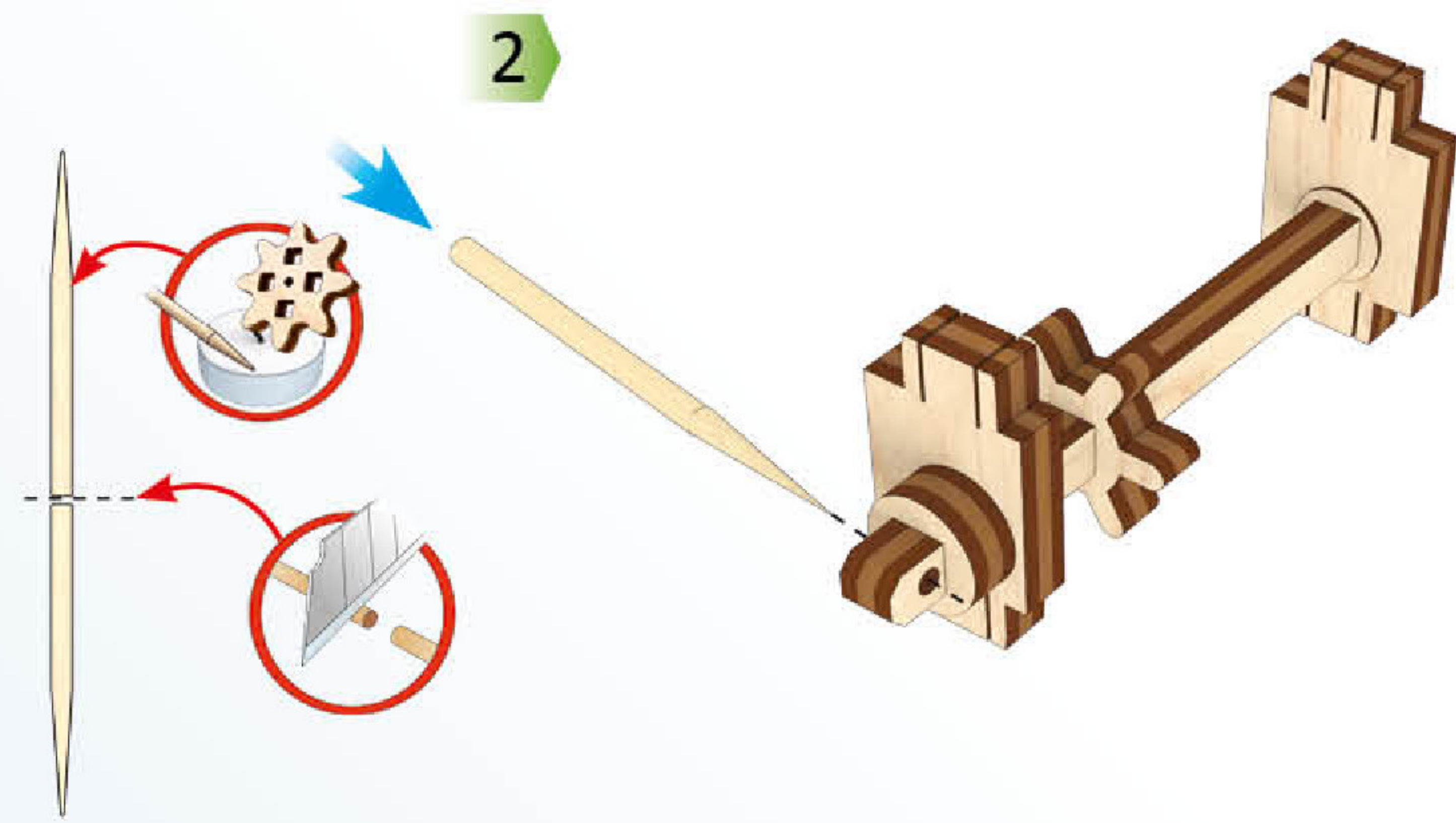
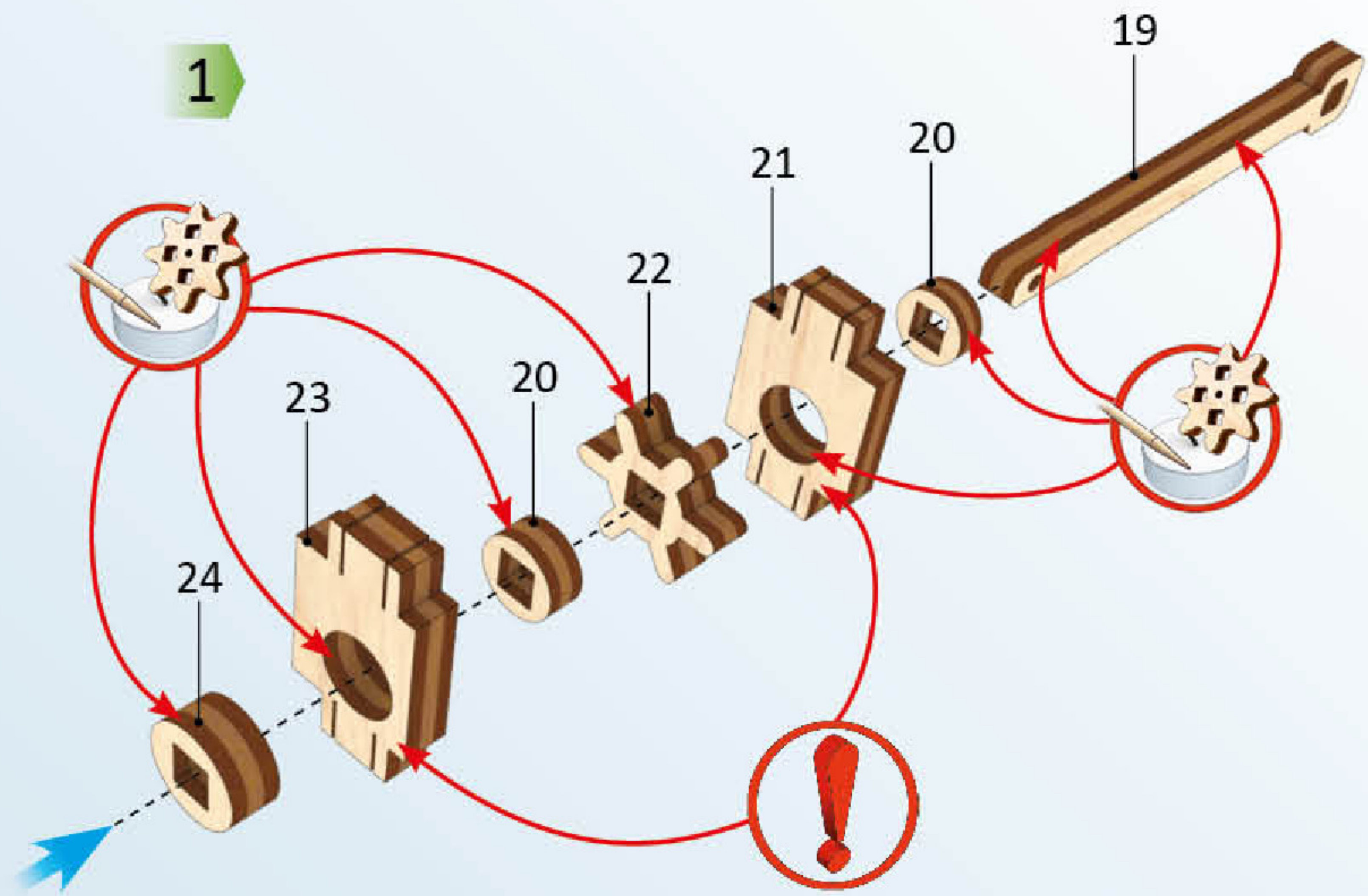
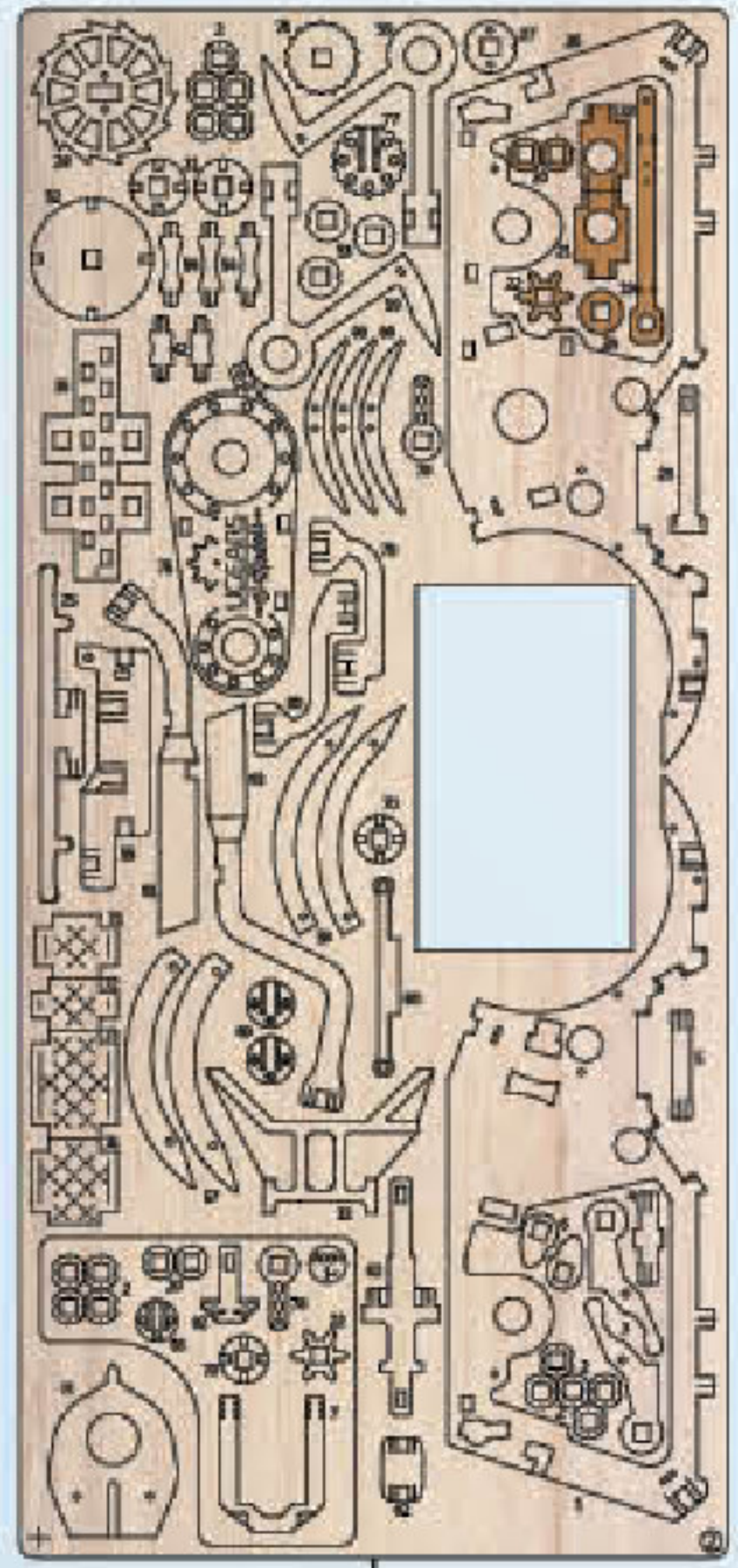

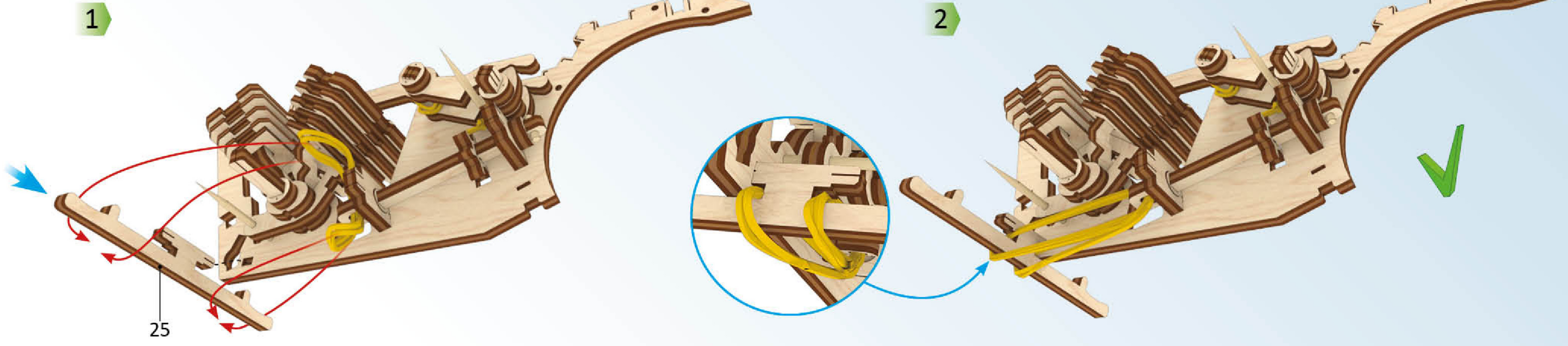
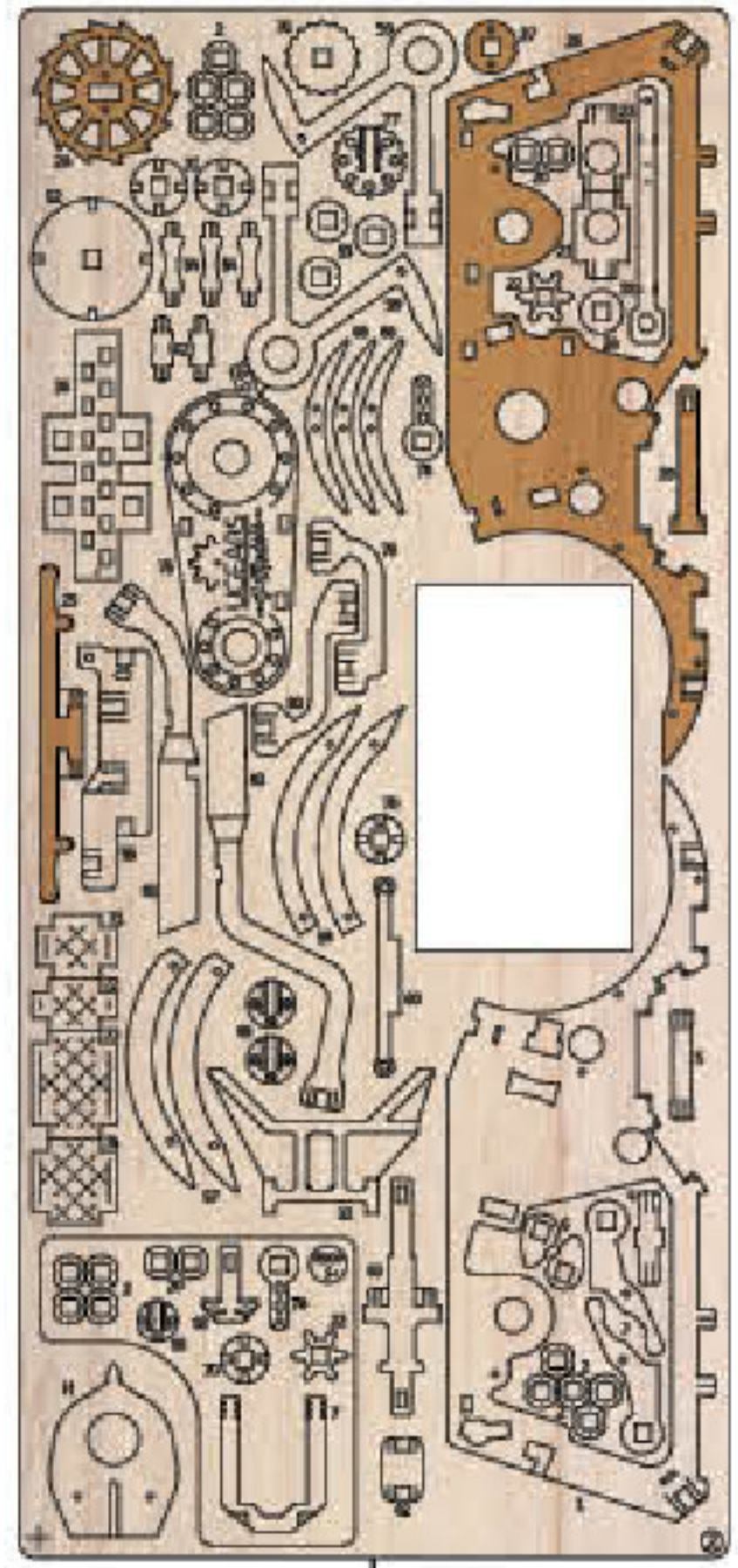

2

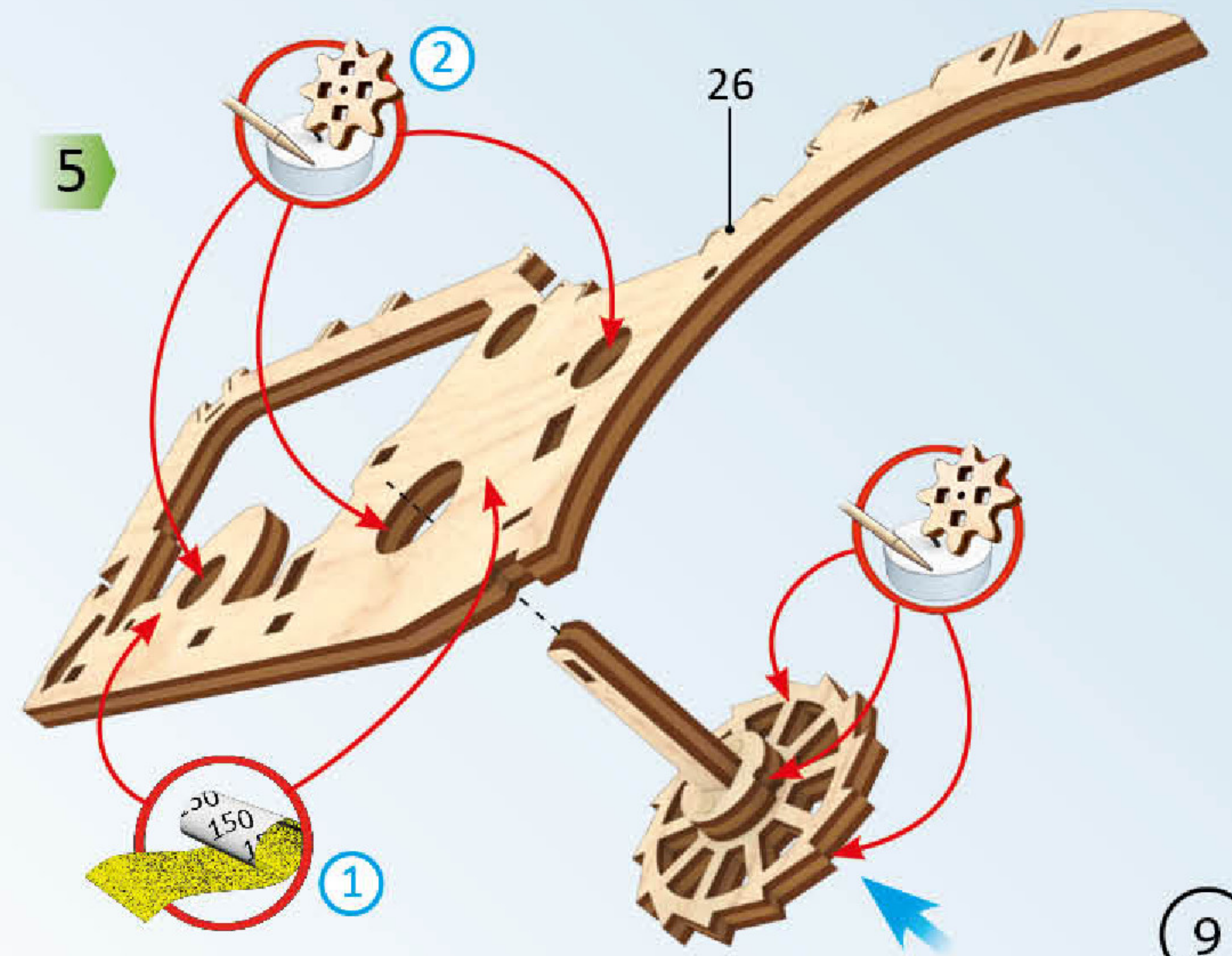
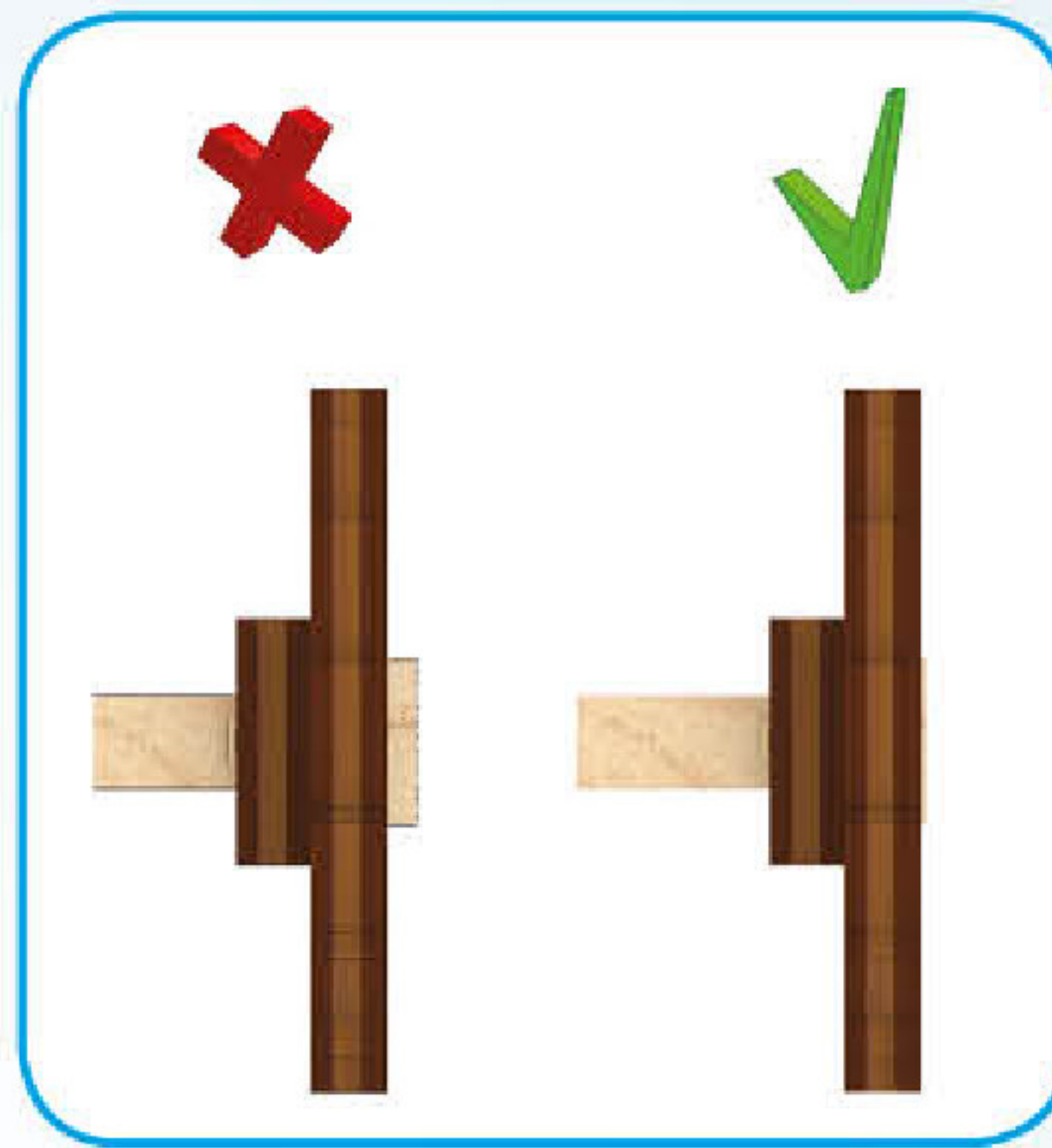
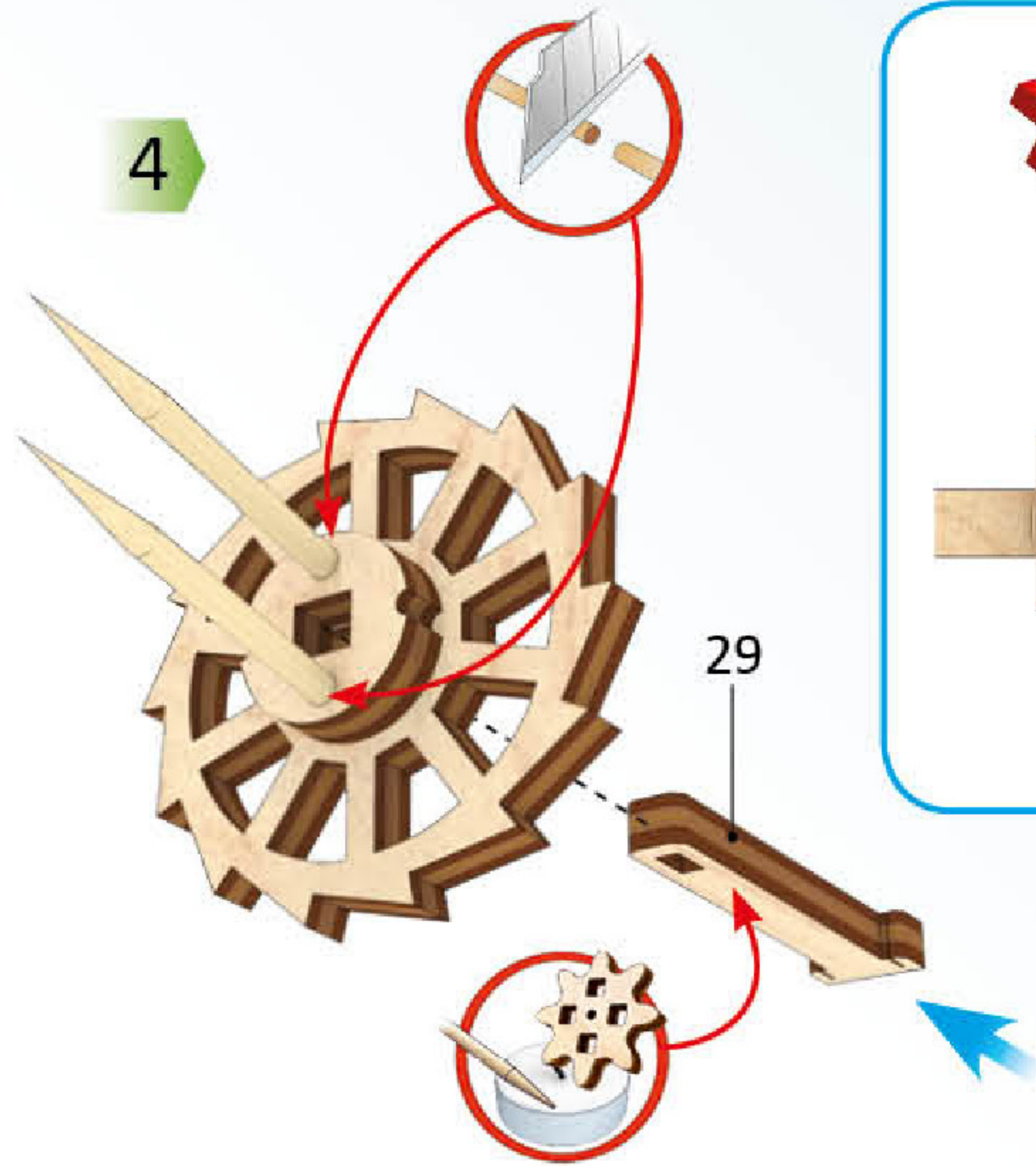
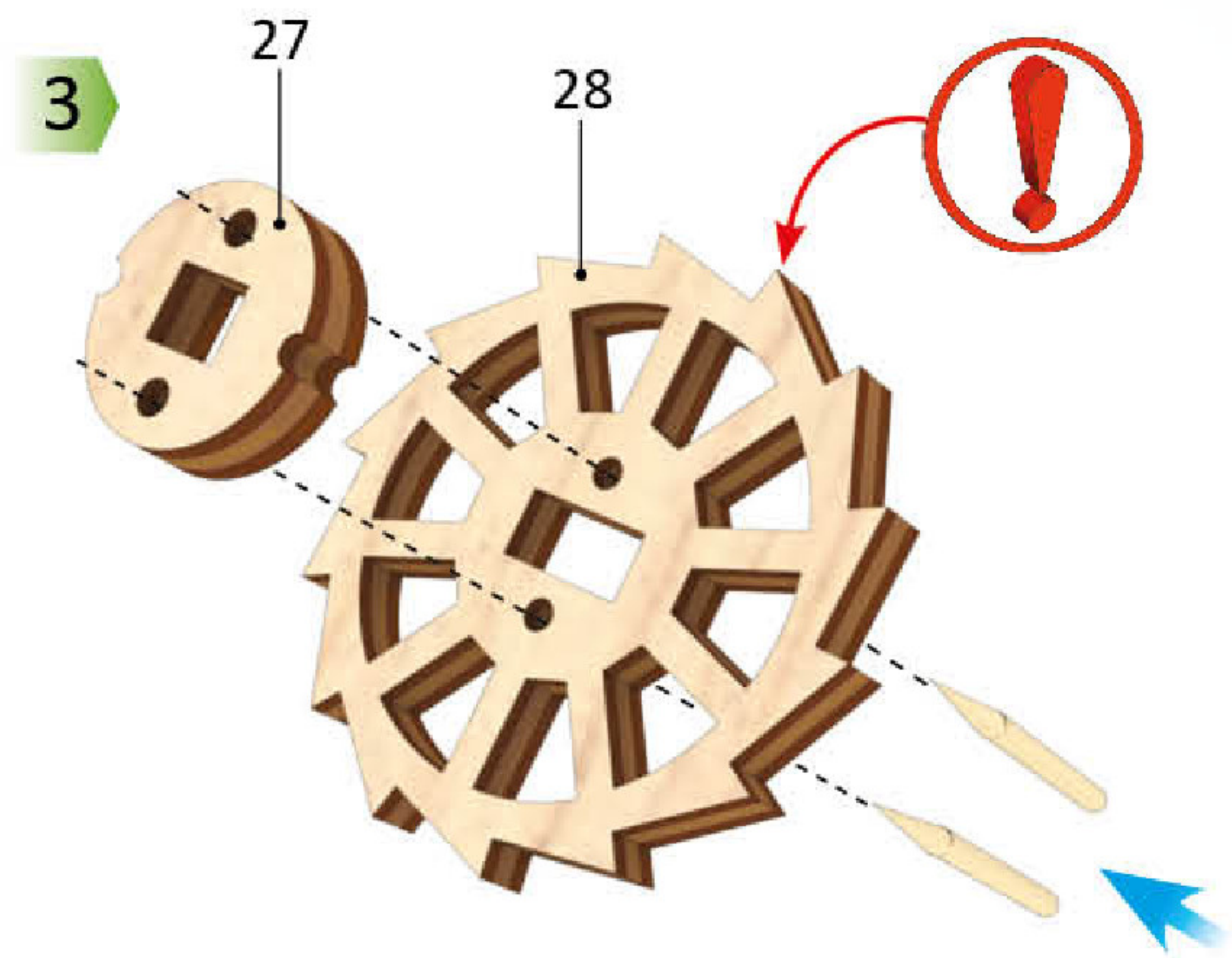
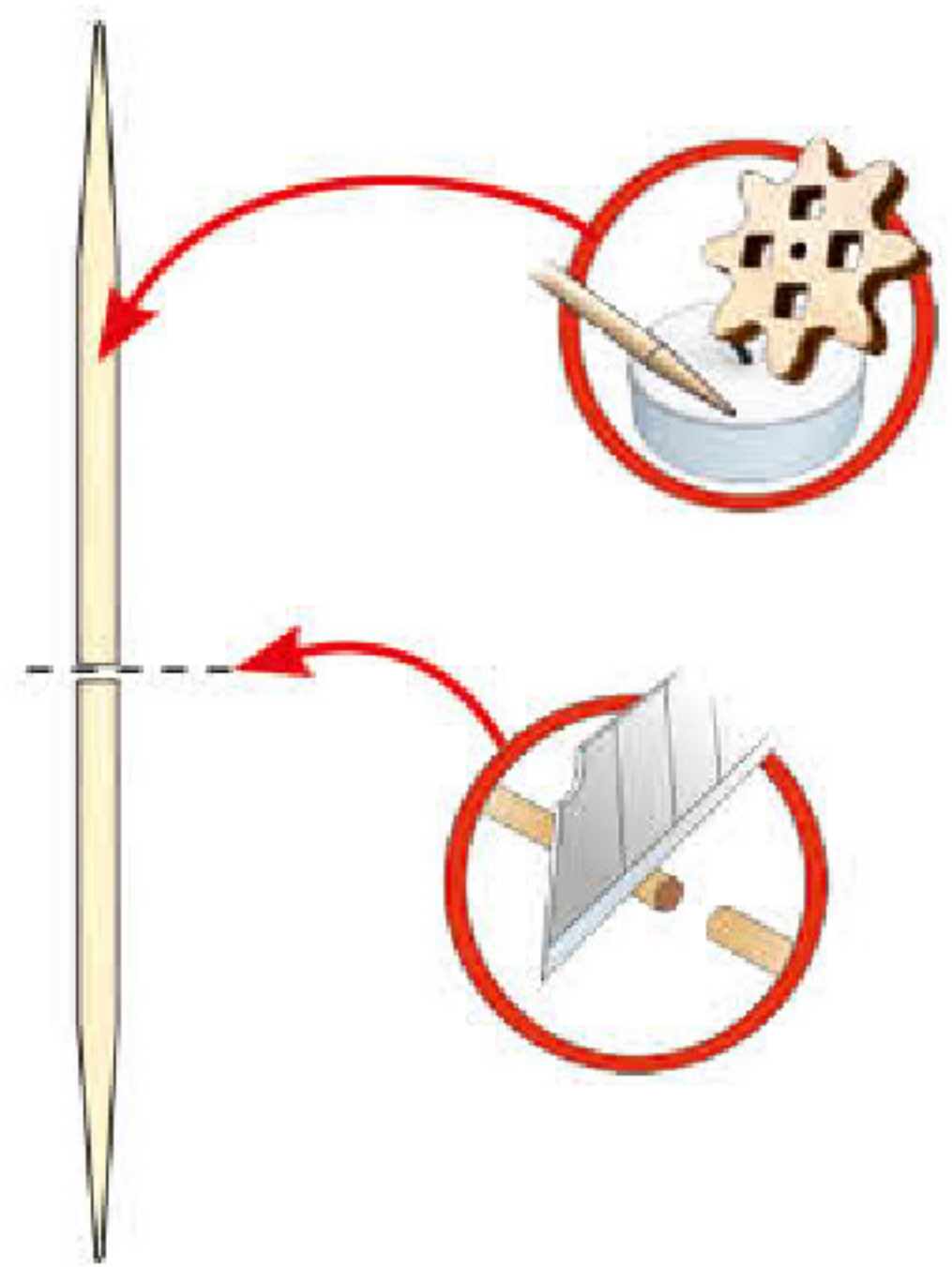

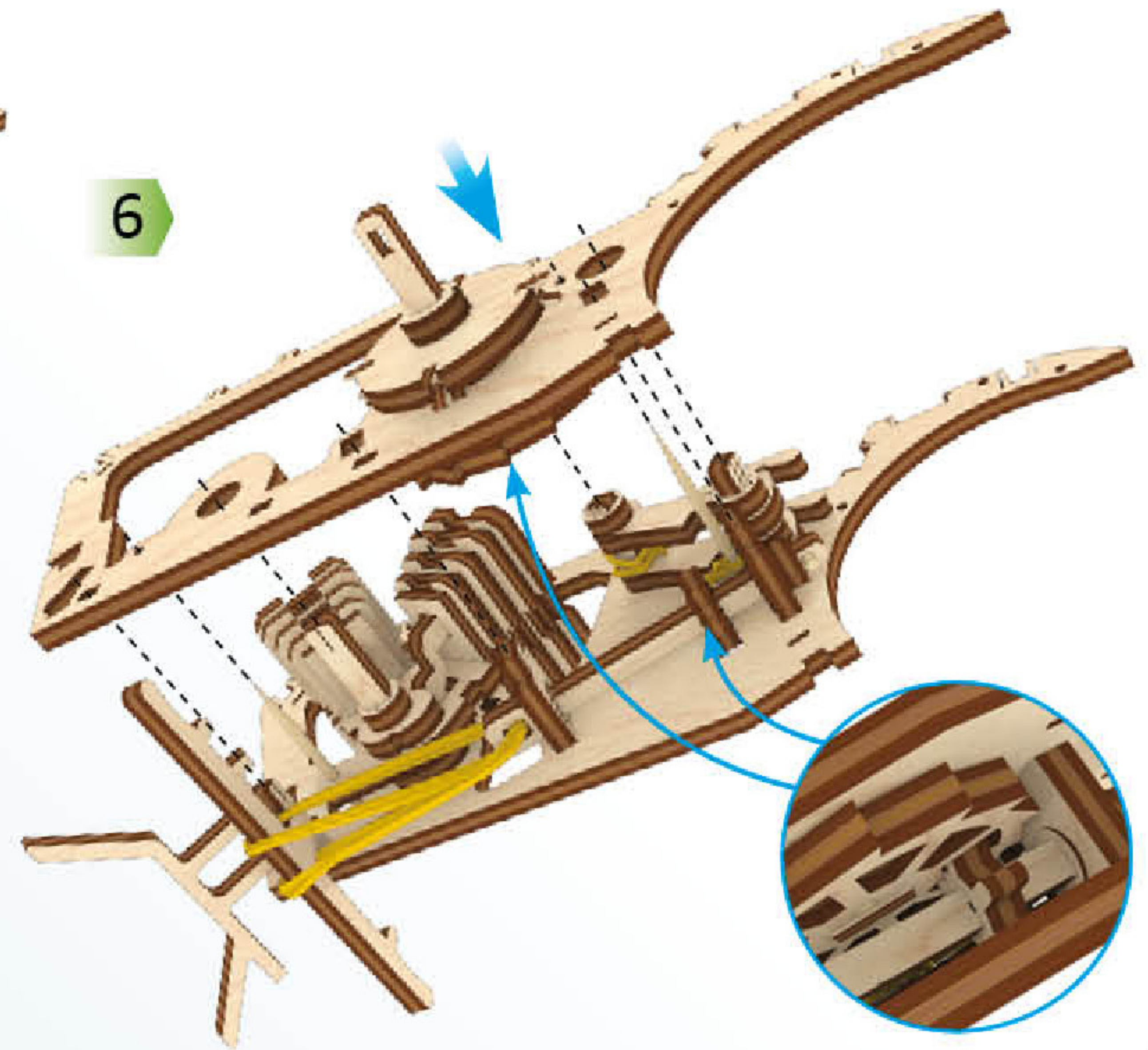
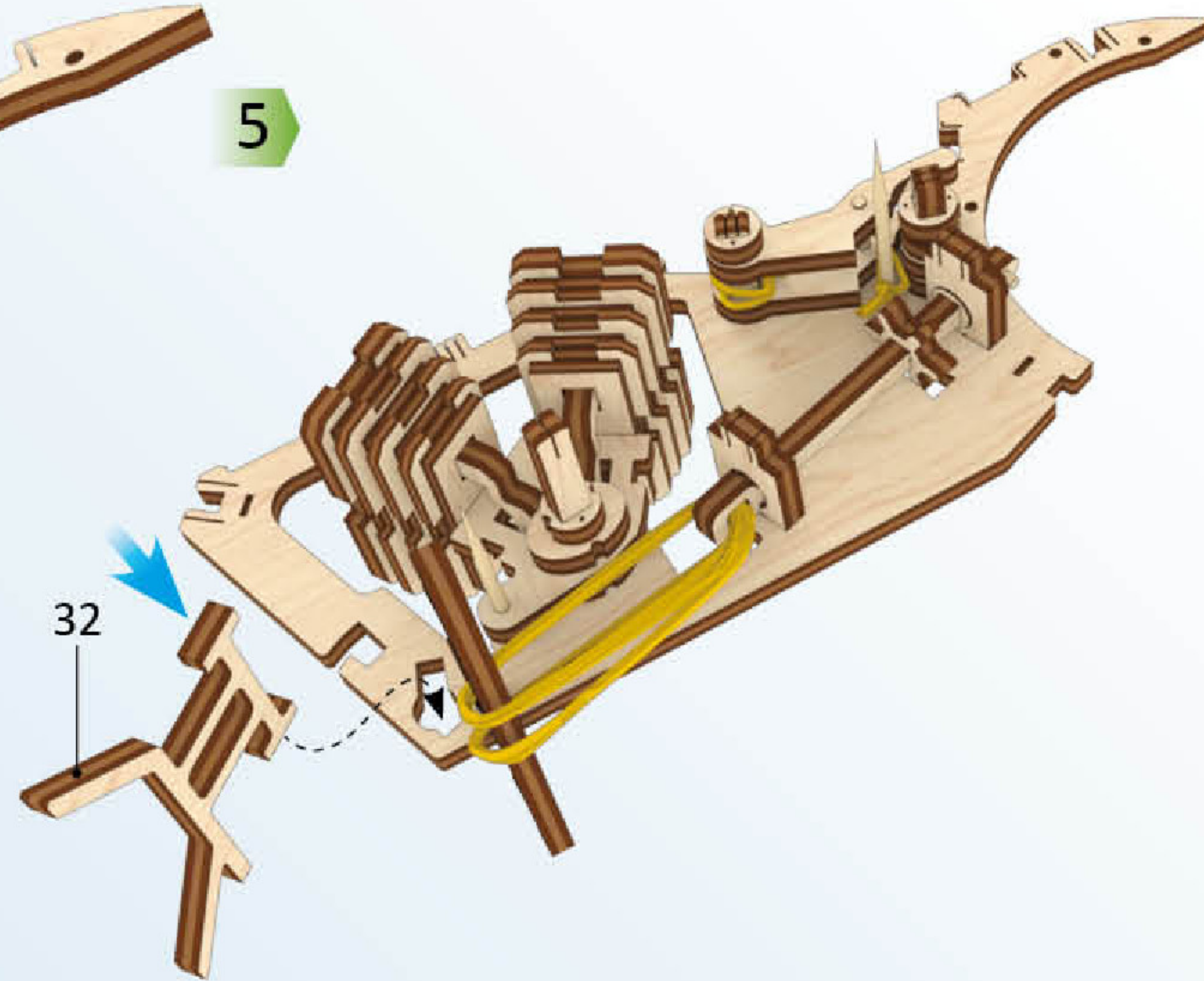
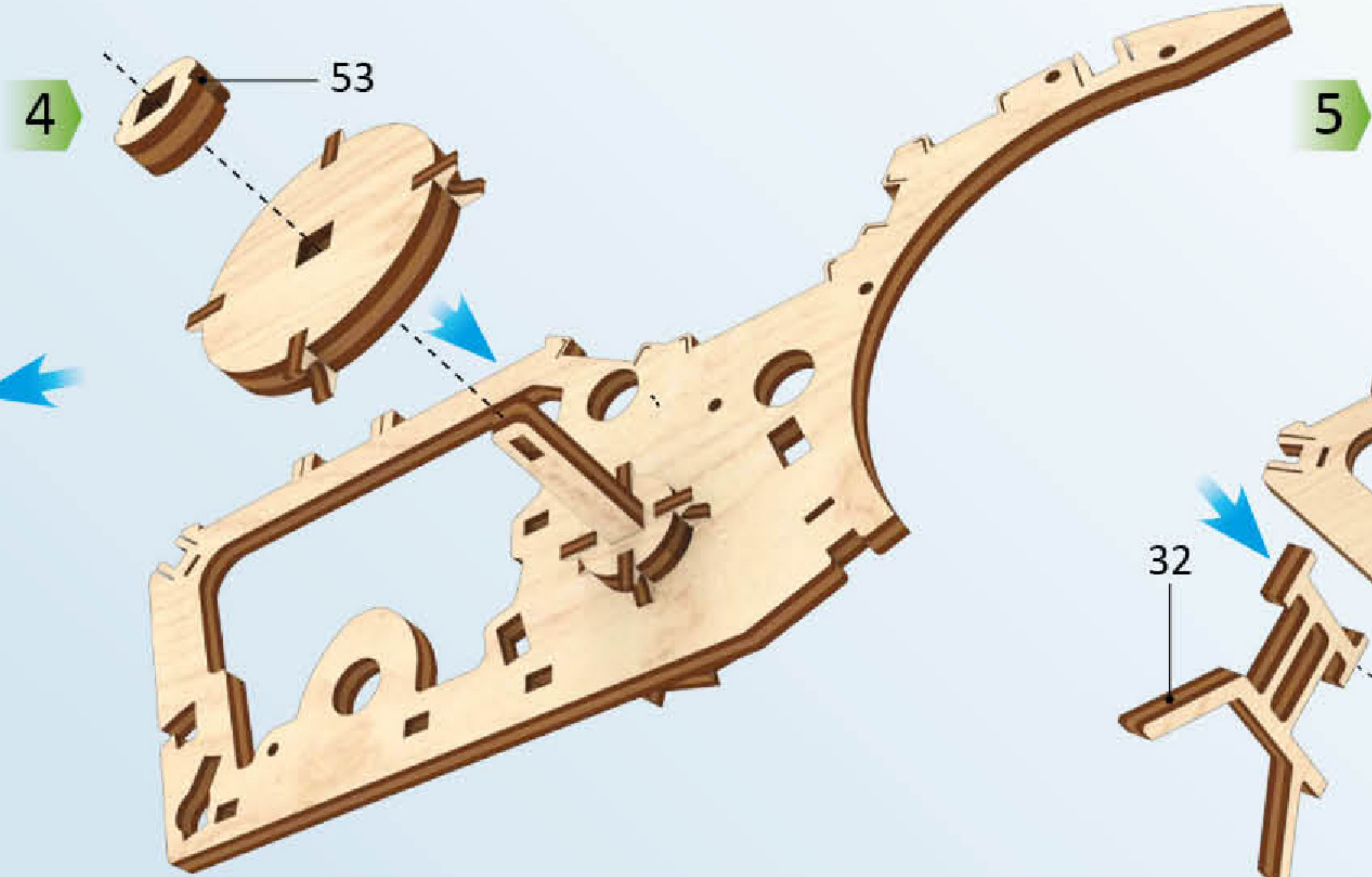
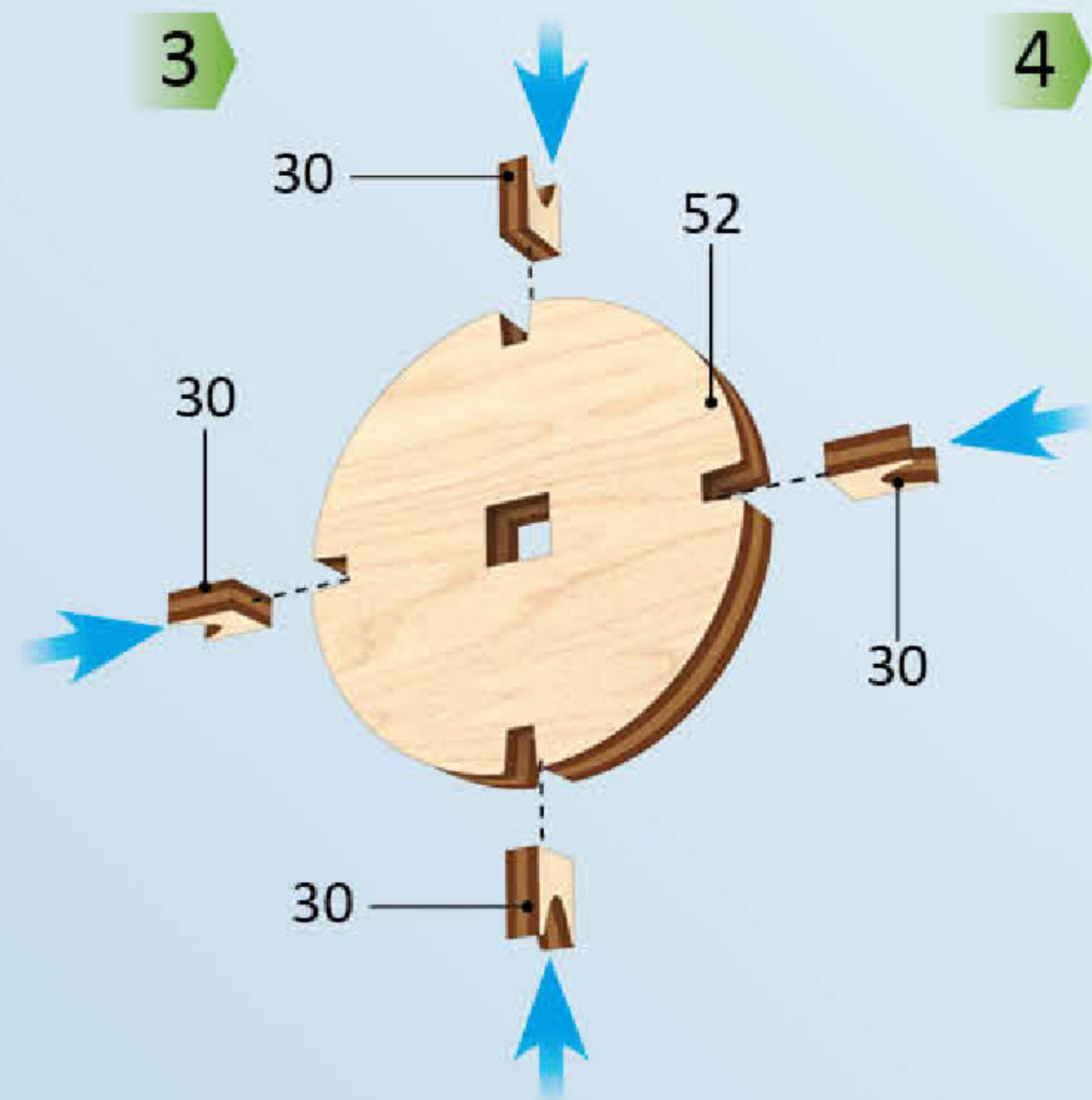
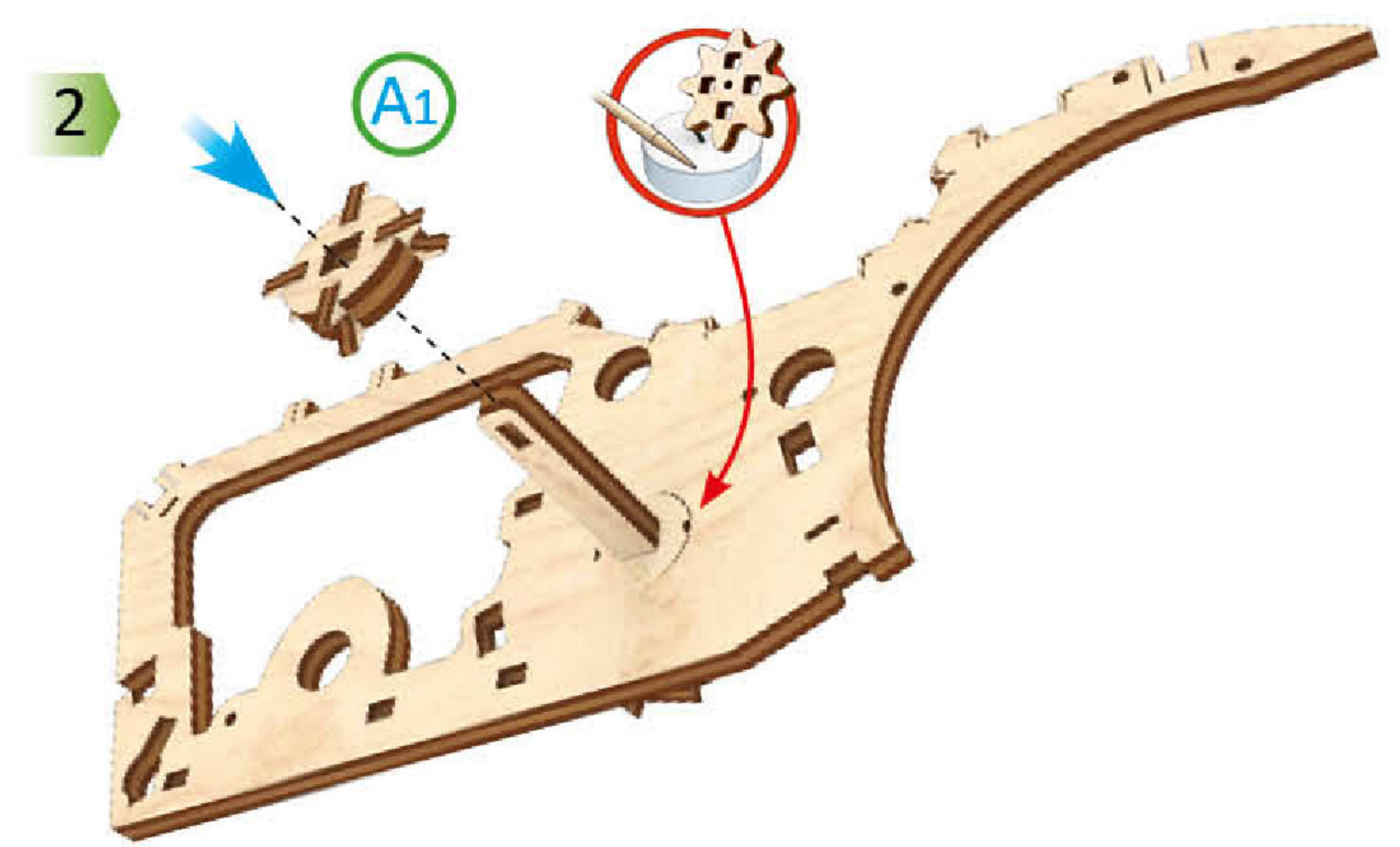
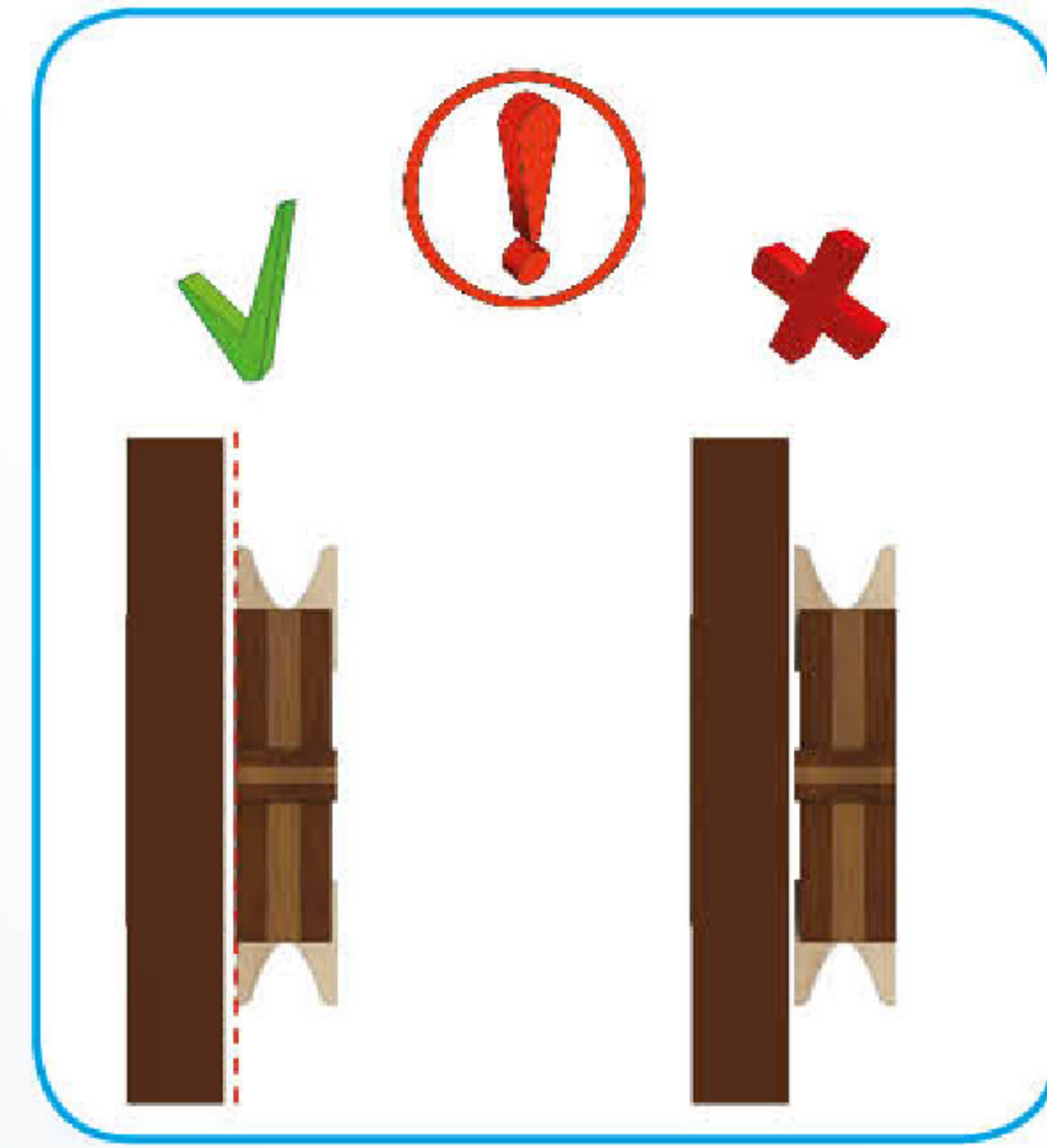
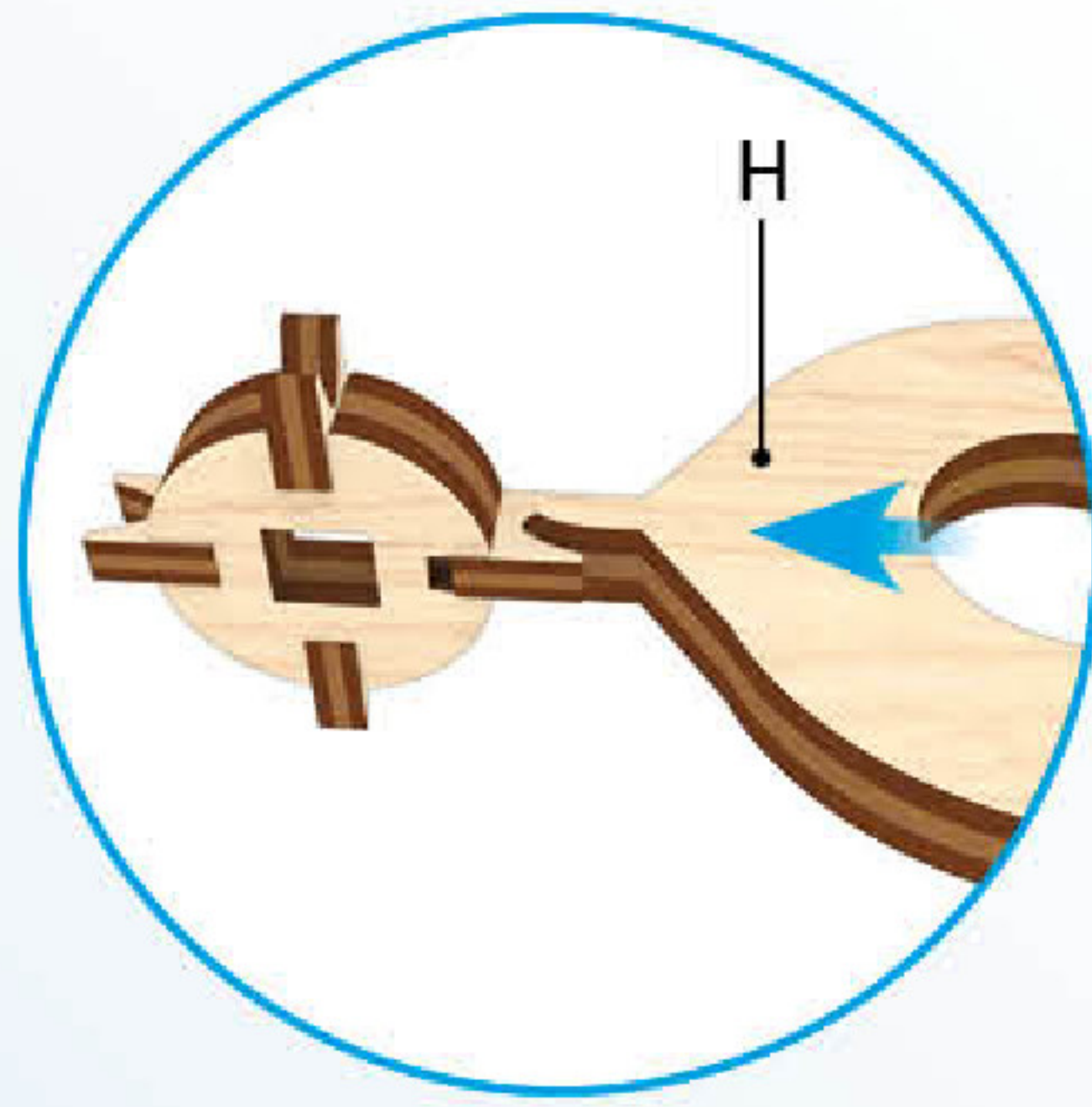
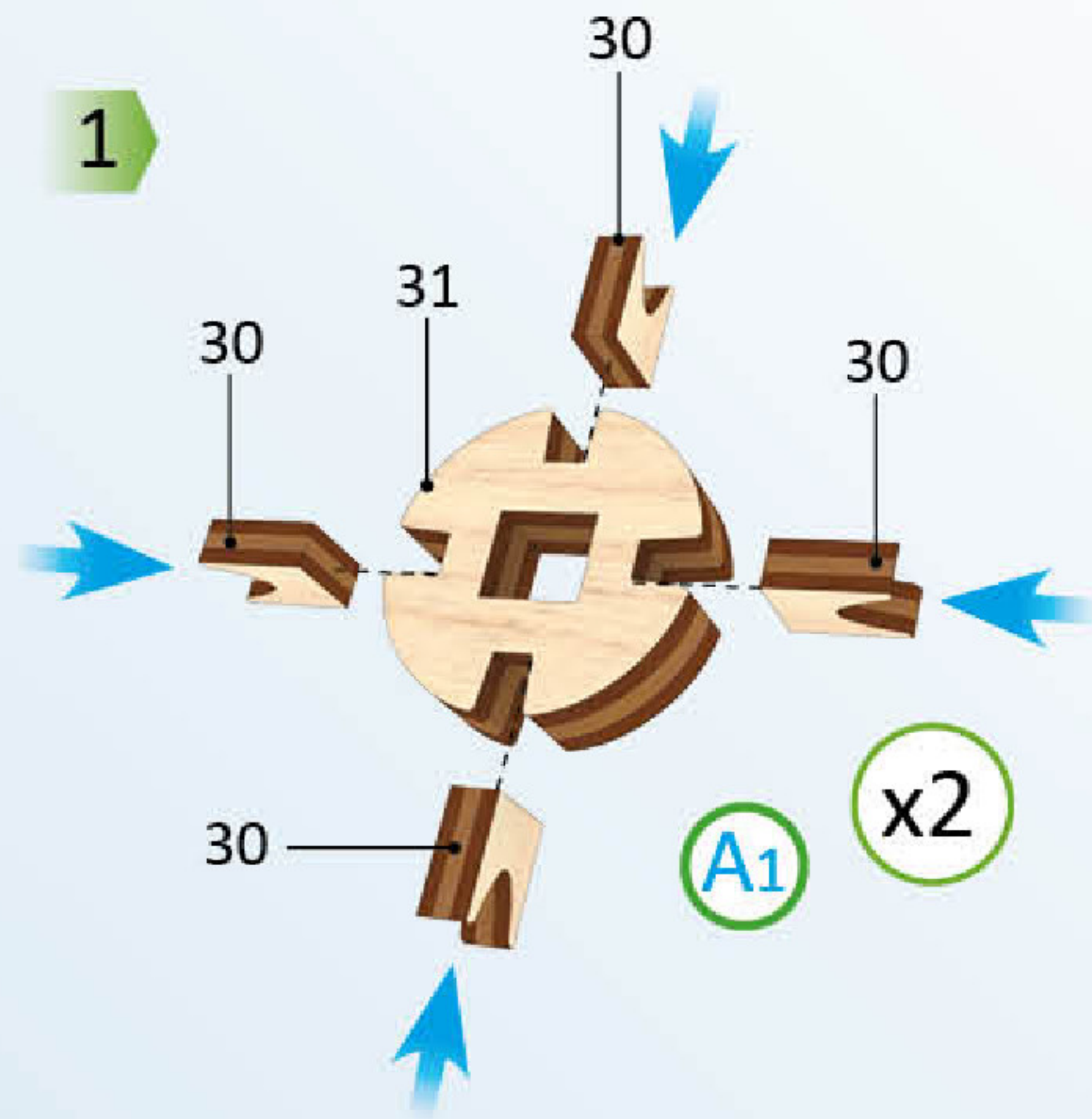
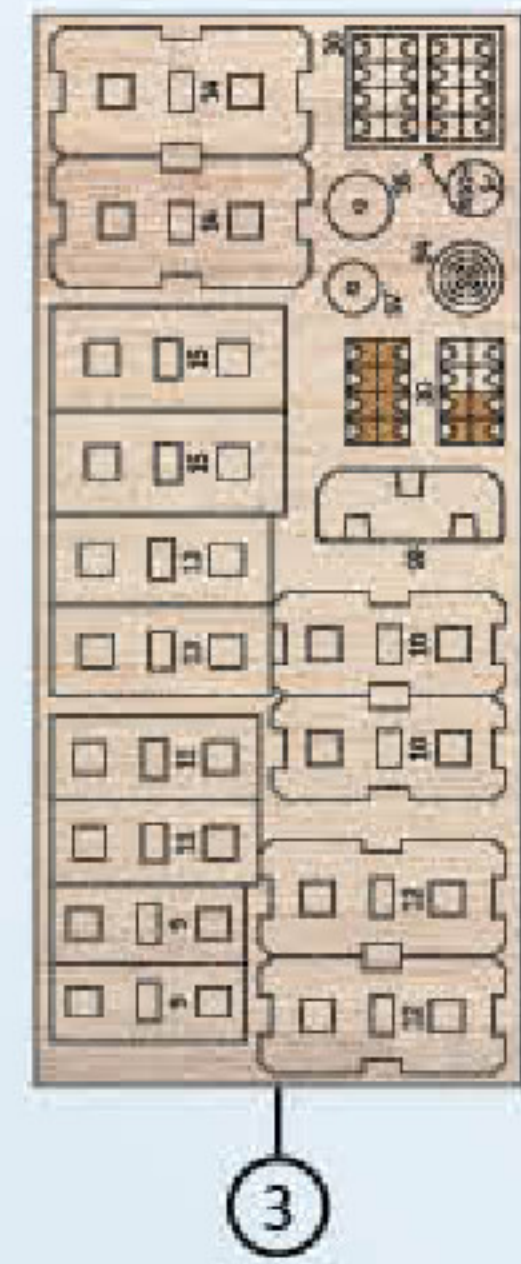
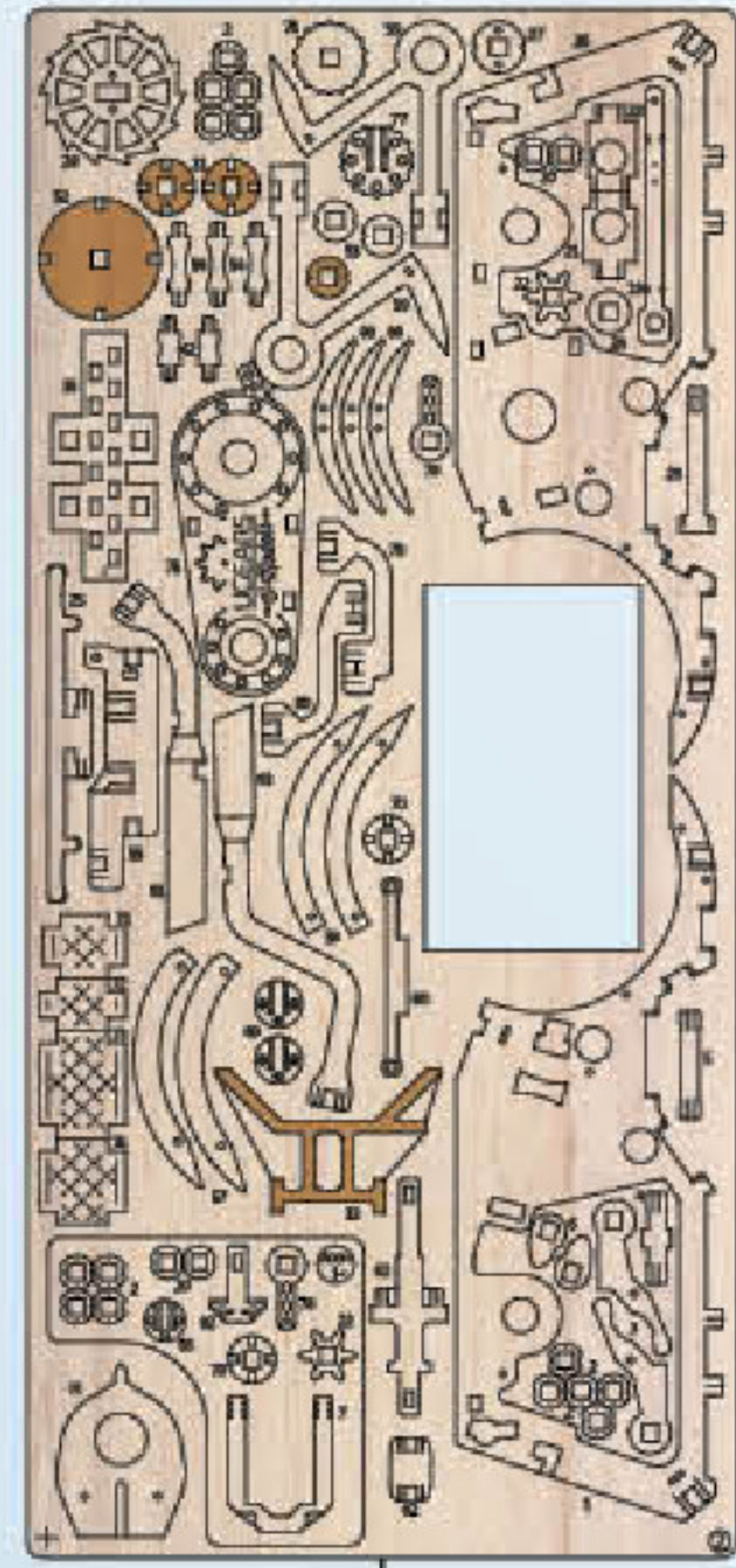

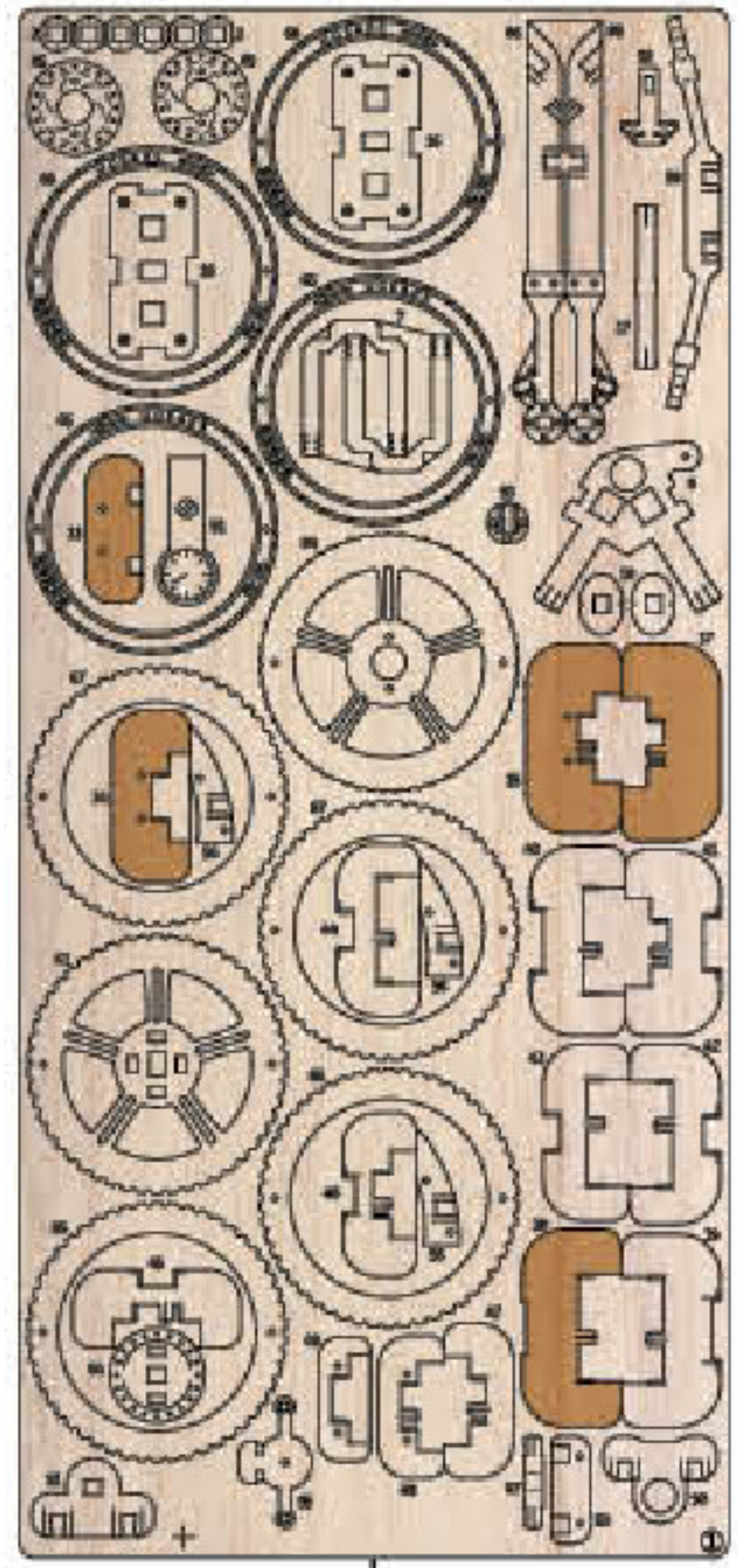

1

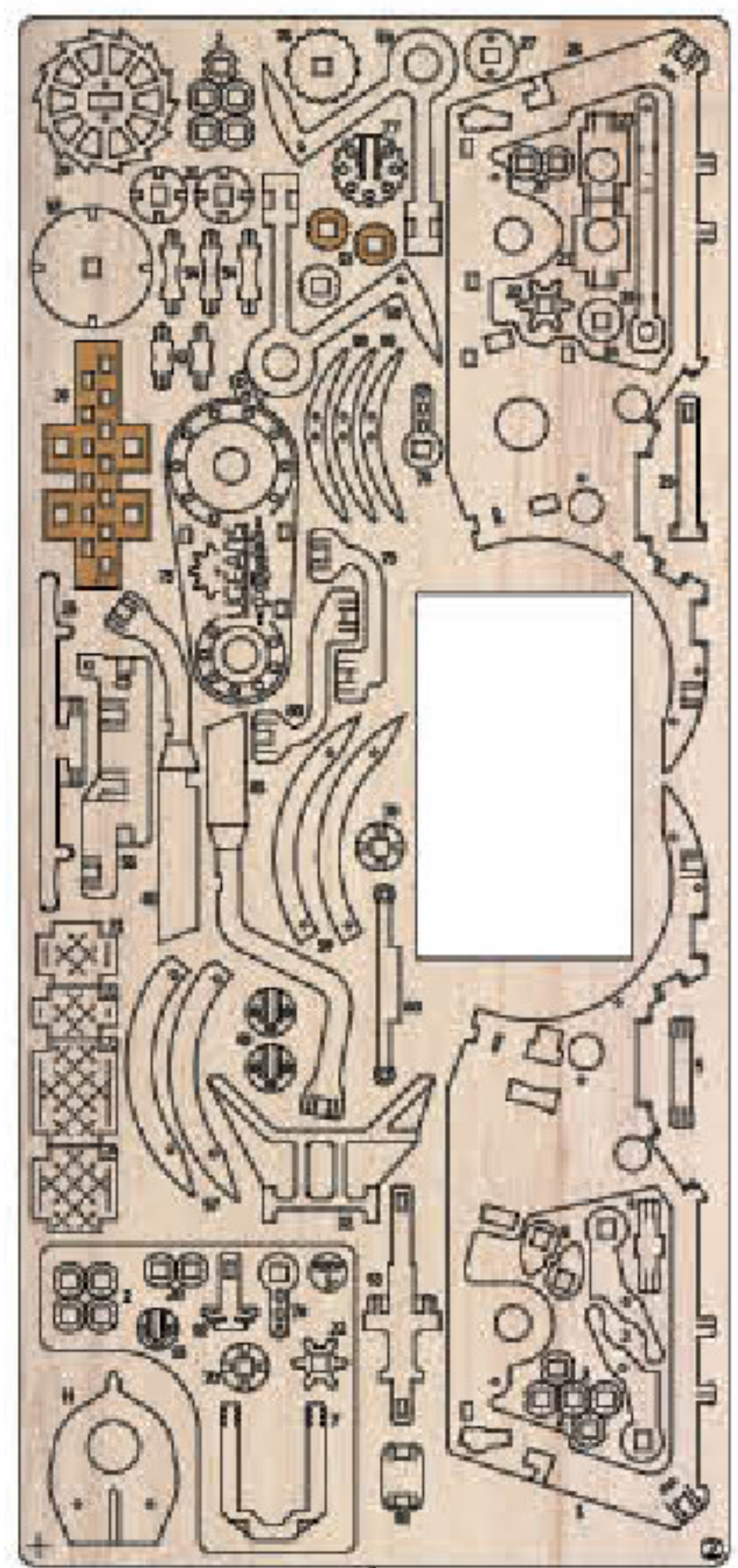

2

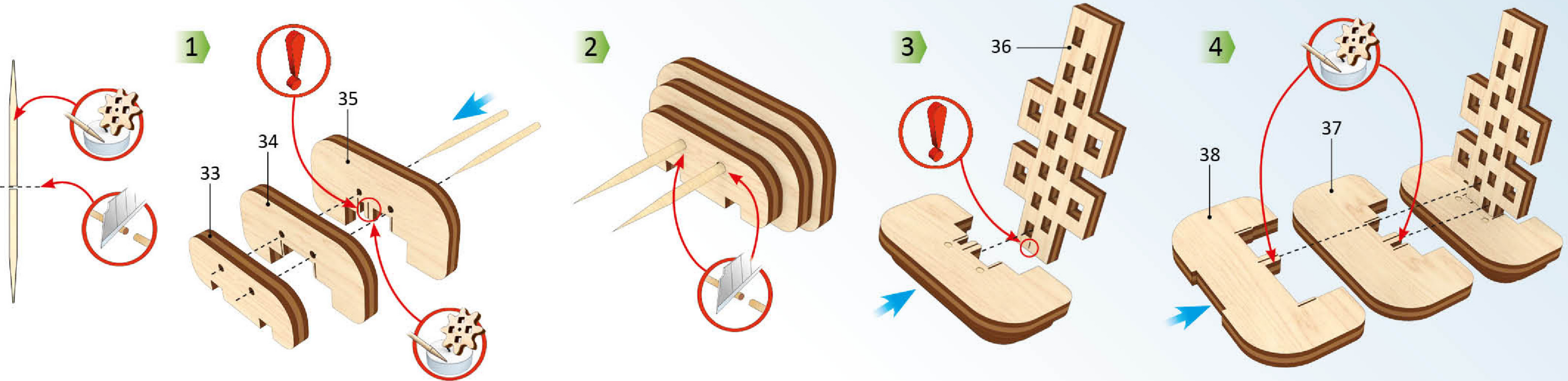

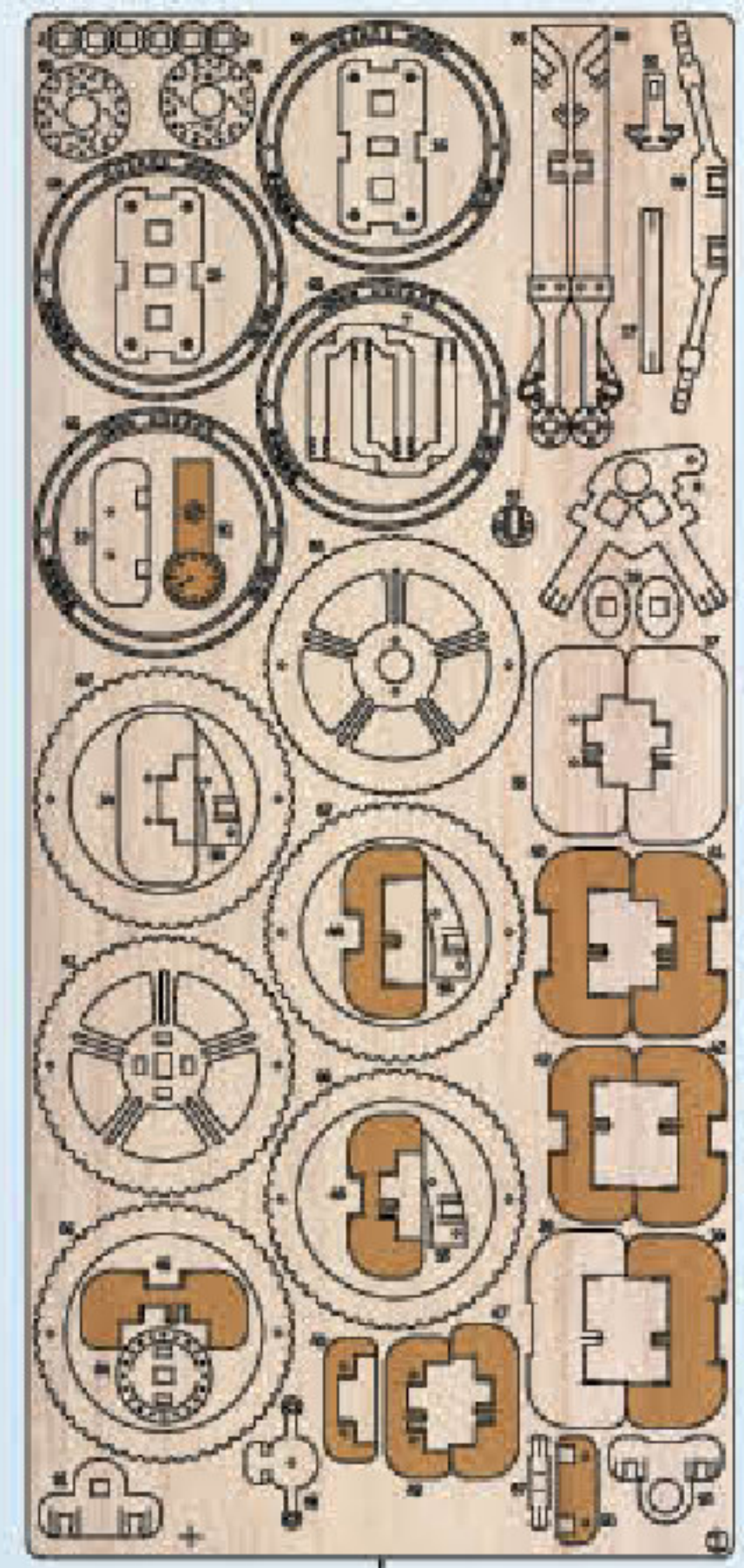

1

1

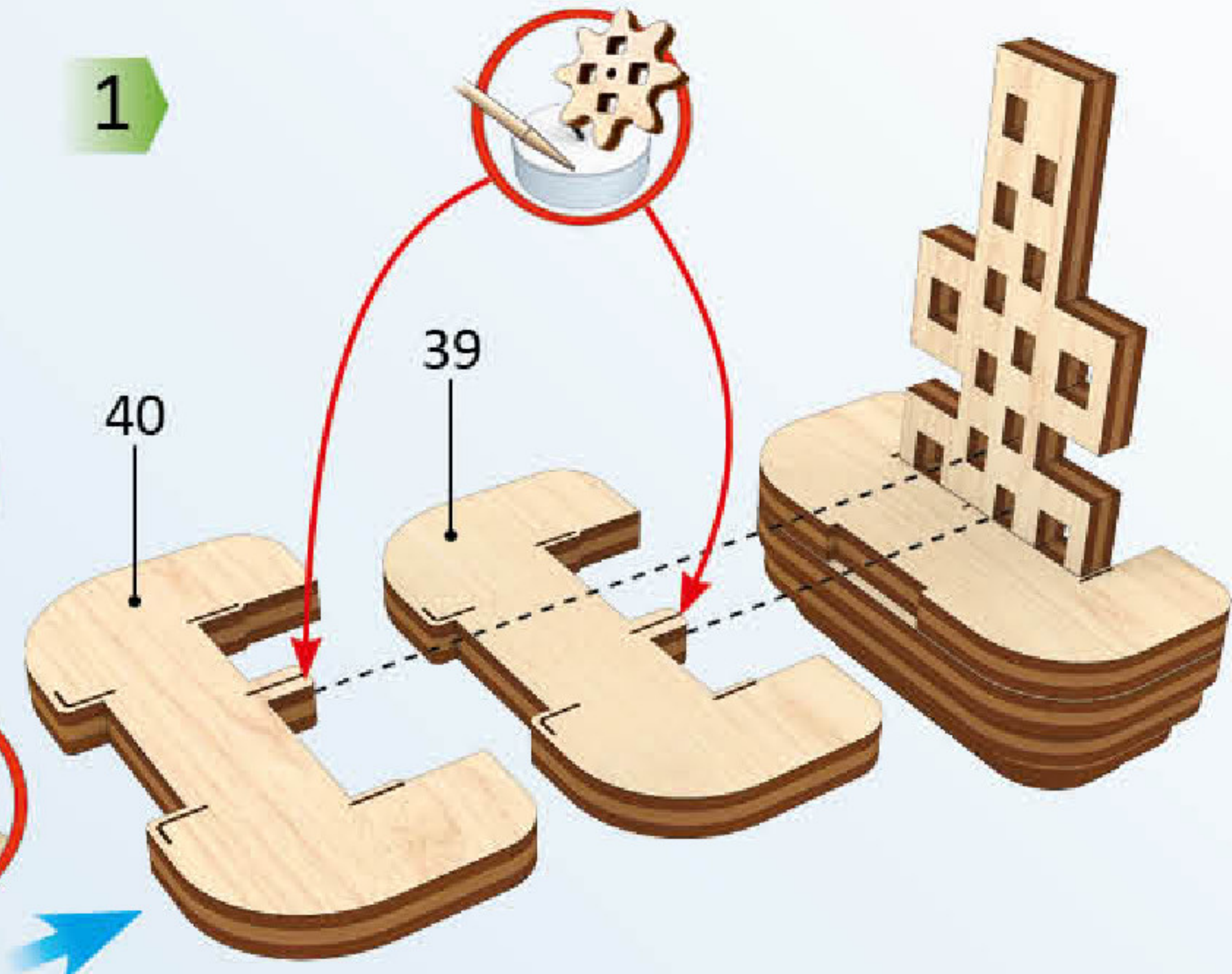

2

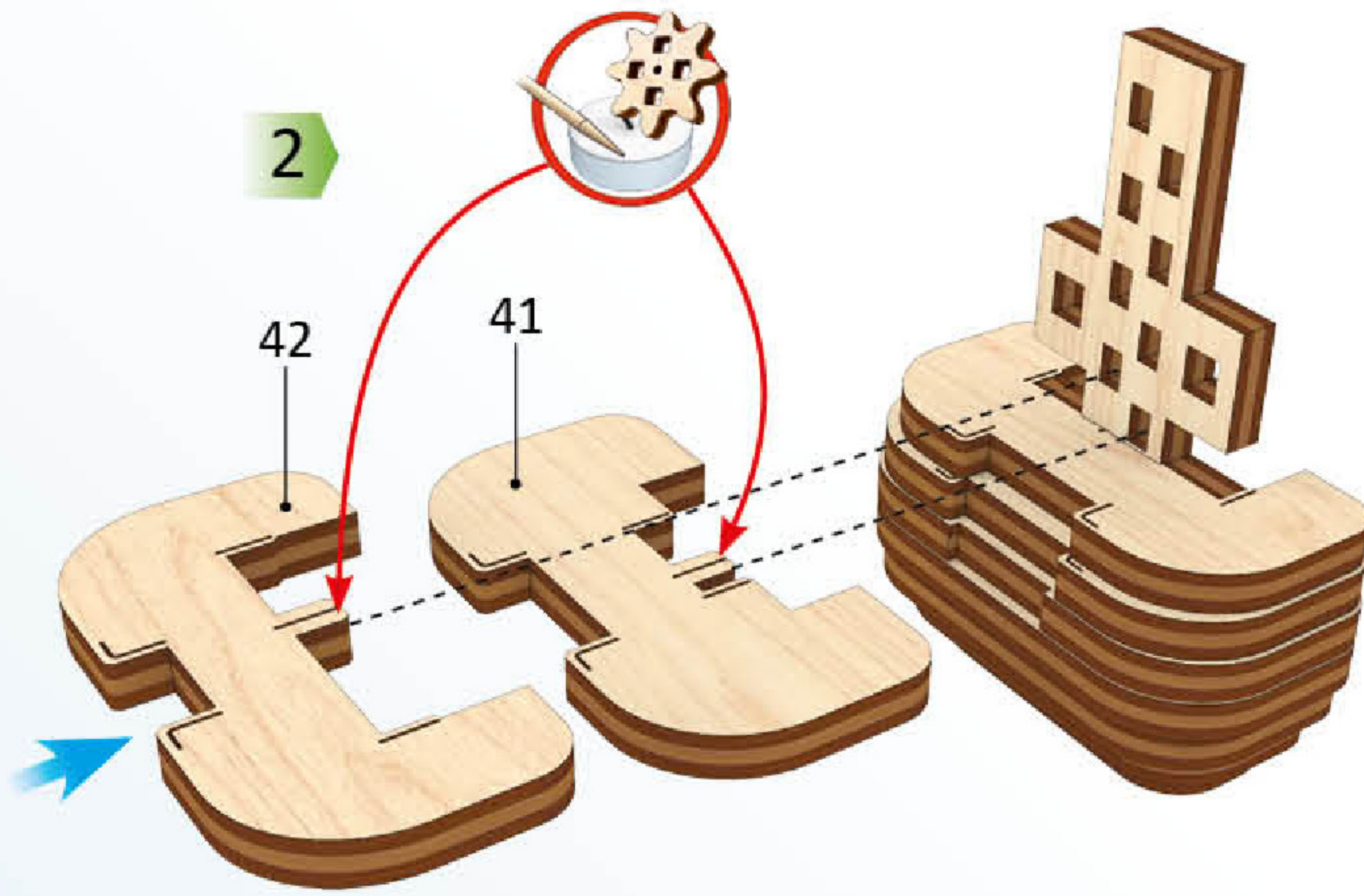

3

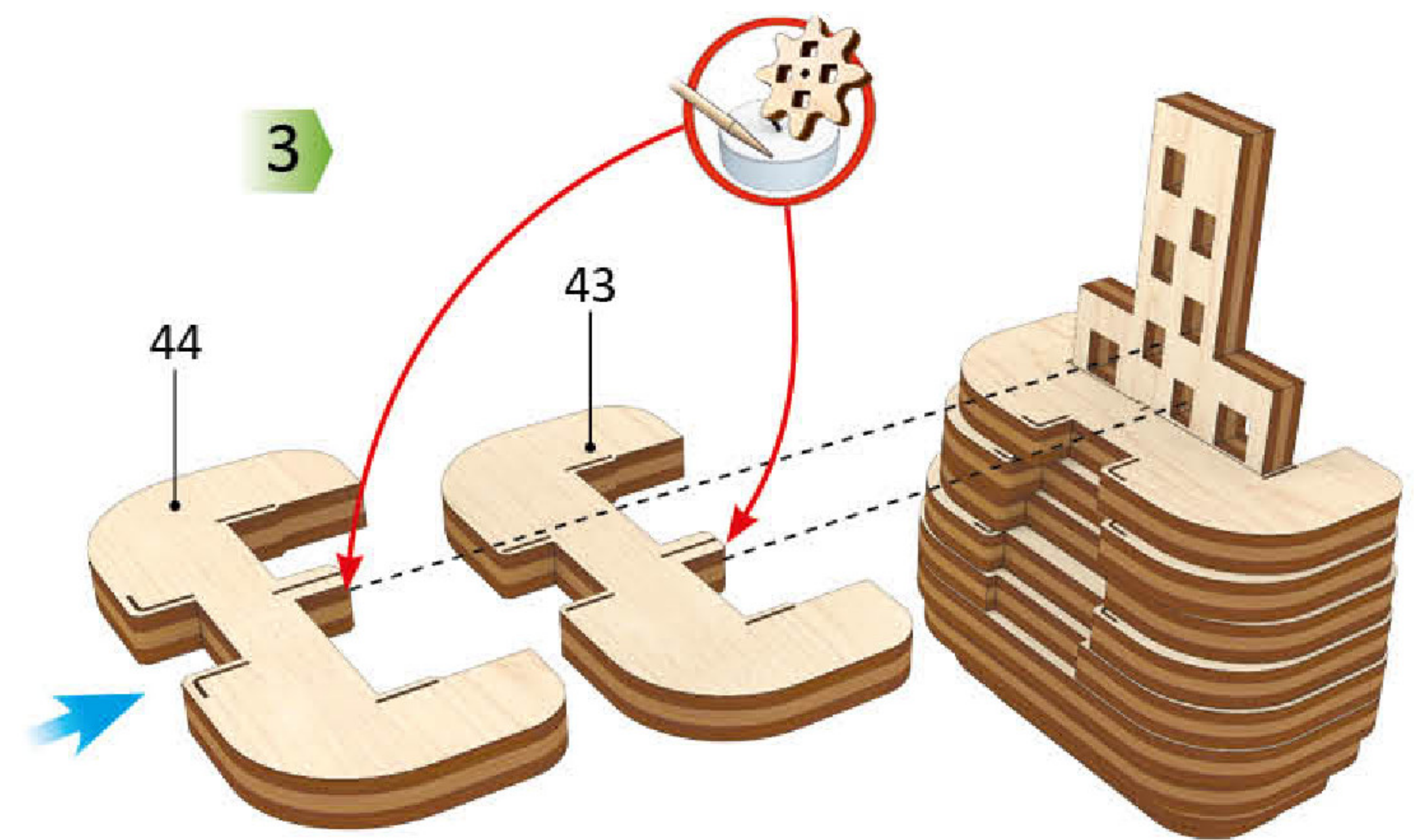

4

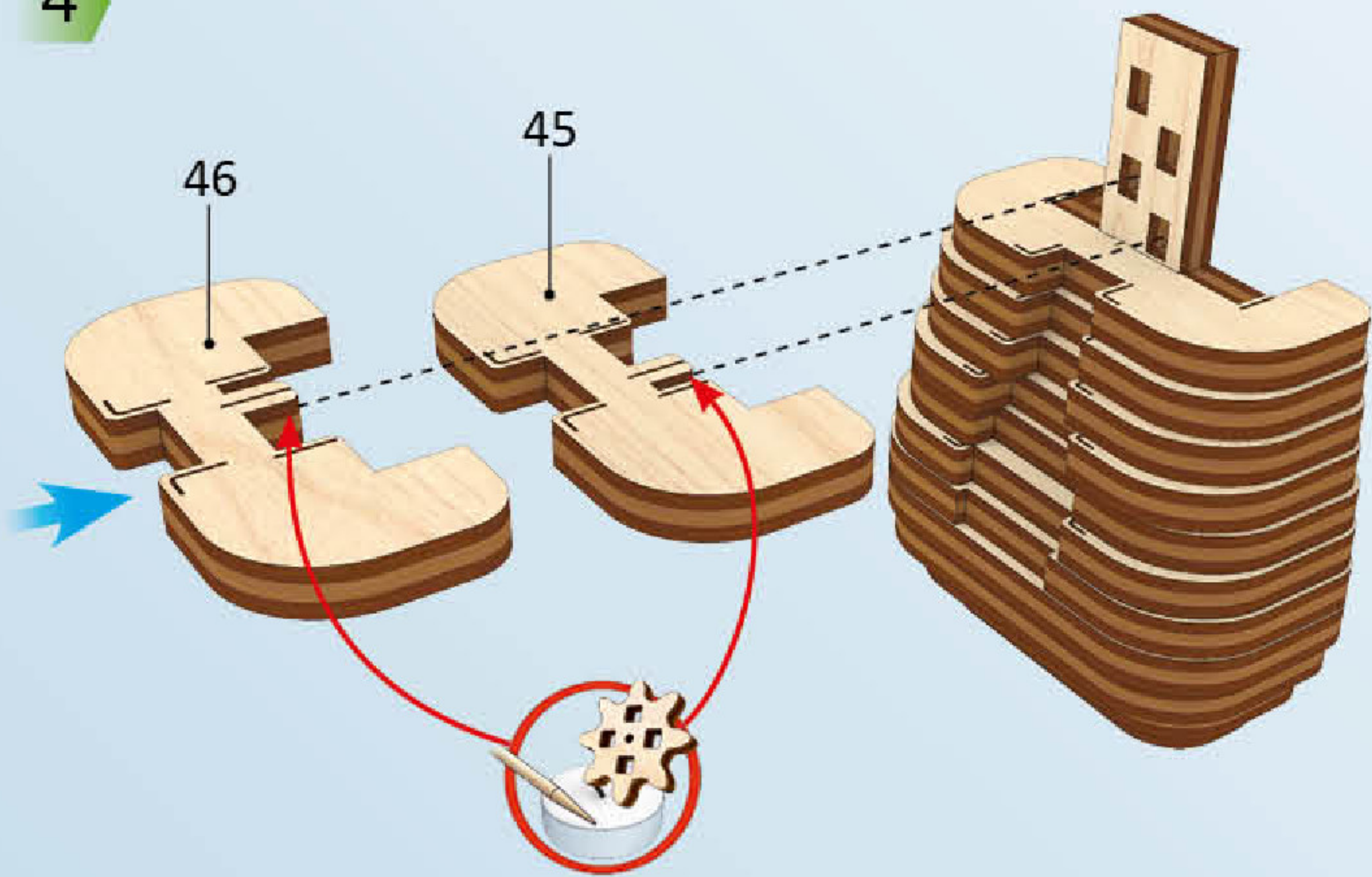

5

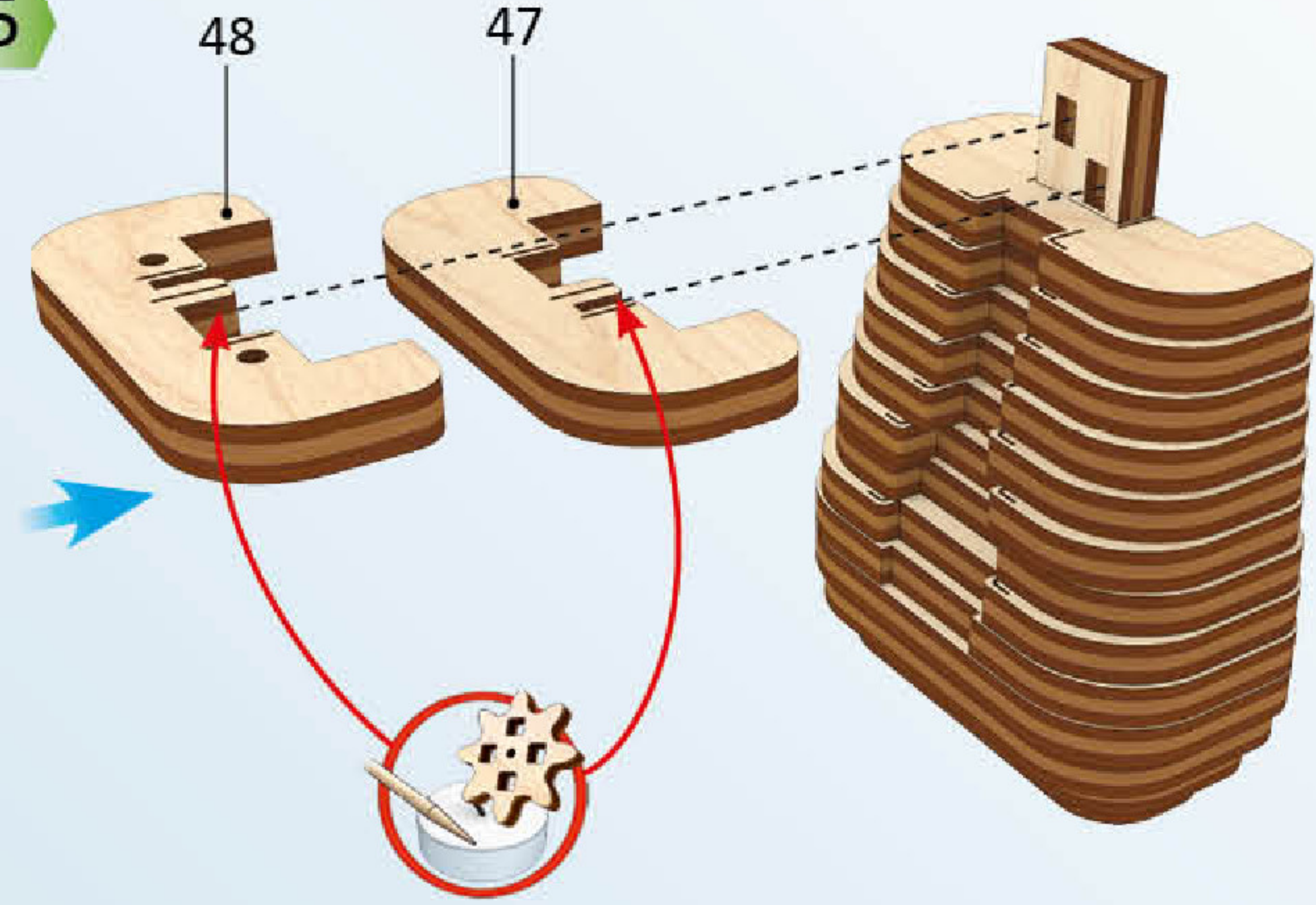

6



7



8

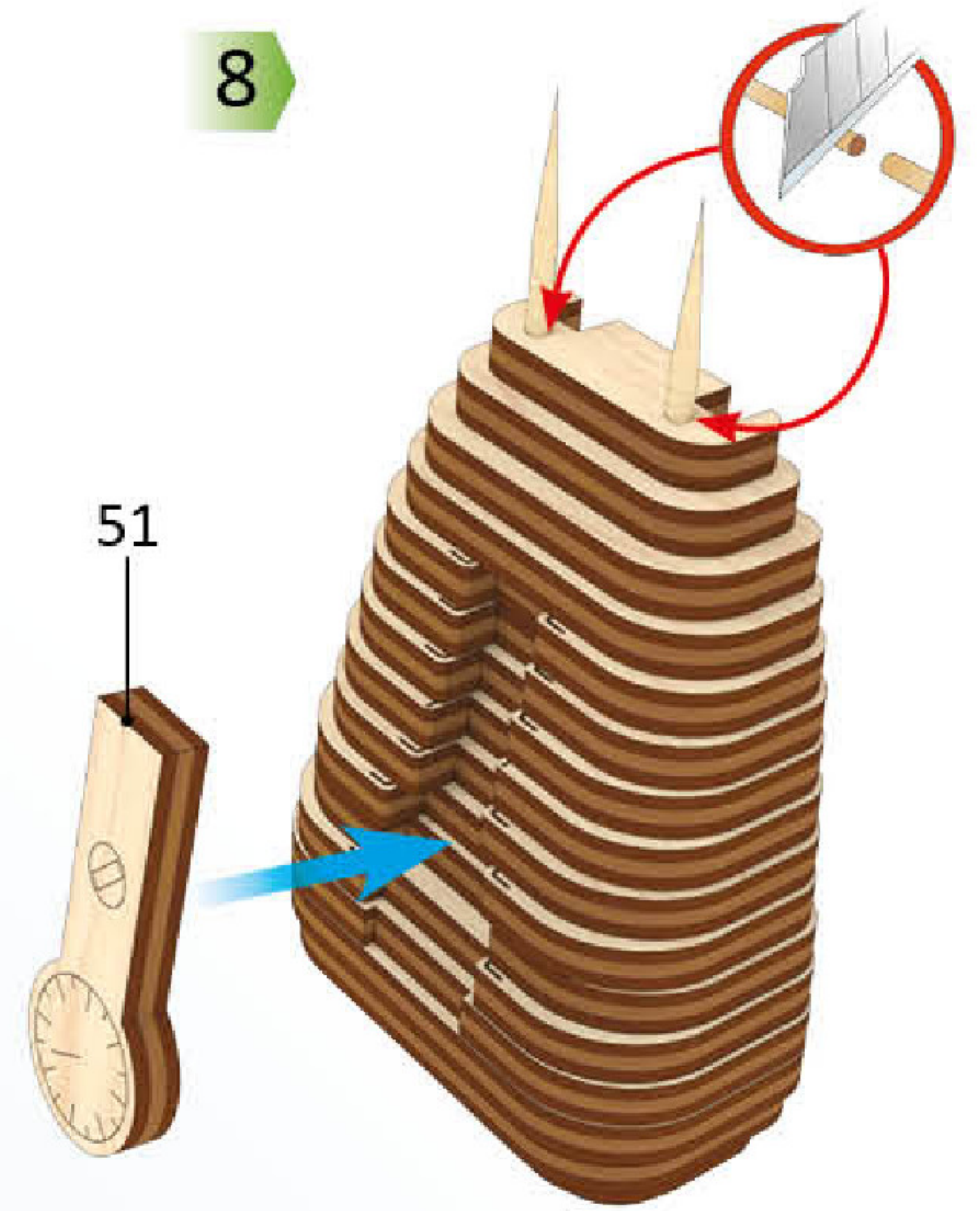

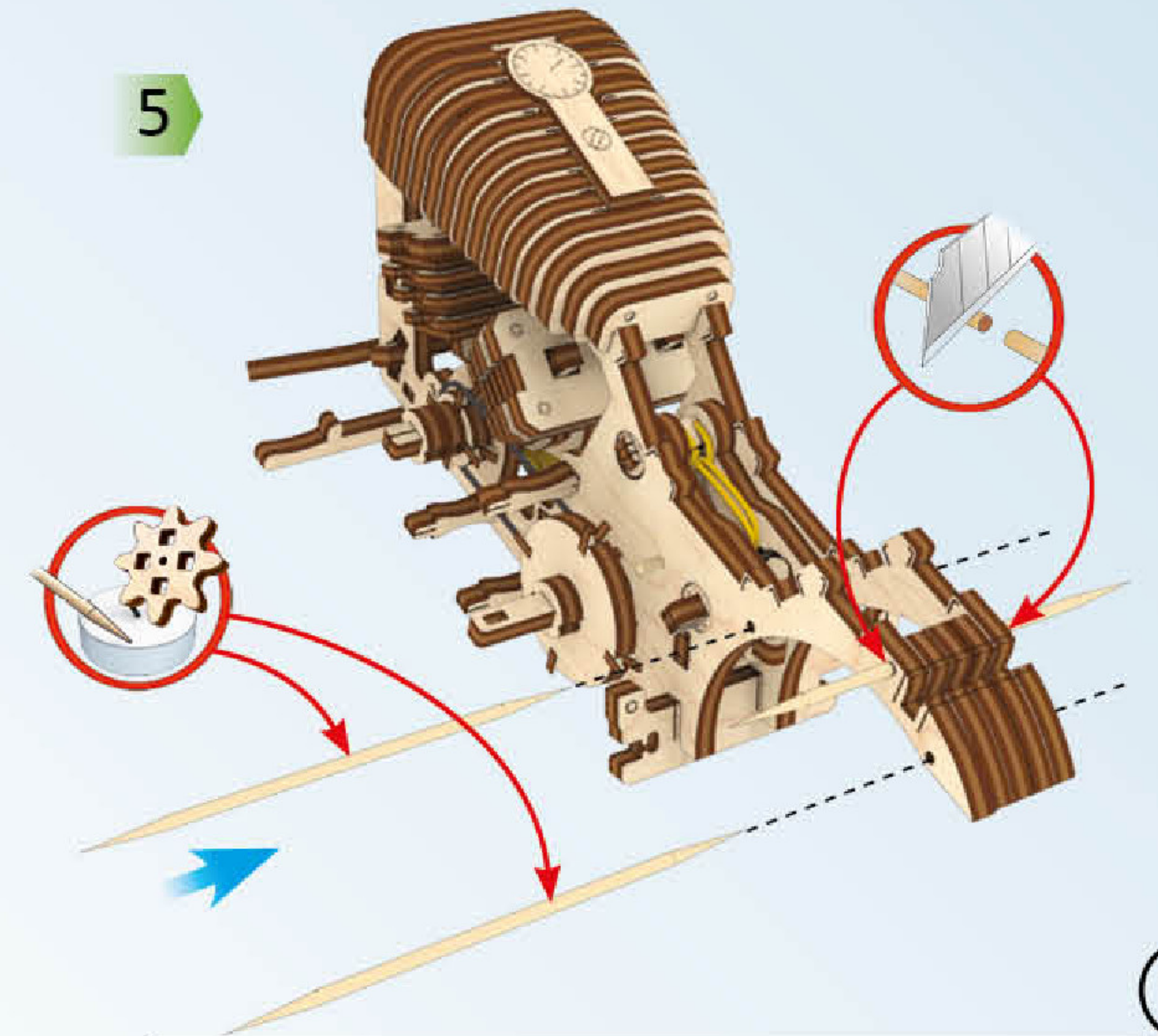
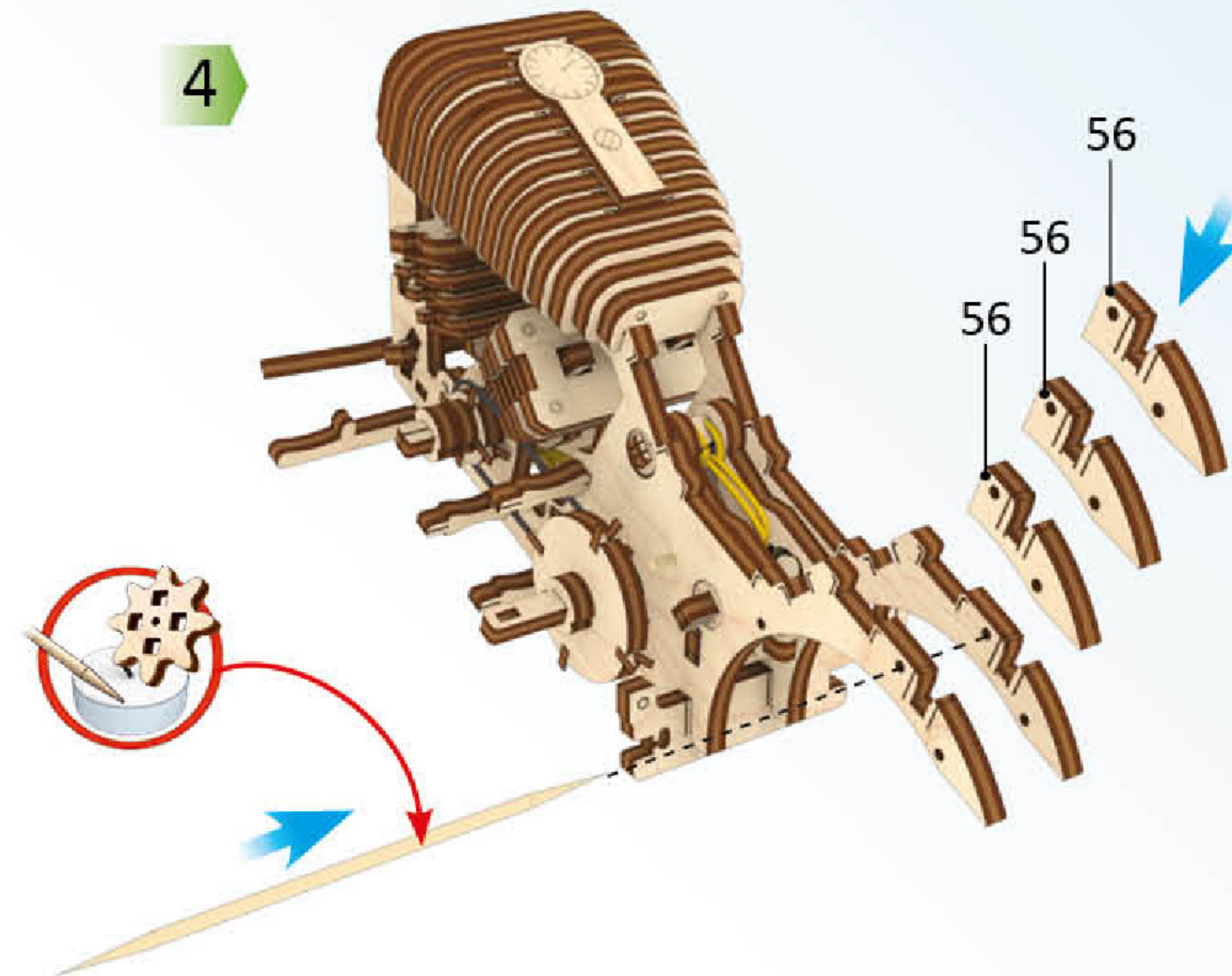
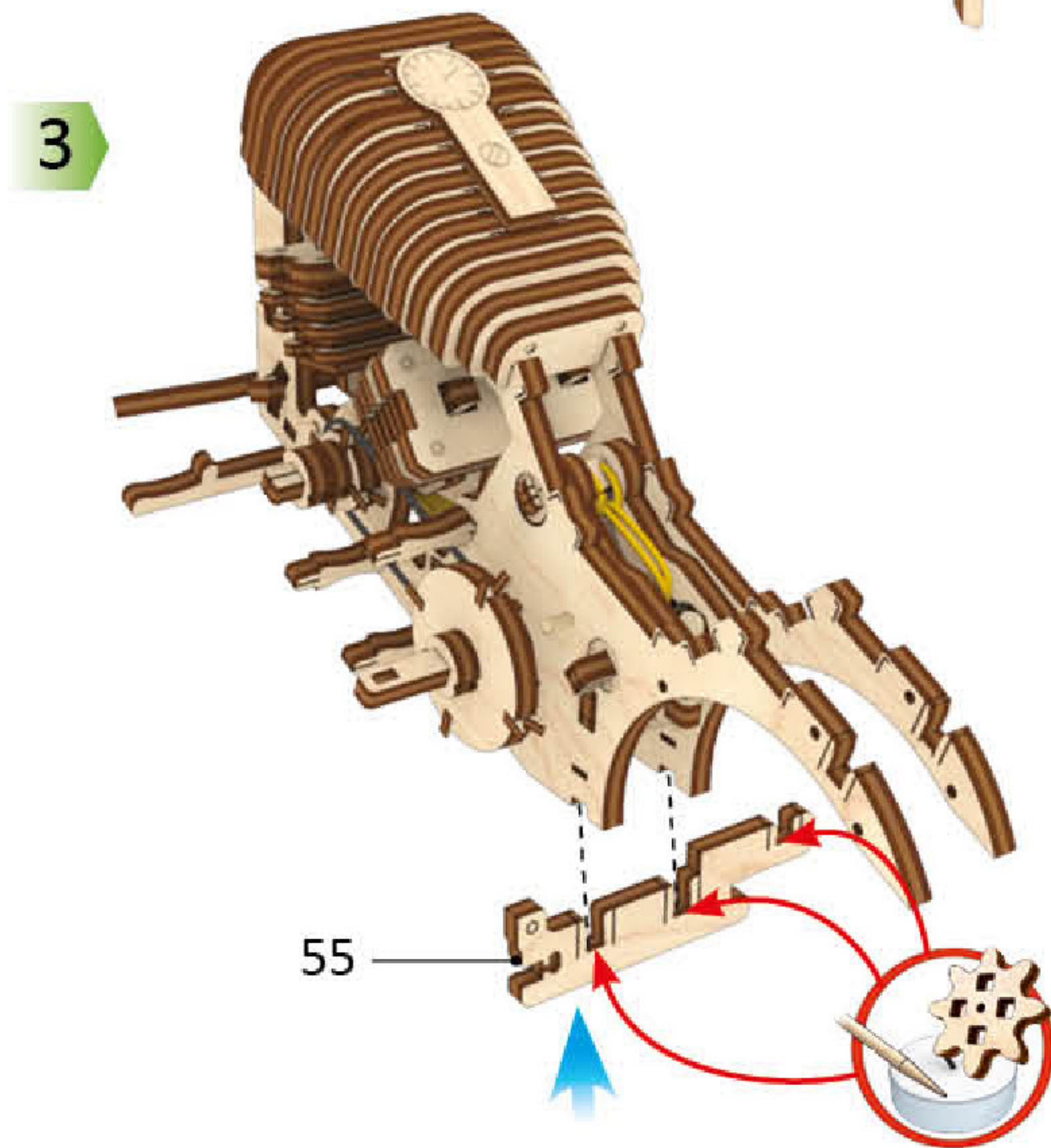
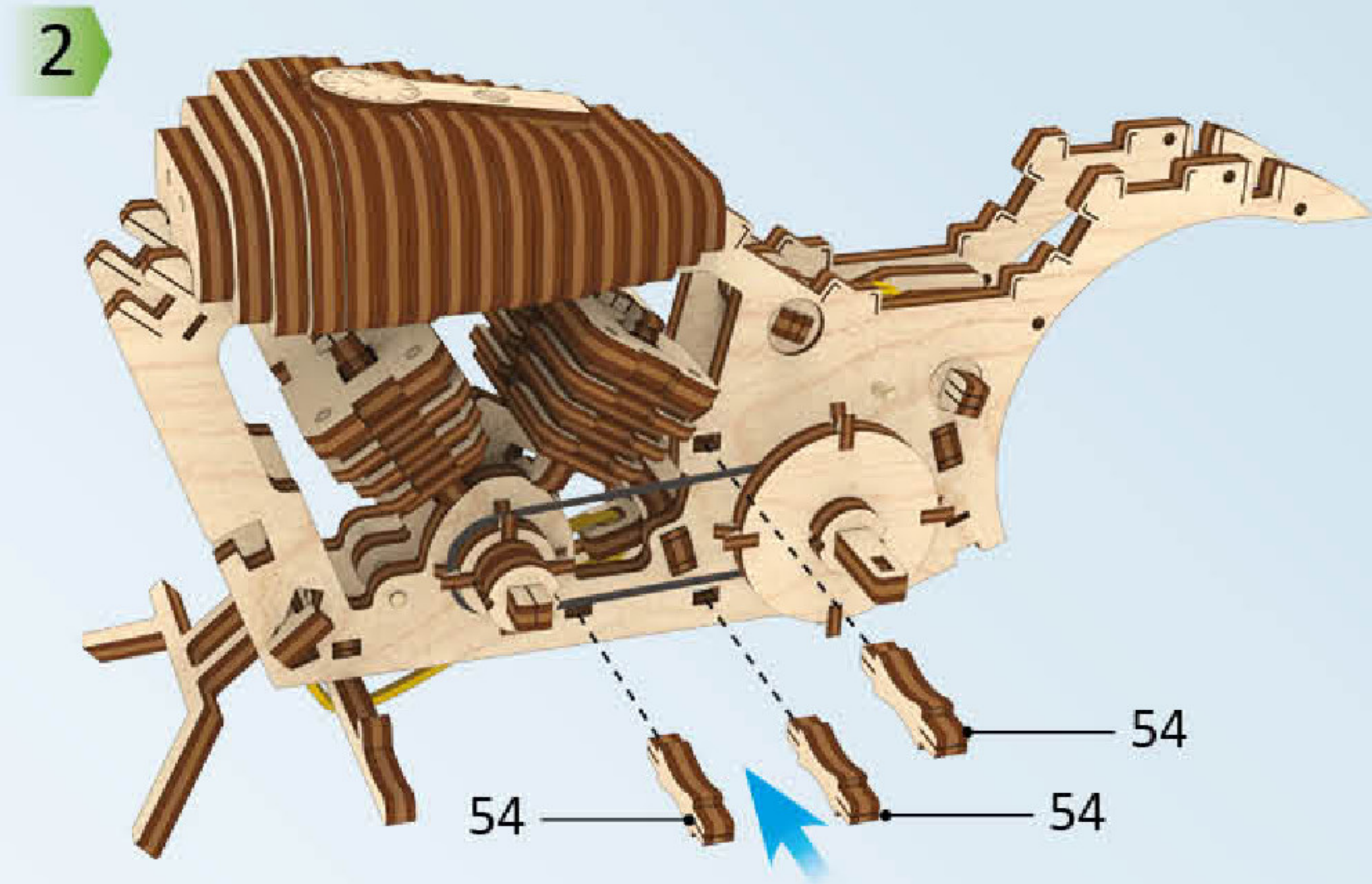
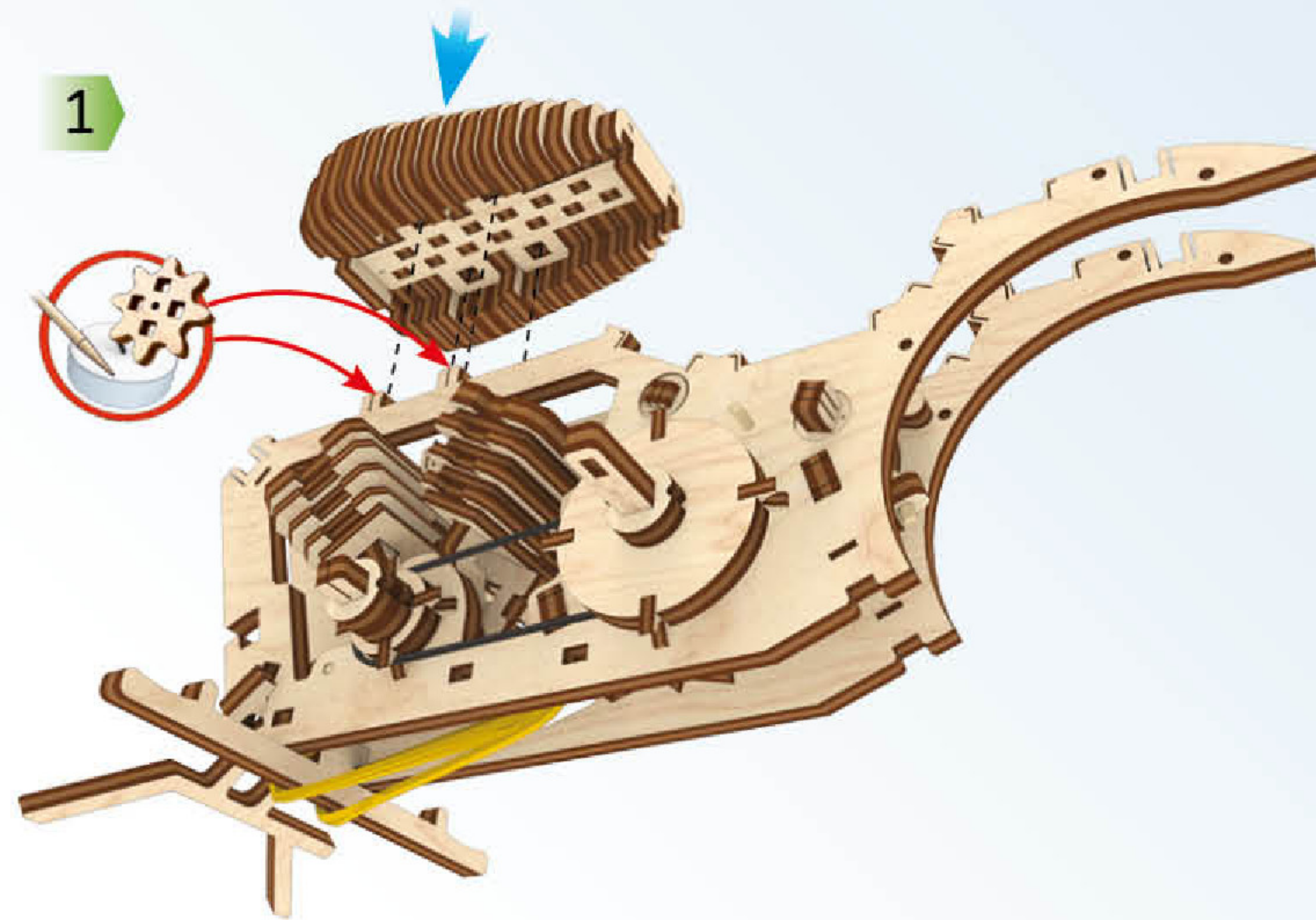
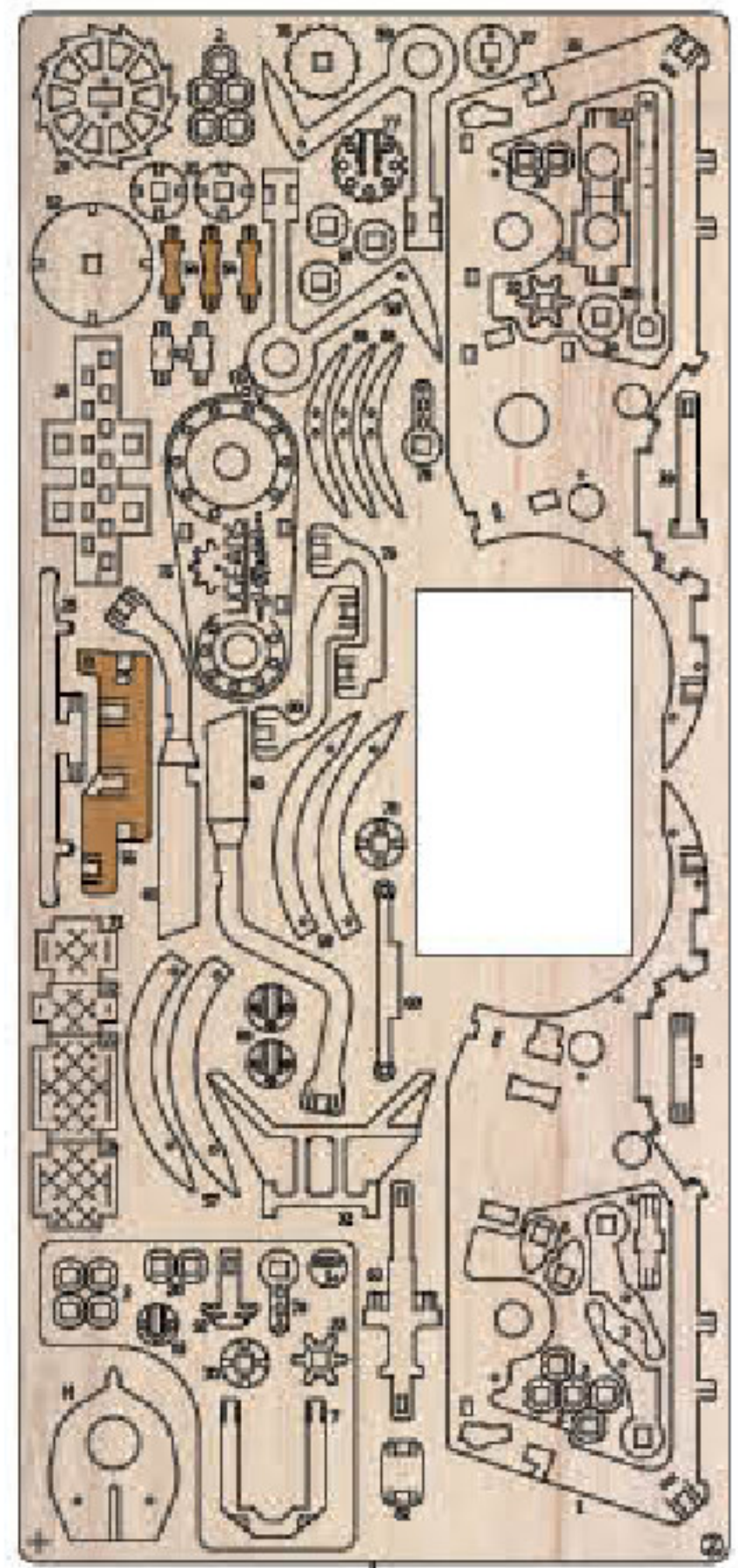
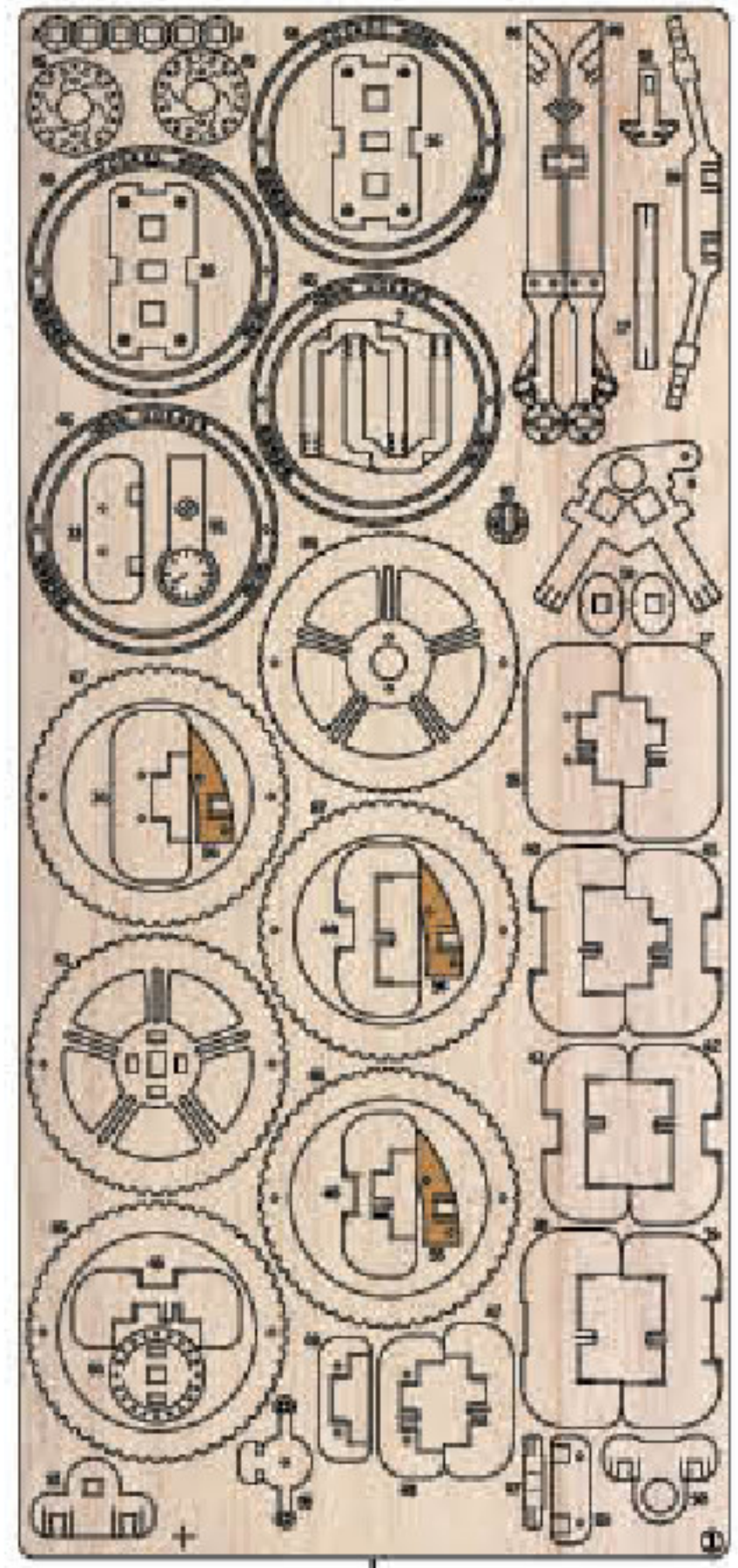

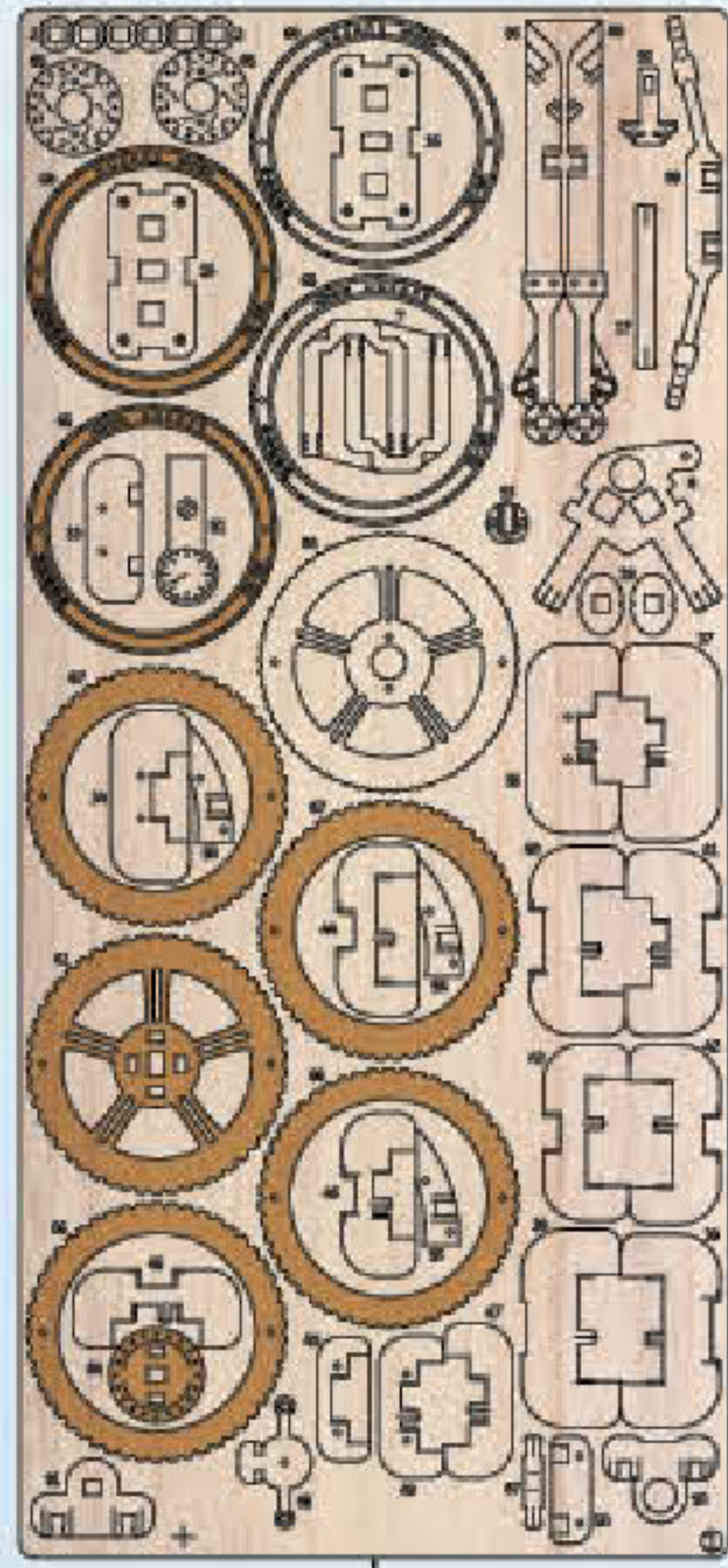

1

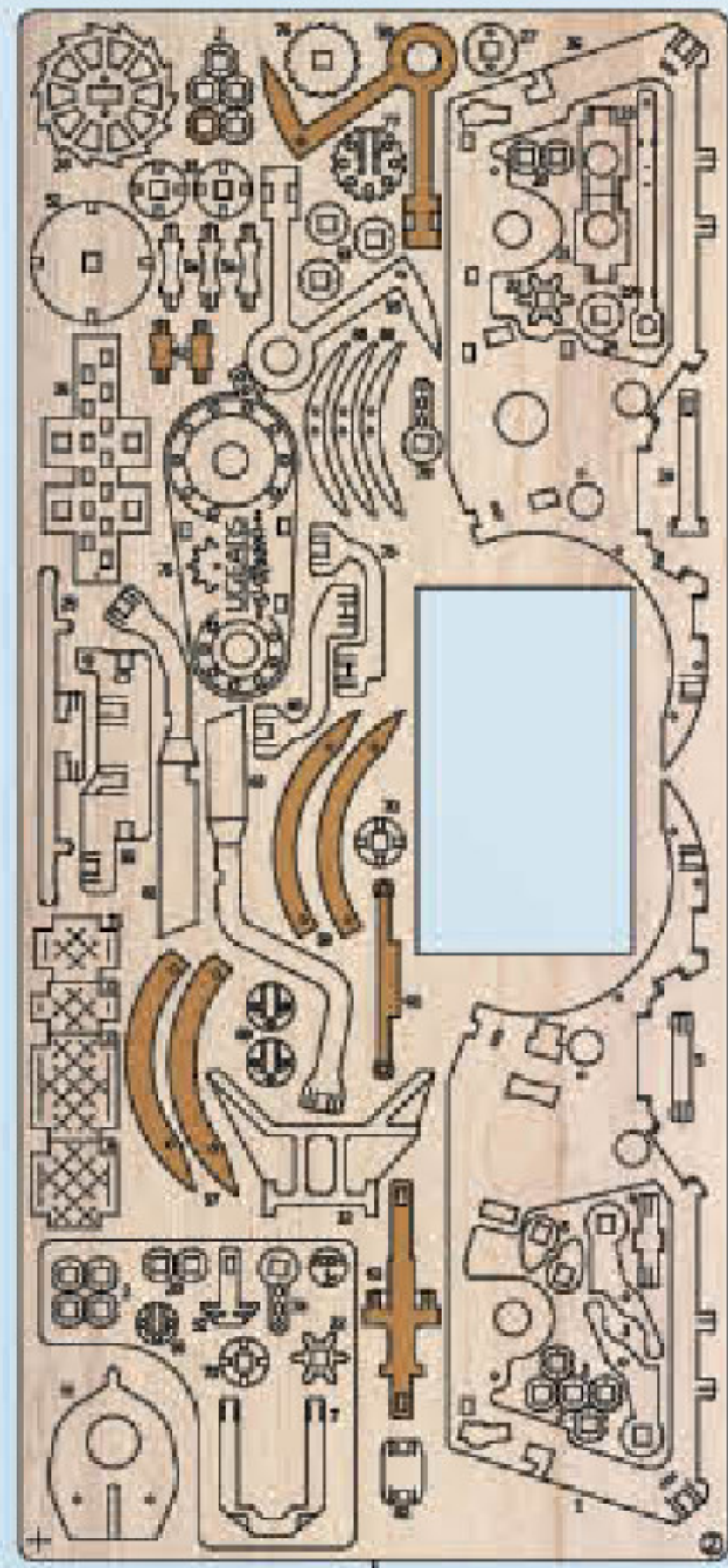

2

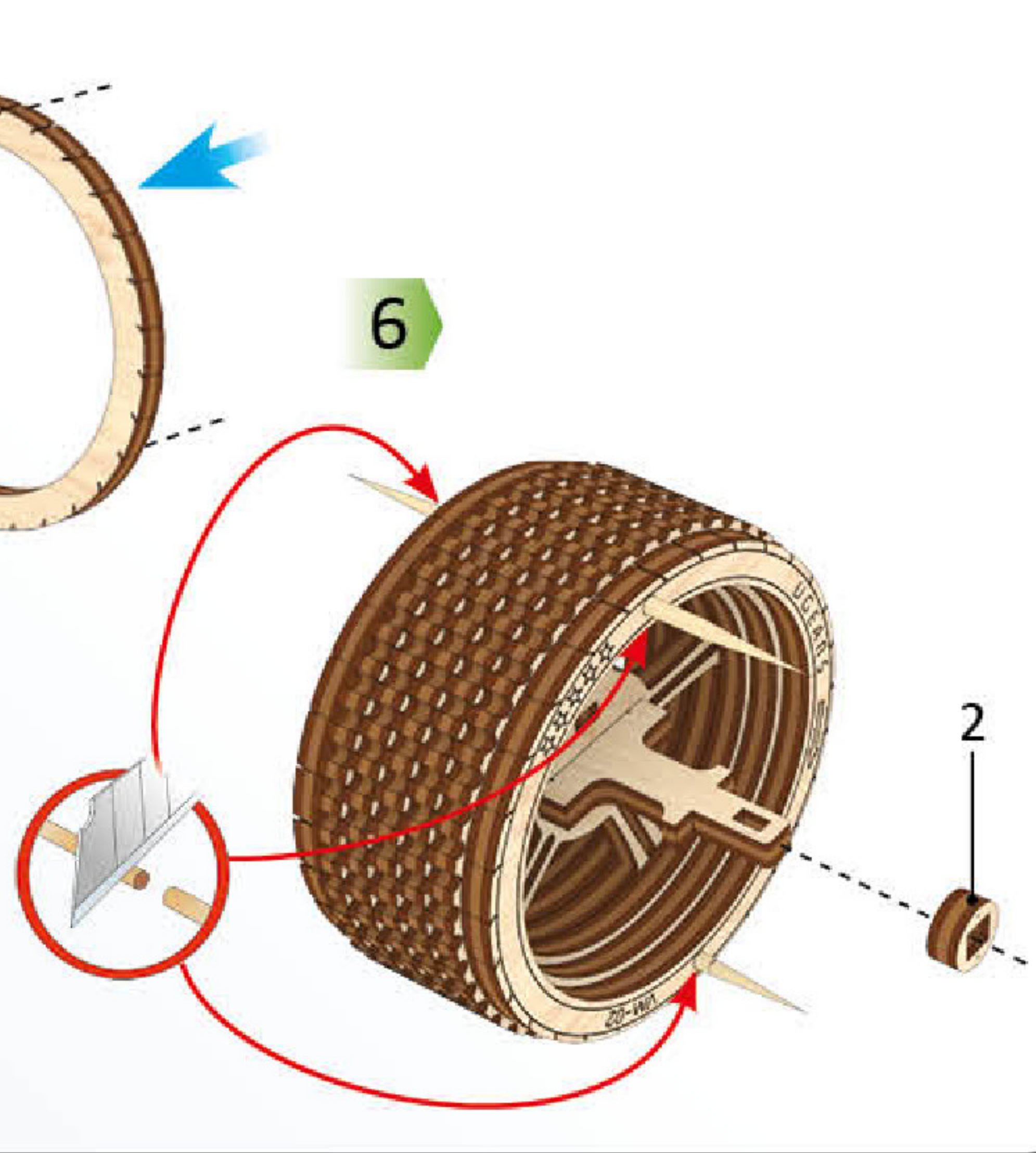
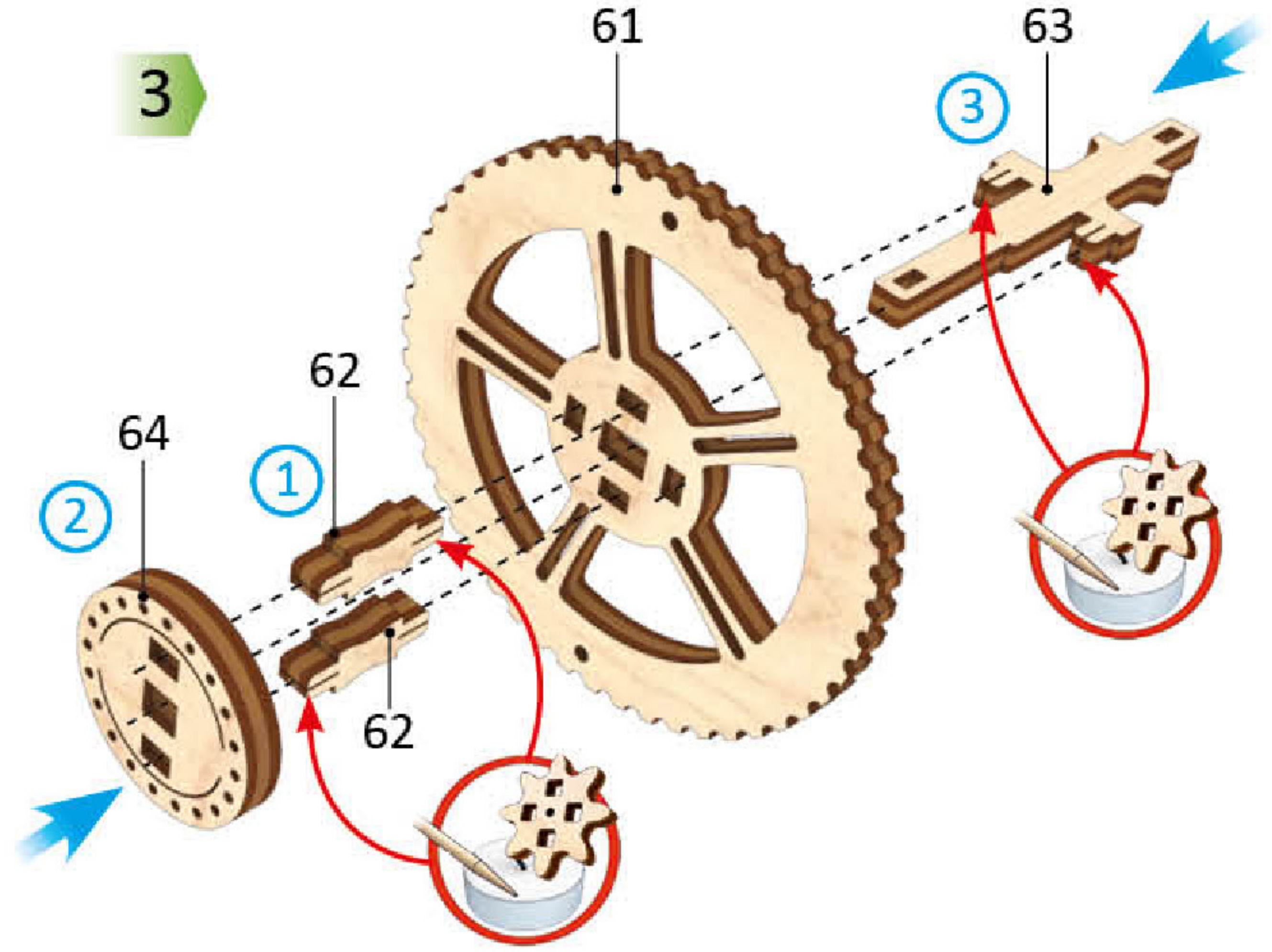
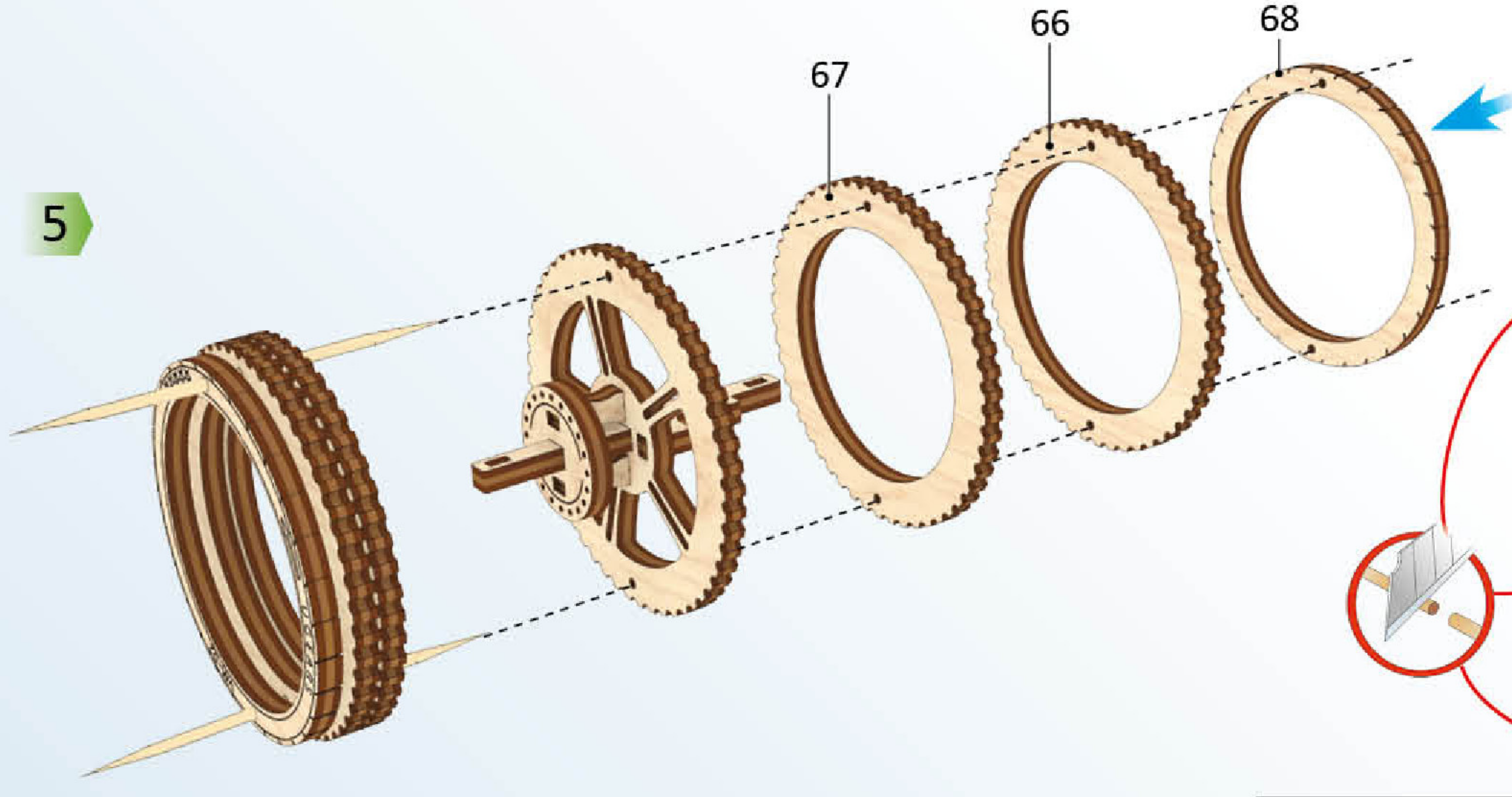
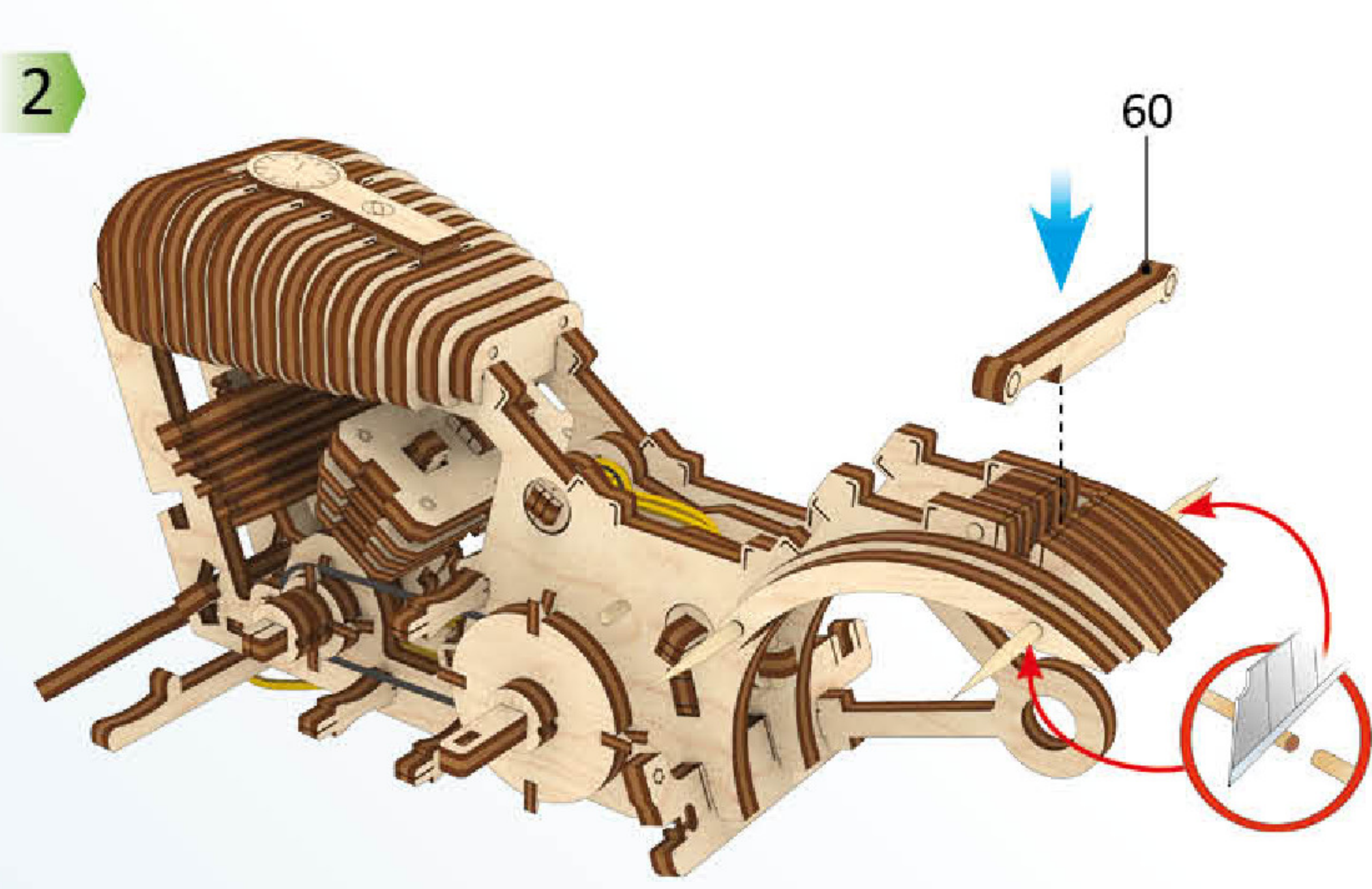
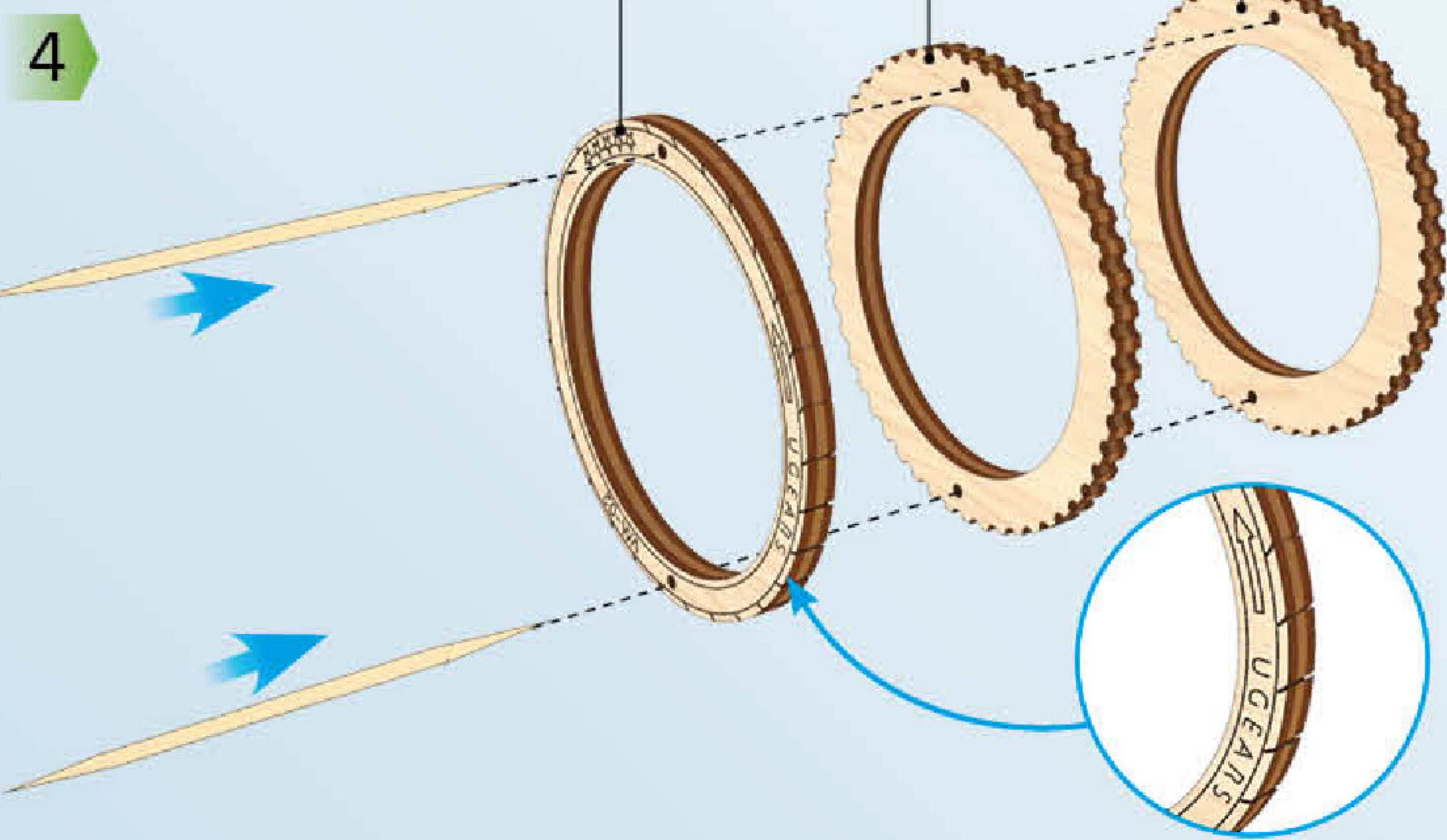
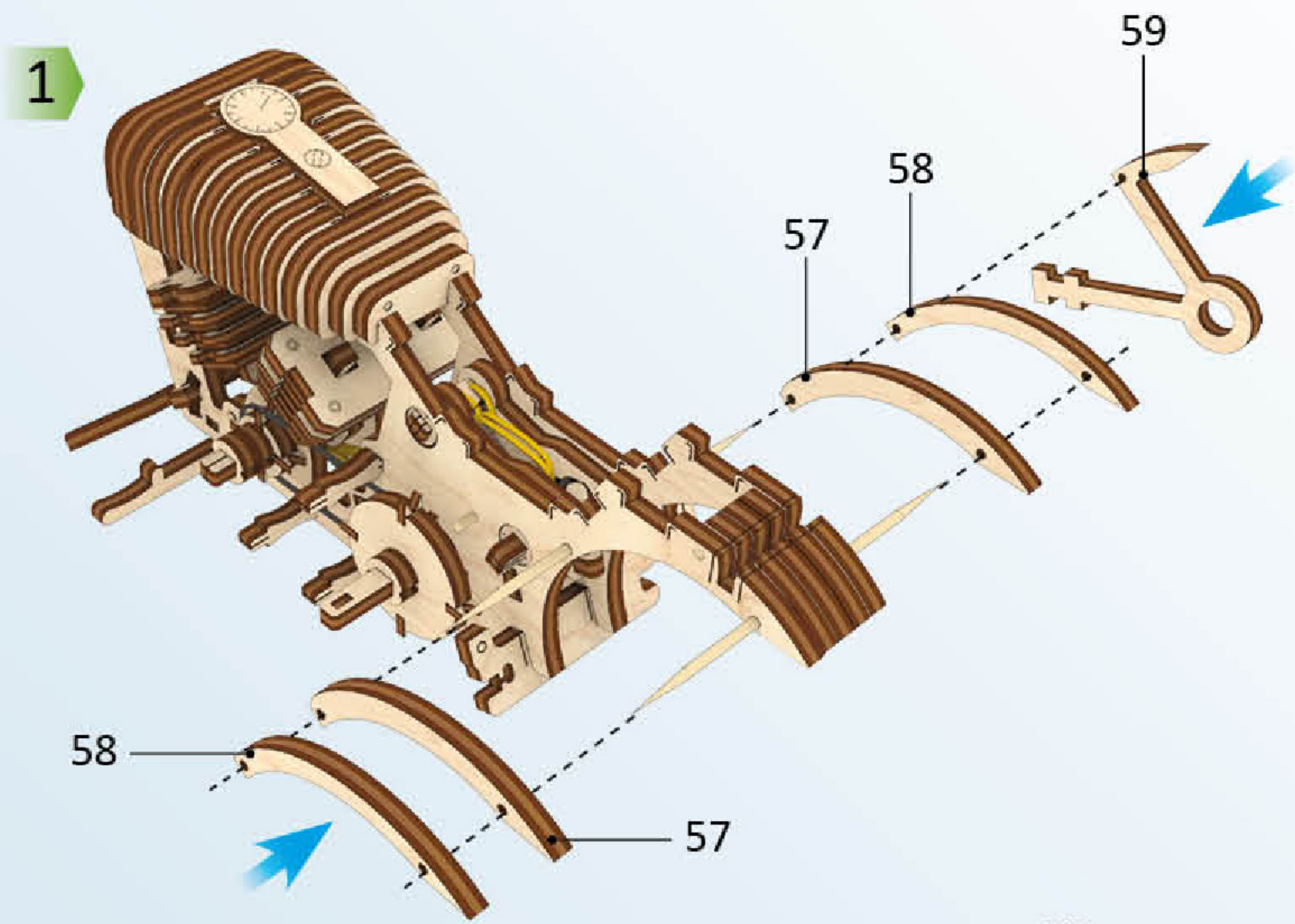

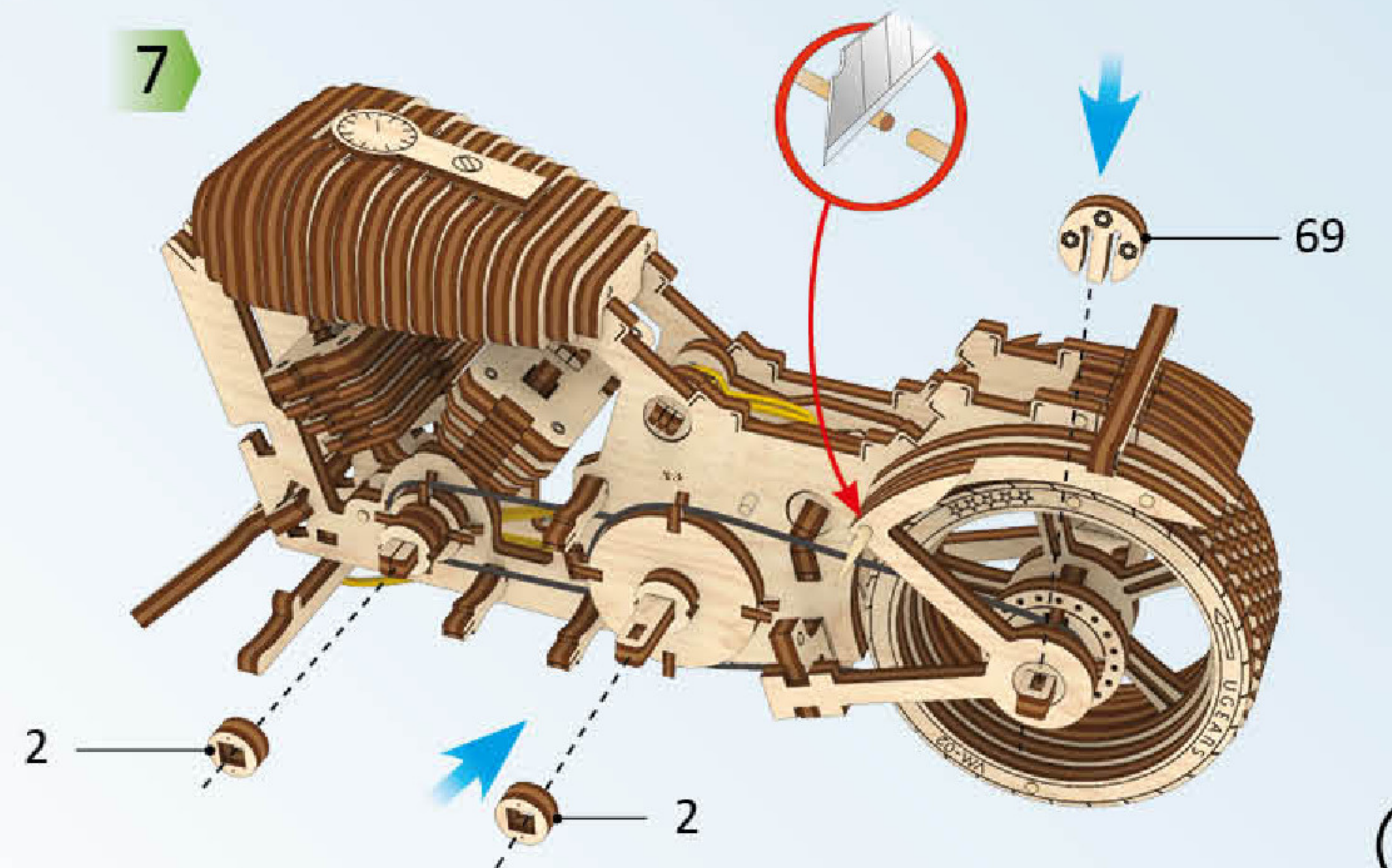
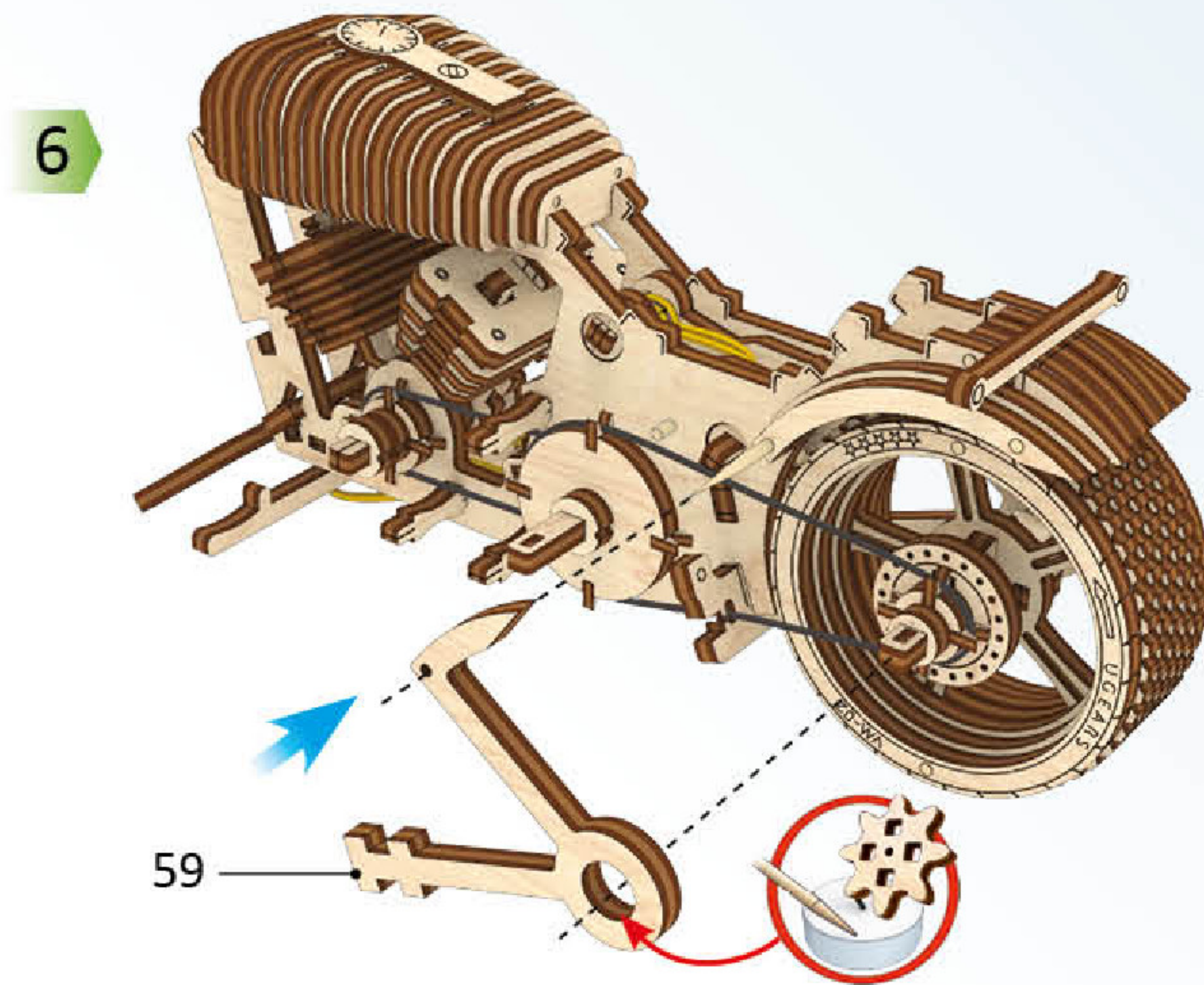
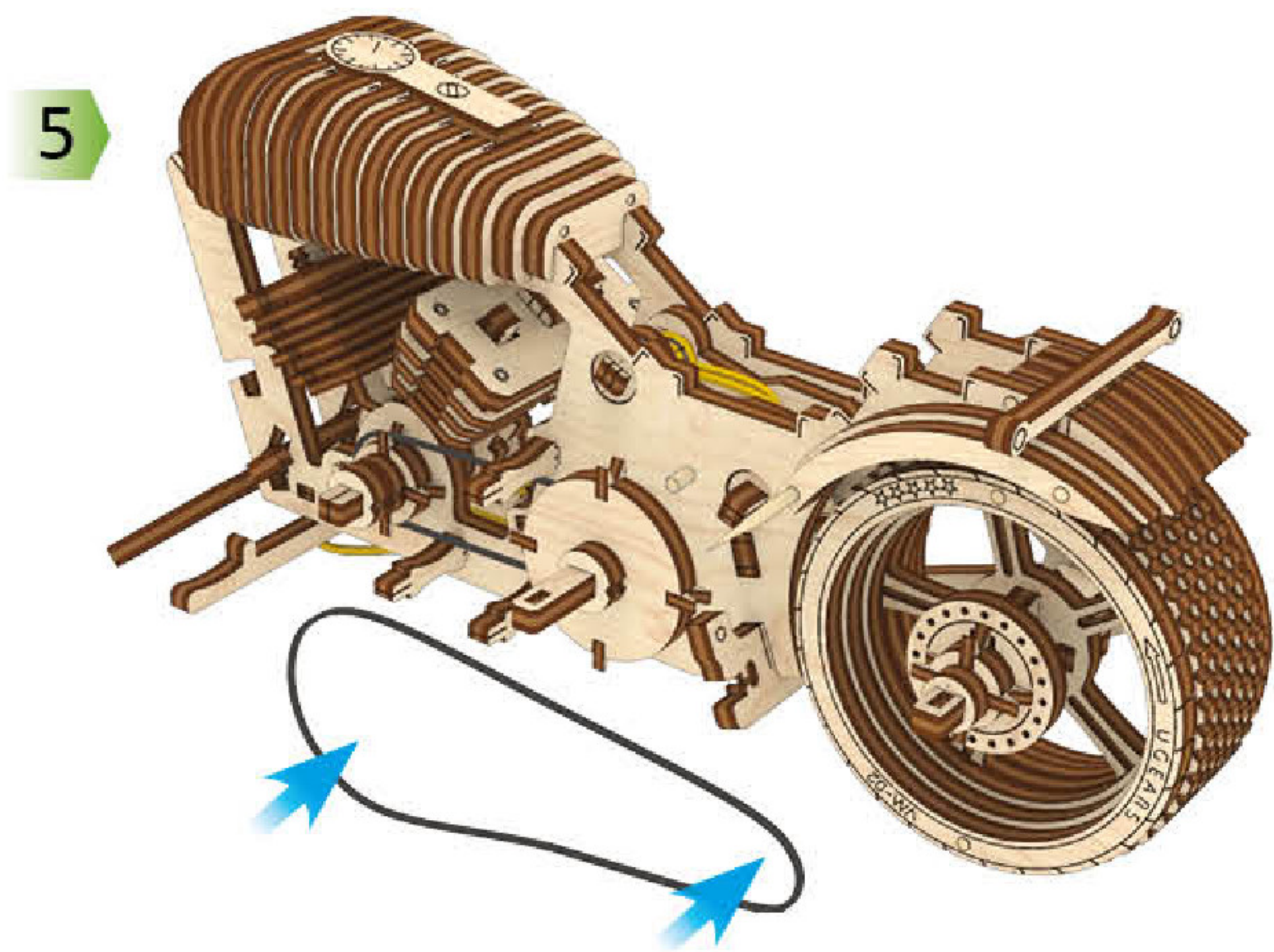
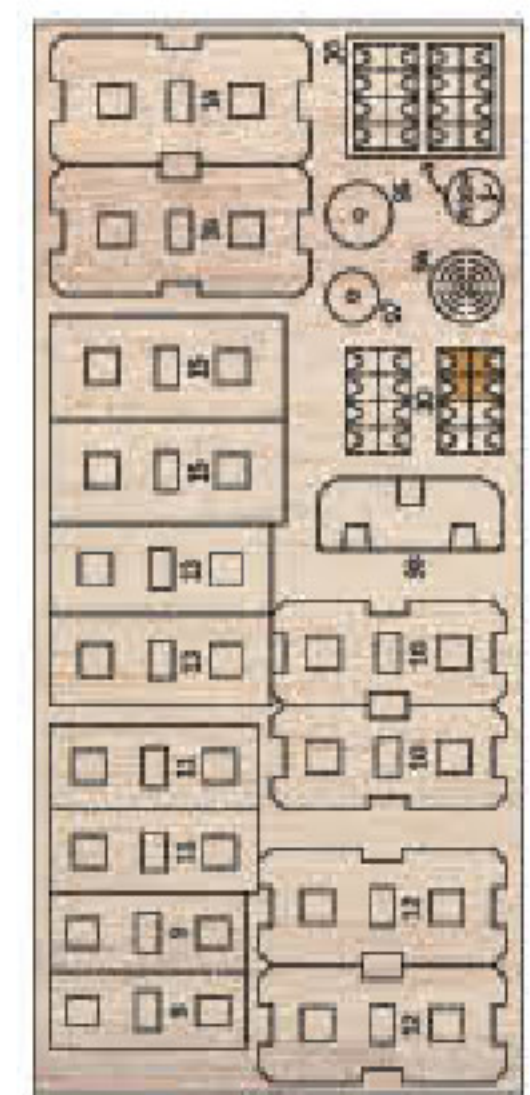
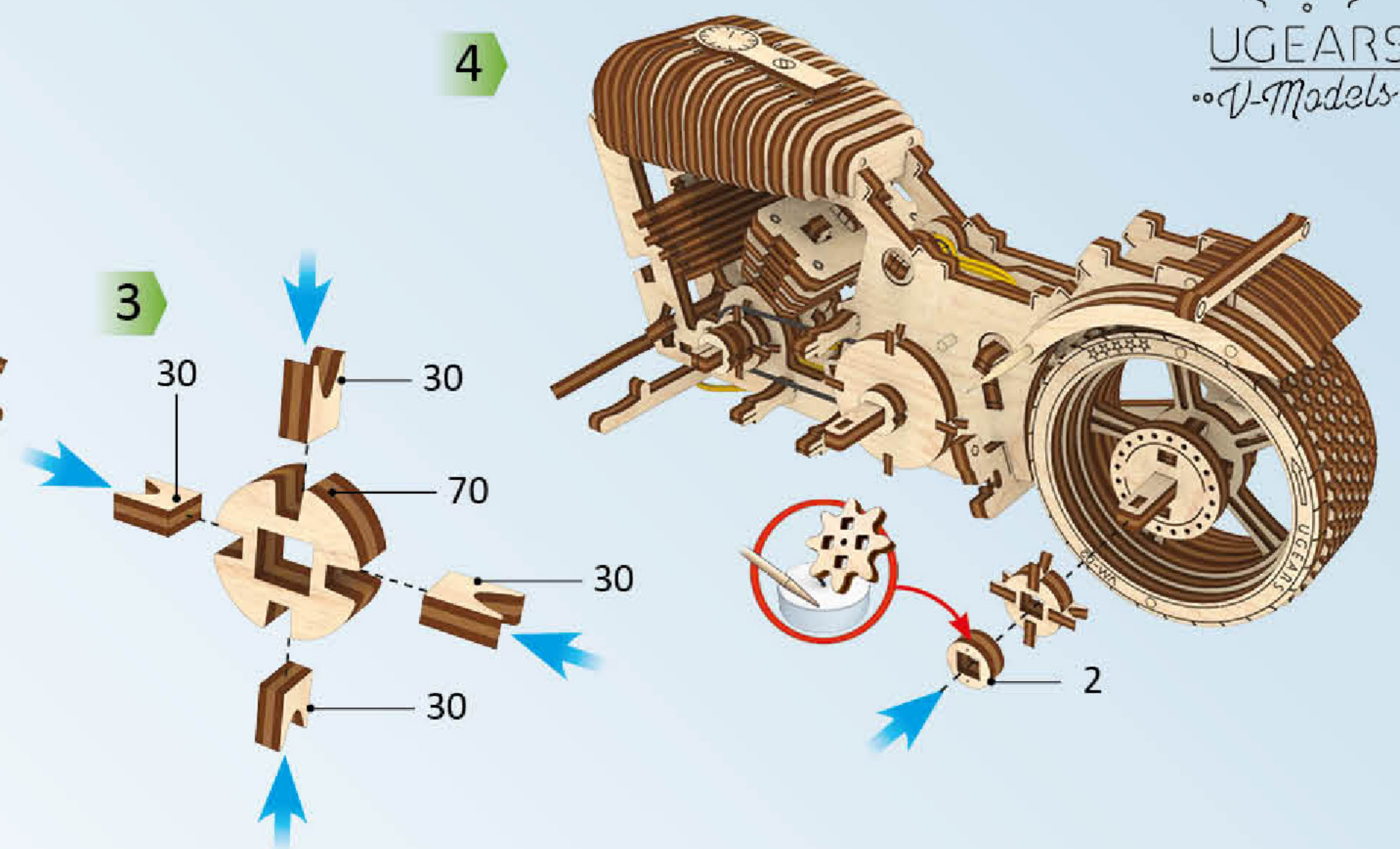
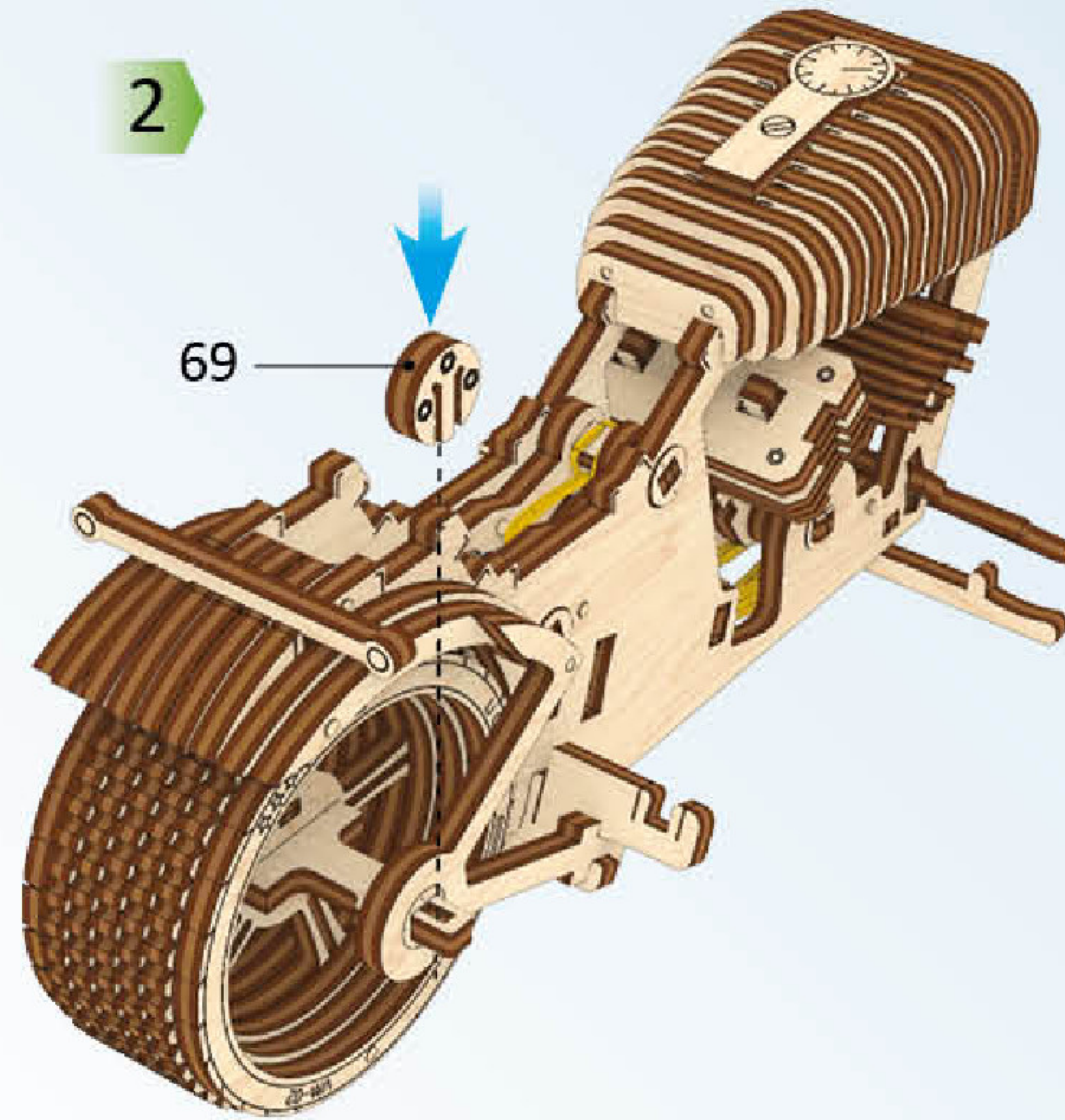
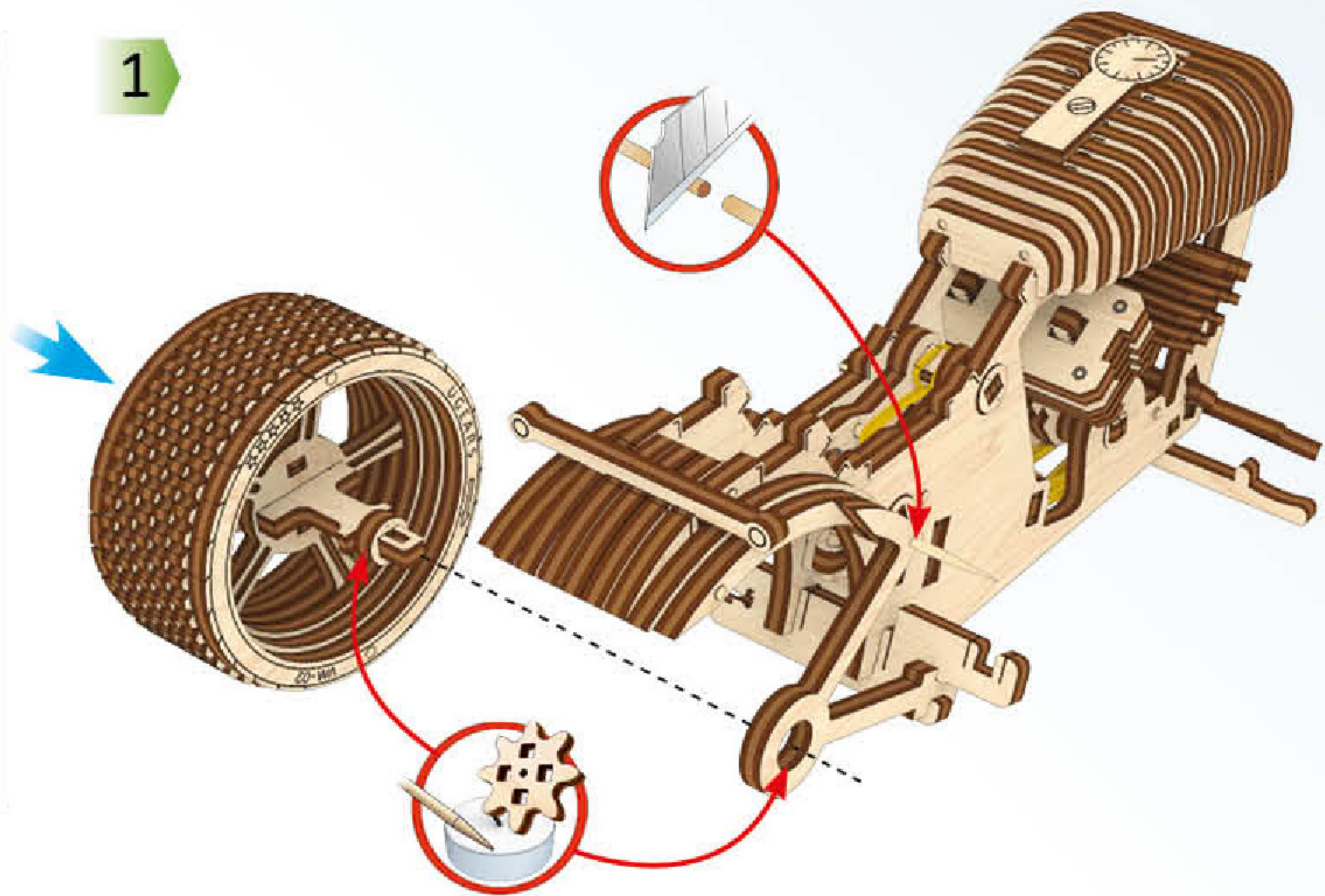
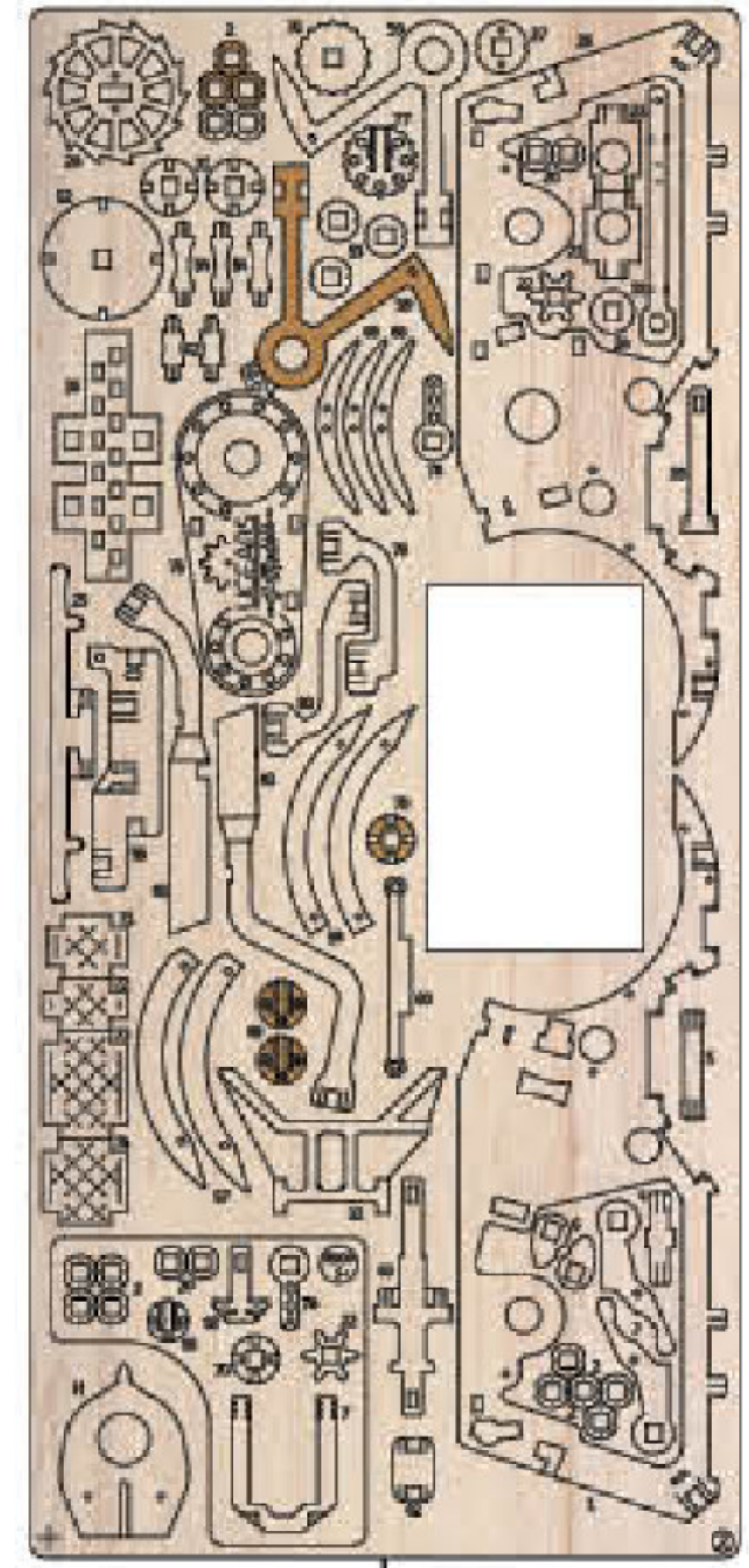

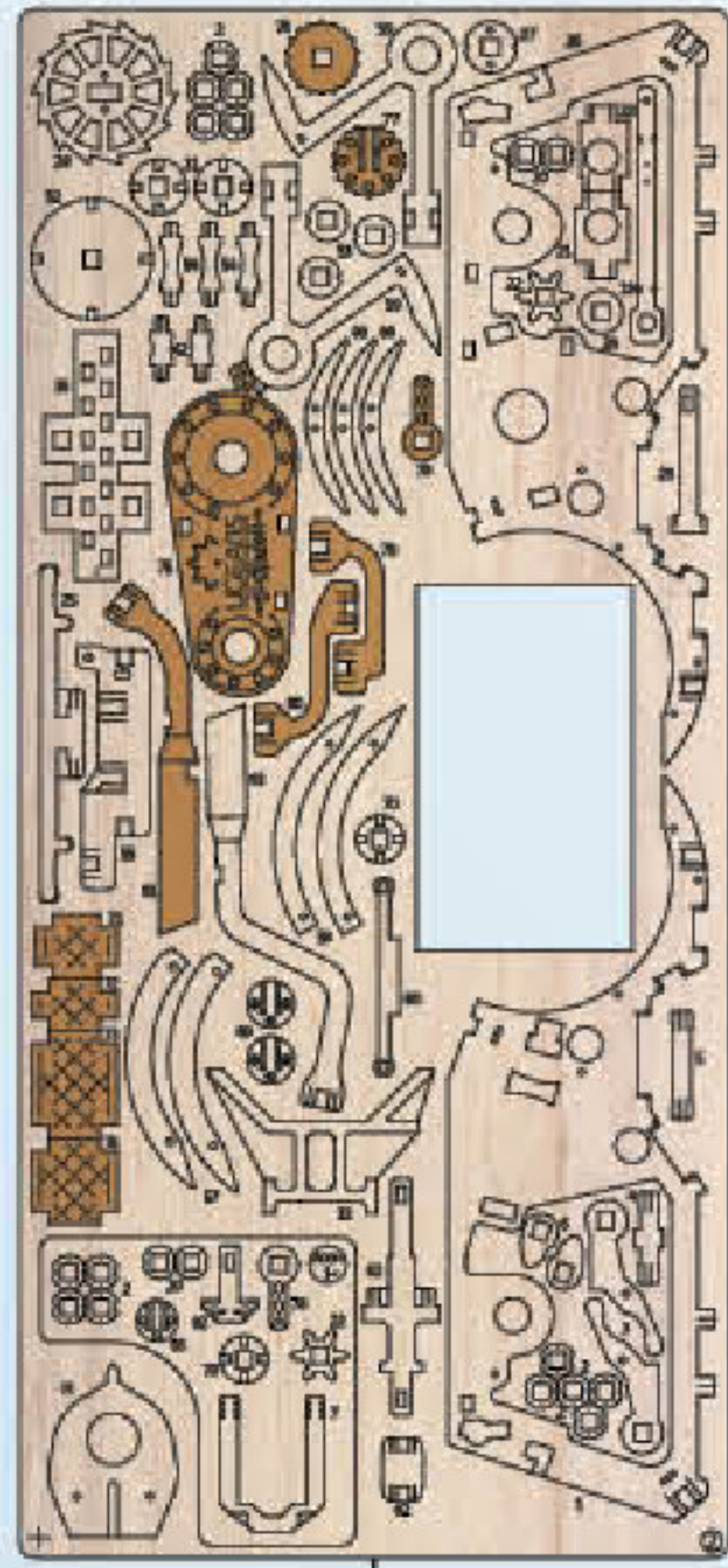

1

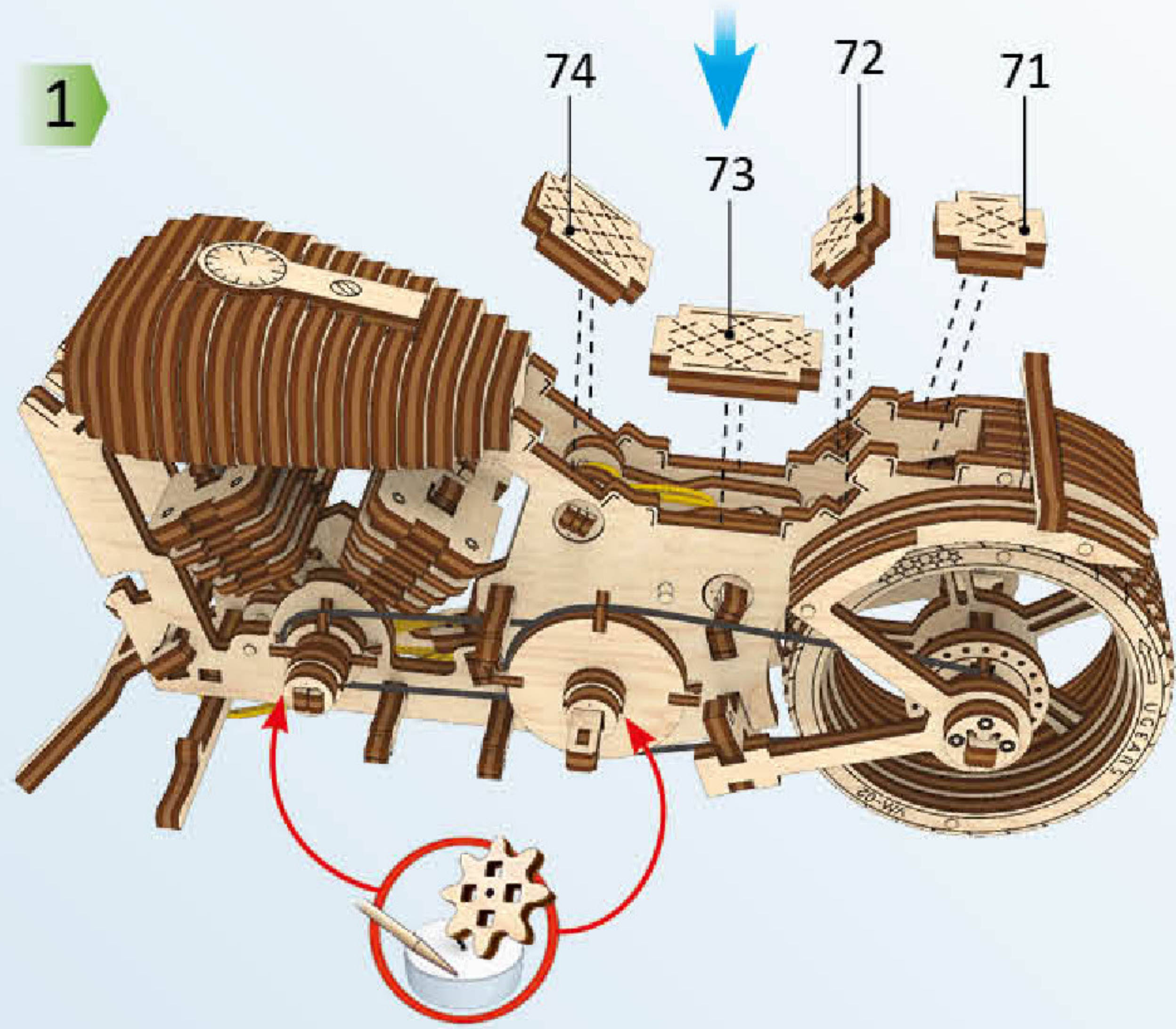

2

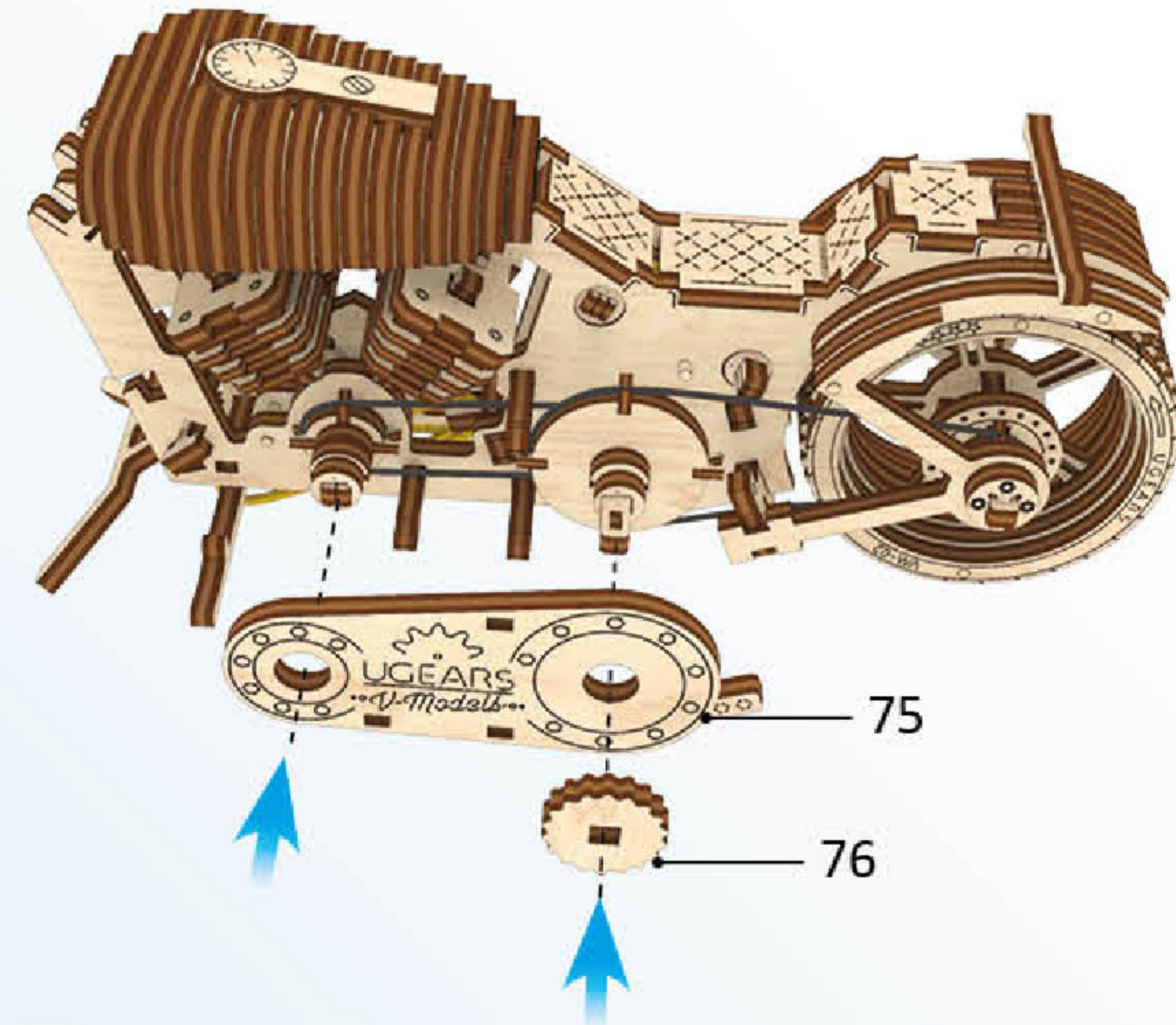

3

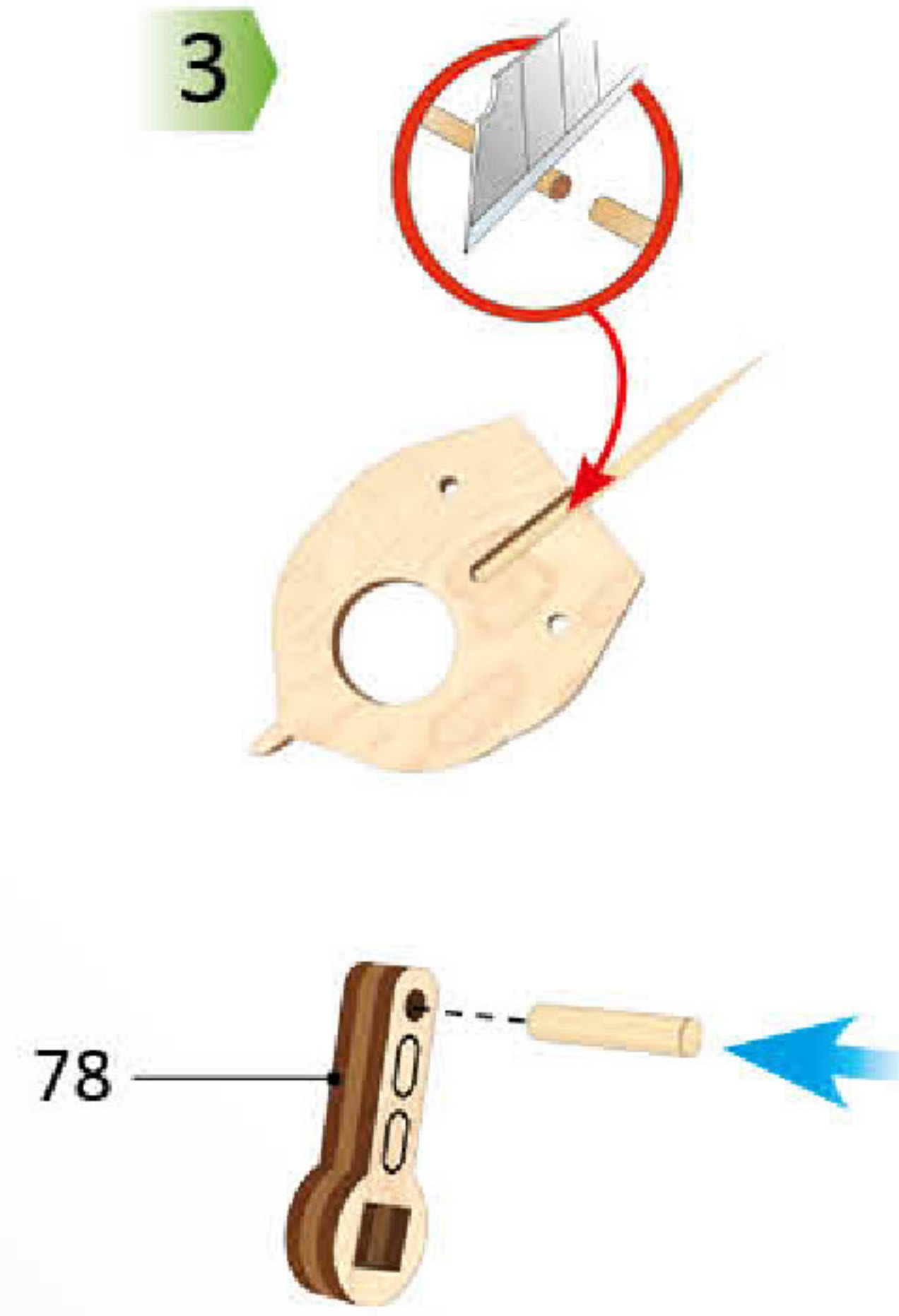

4

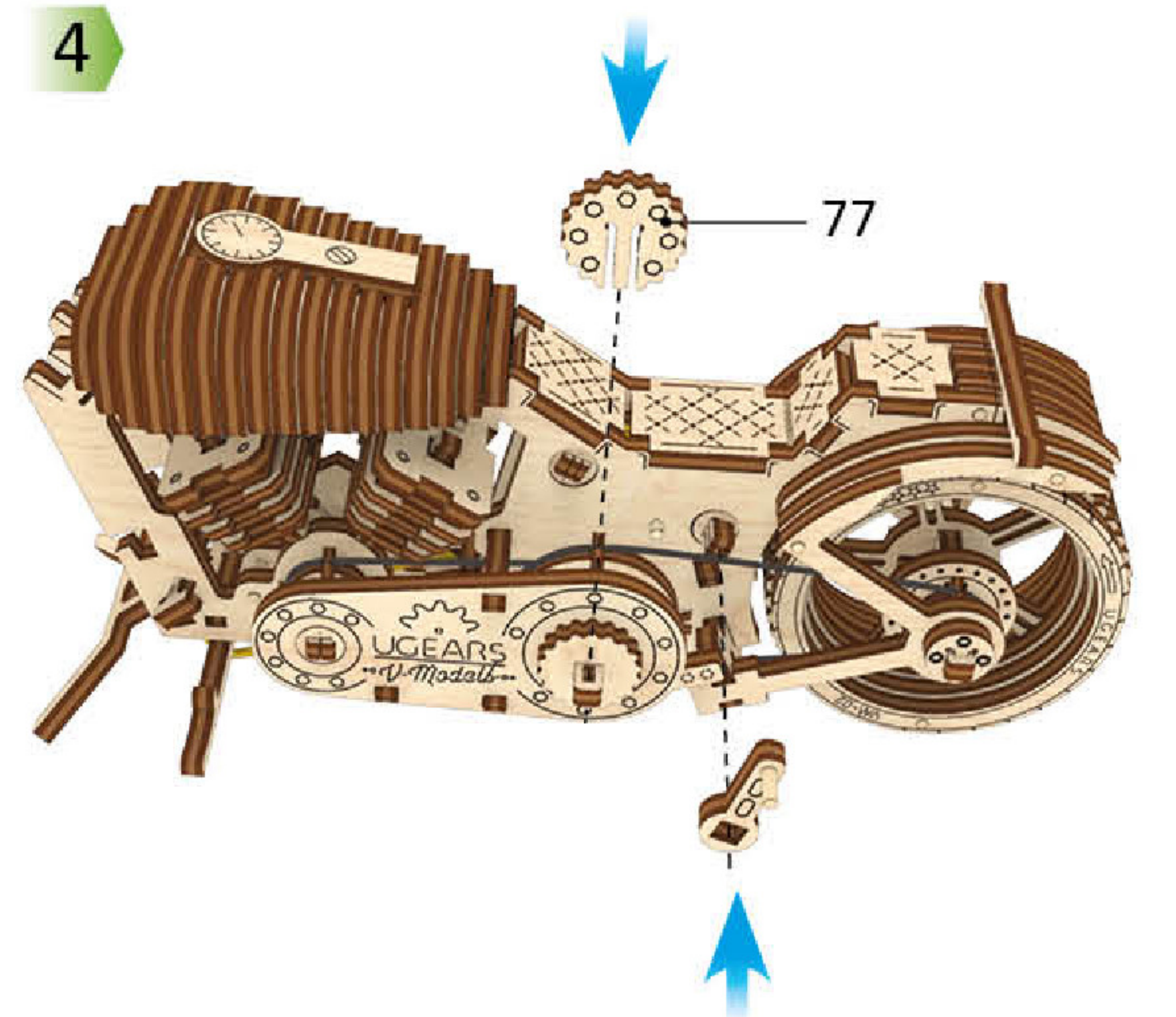

5

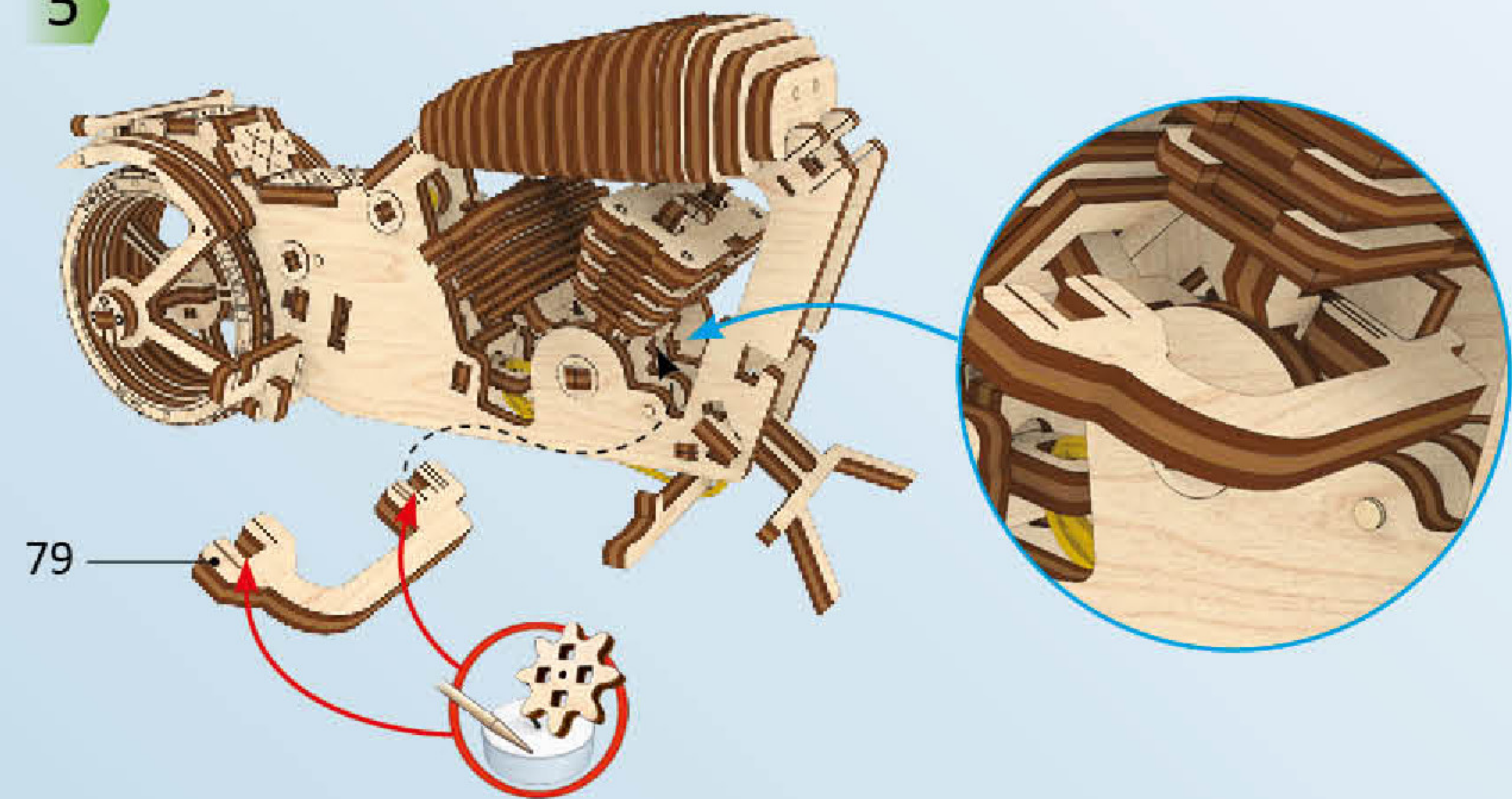

6

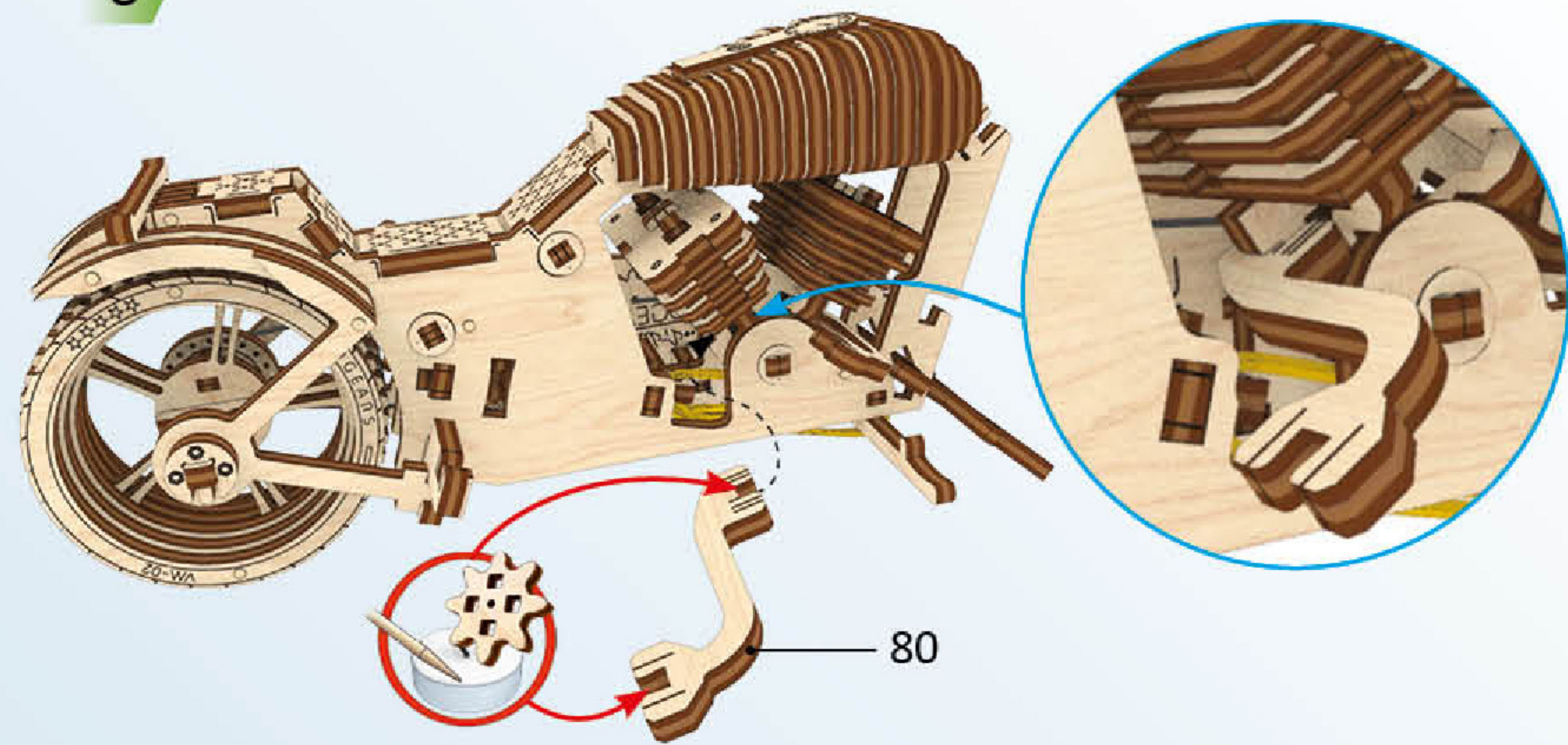

7

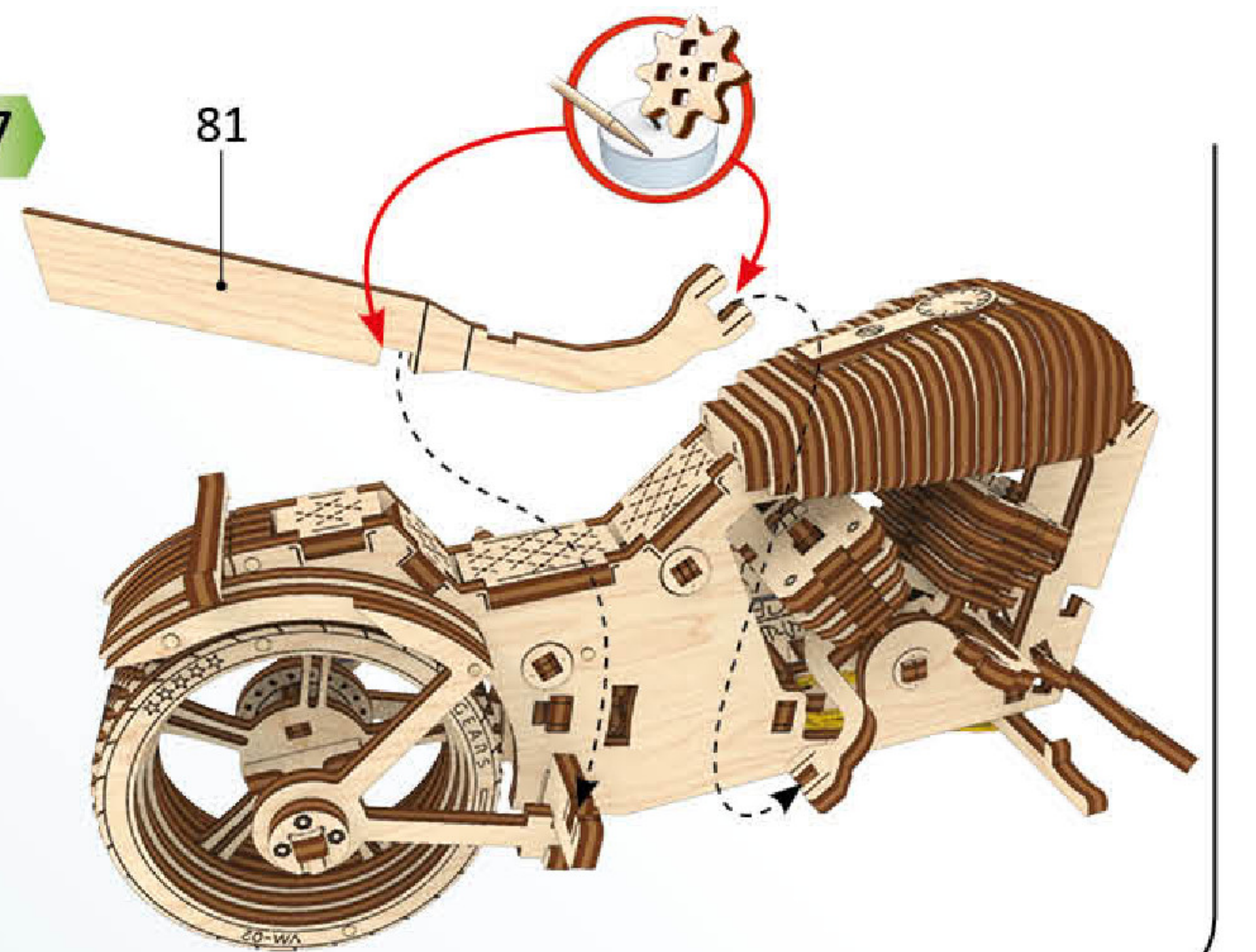

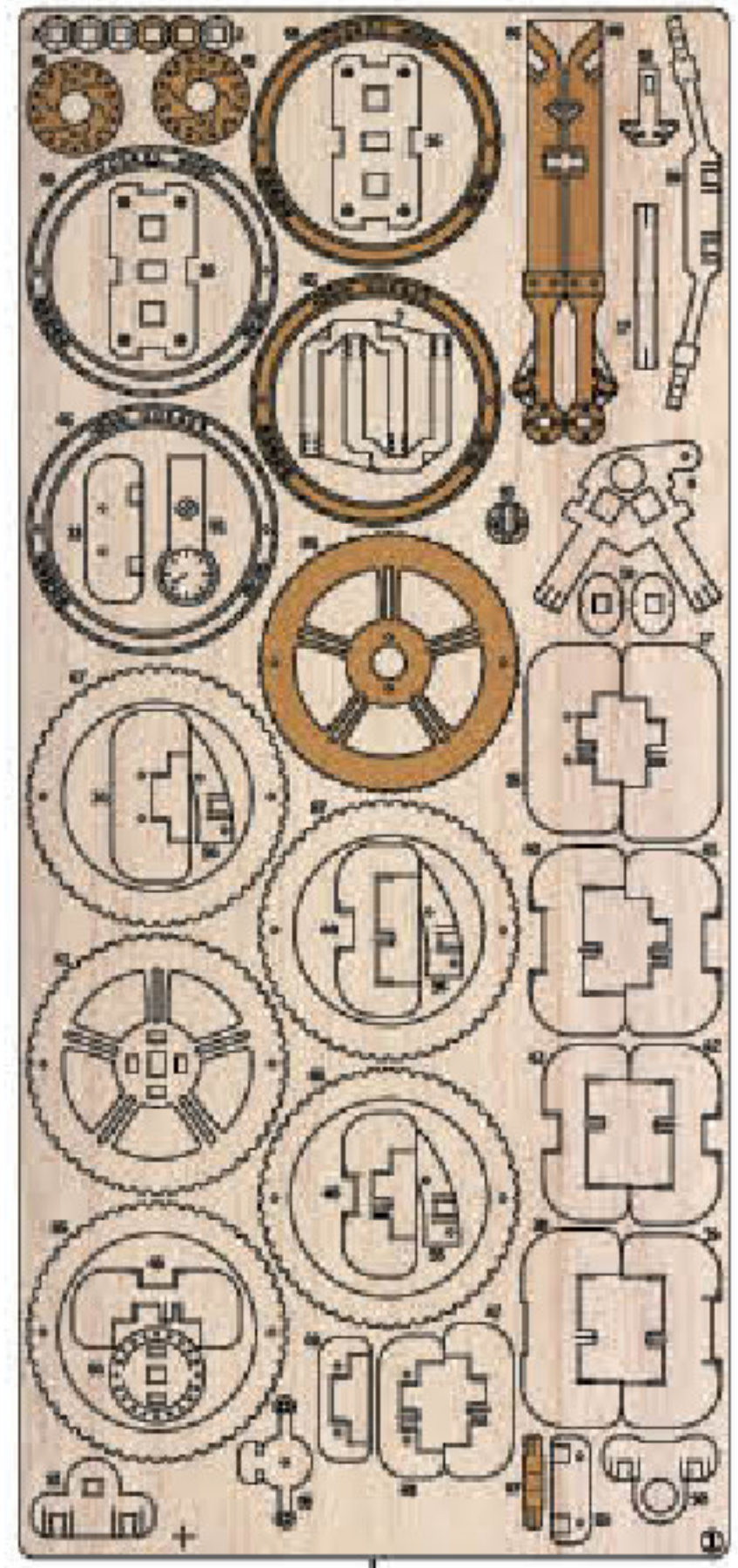

1

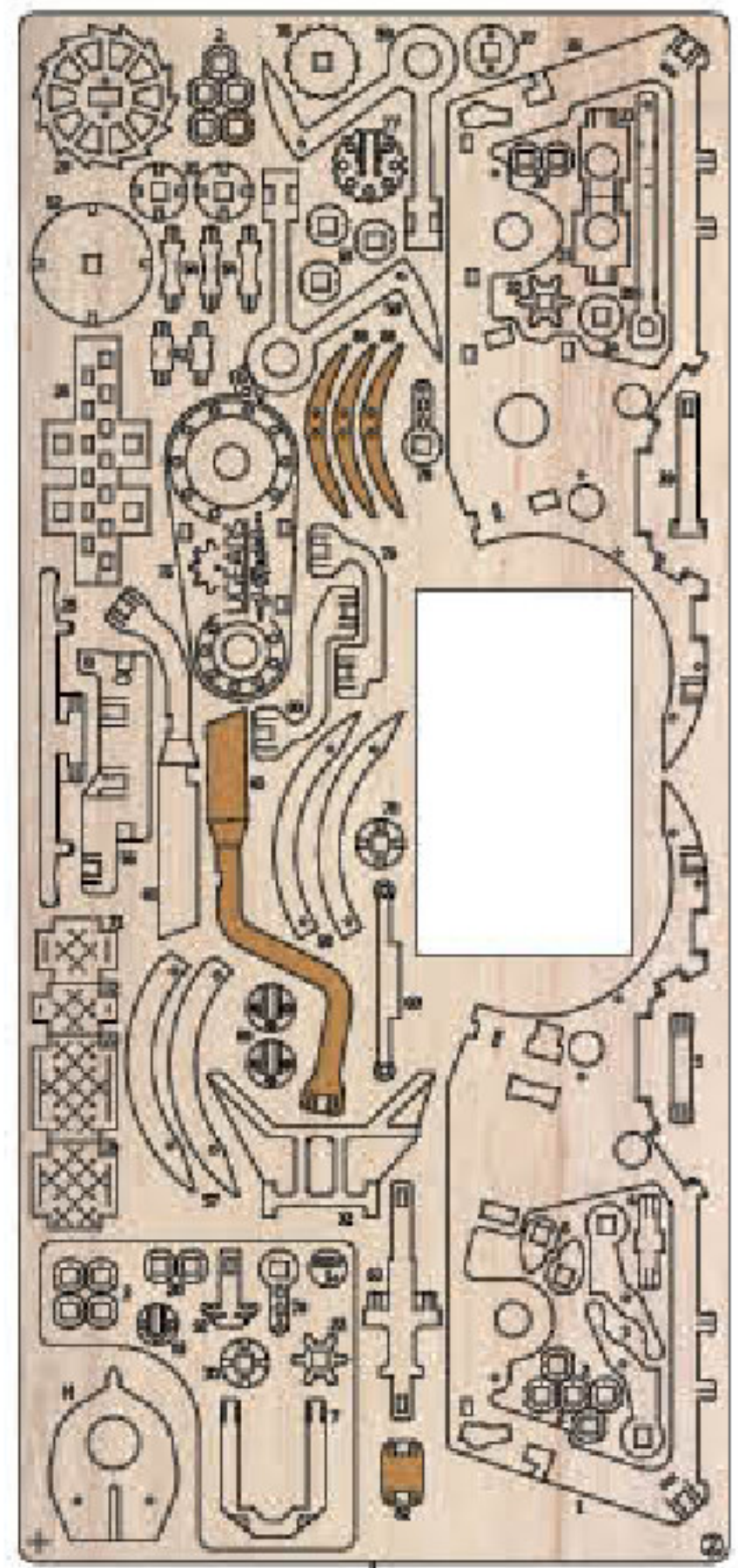

2

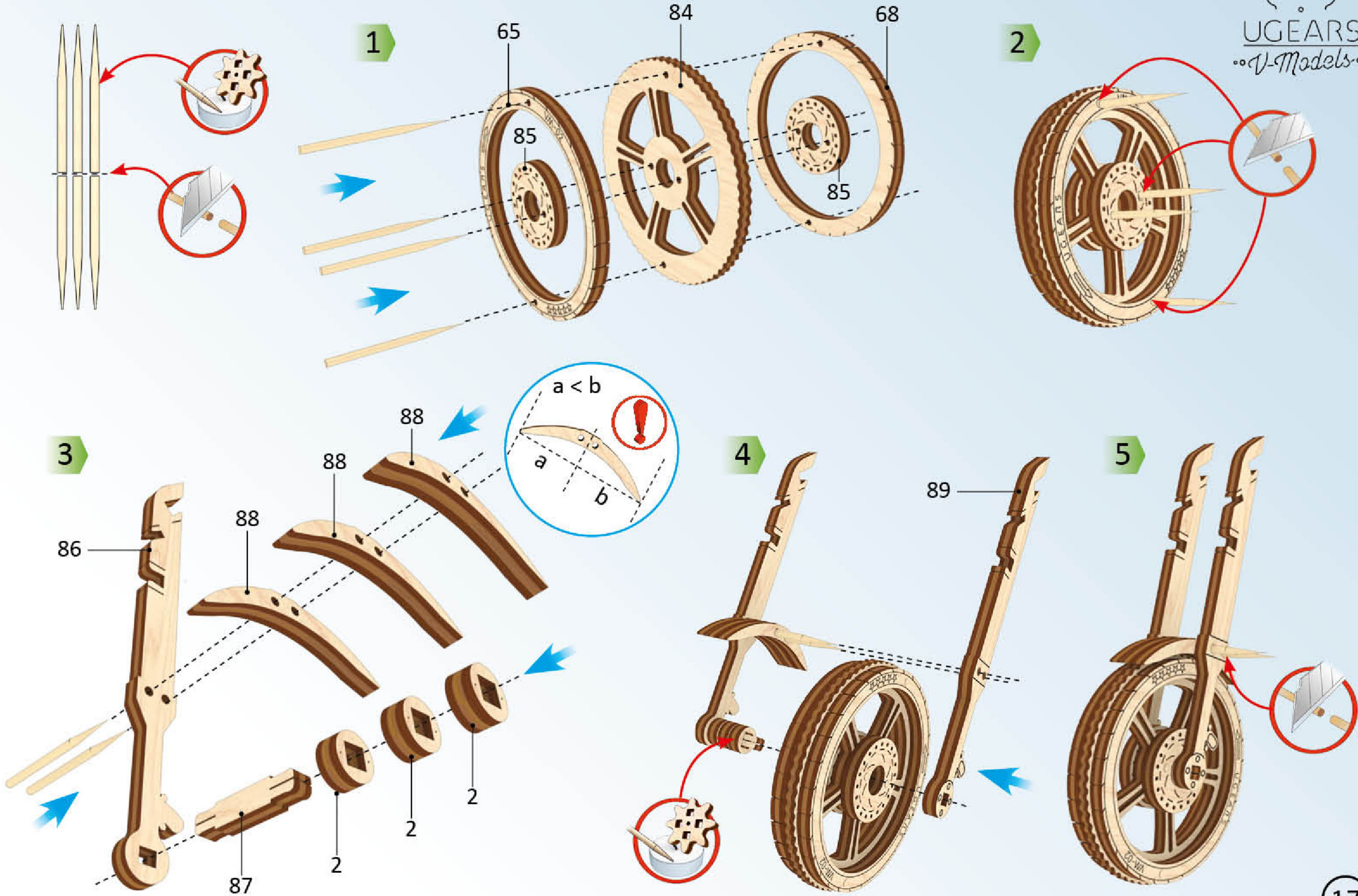
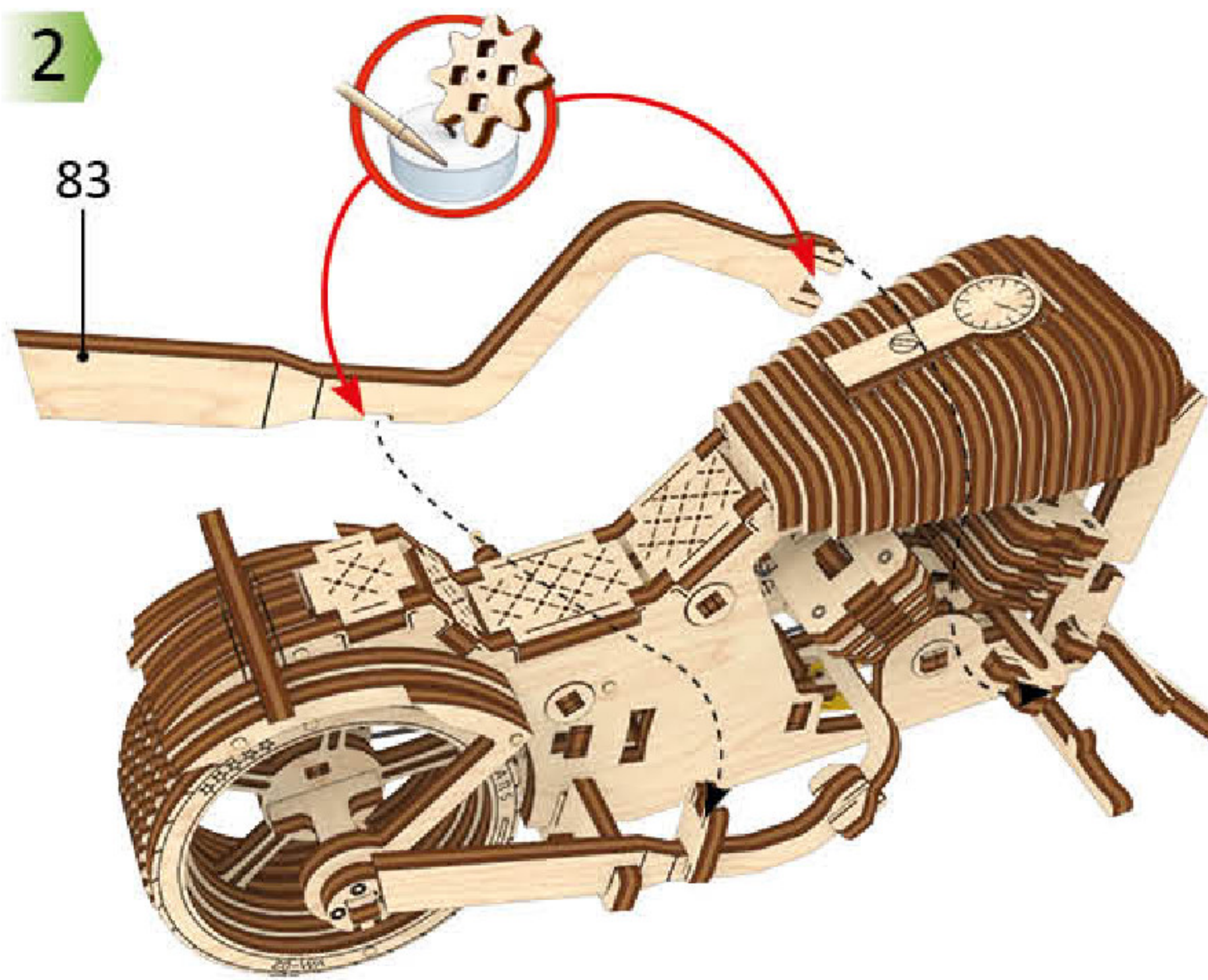
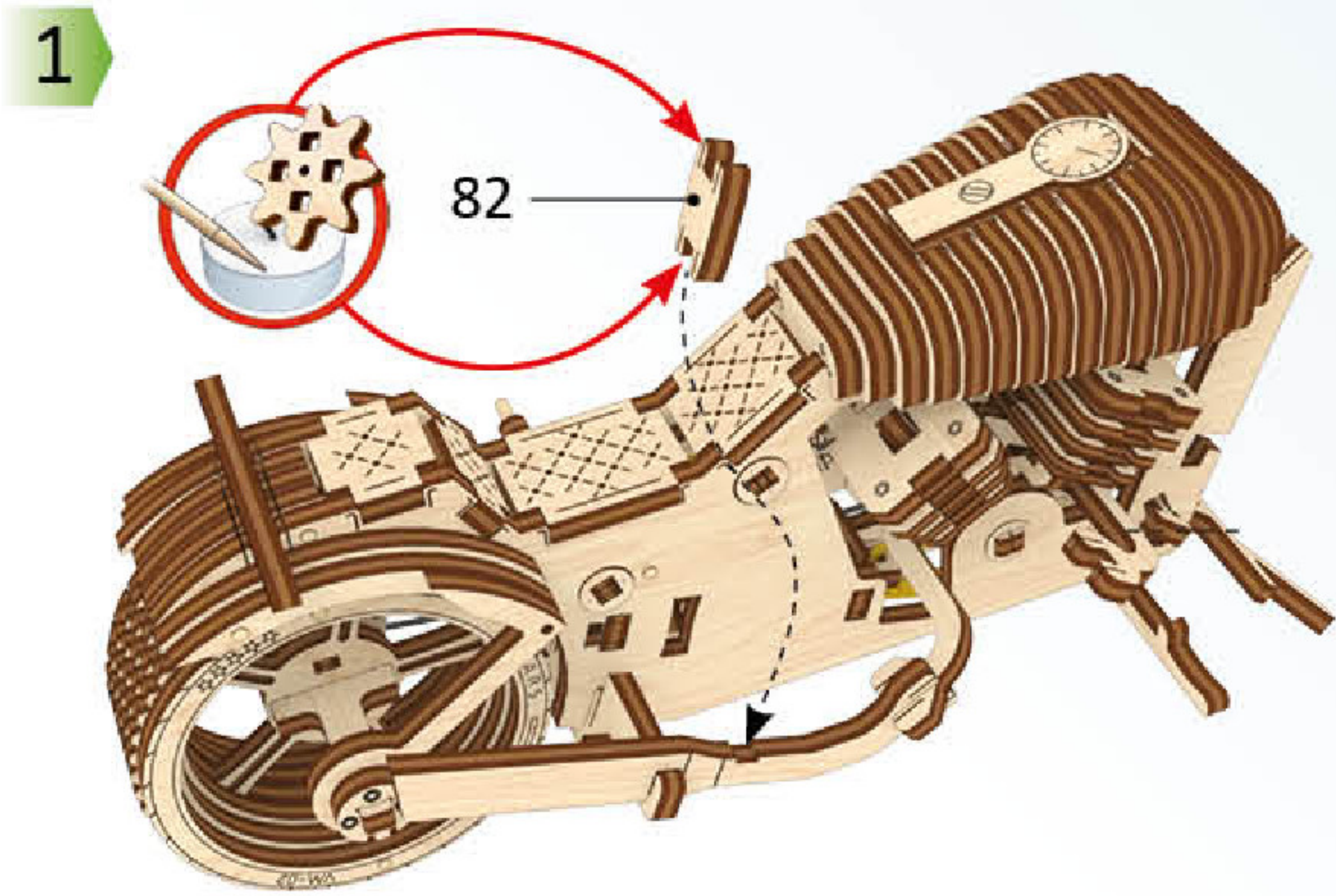

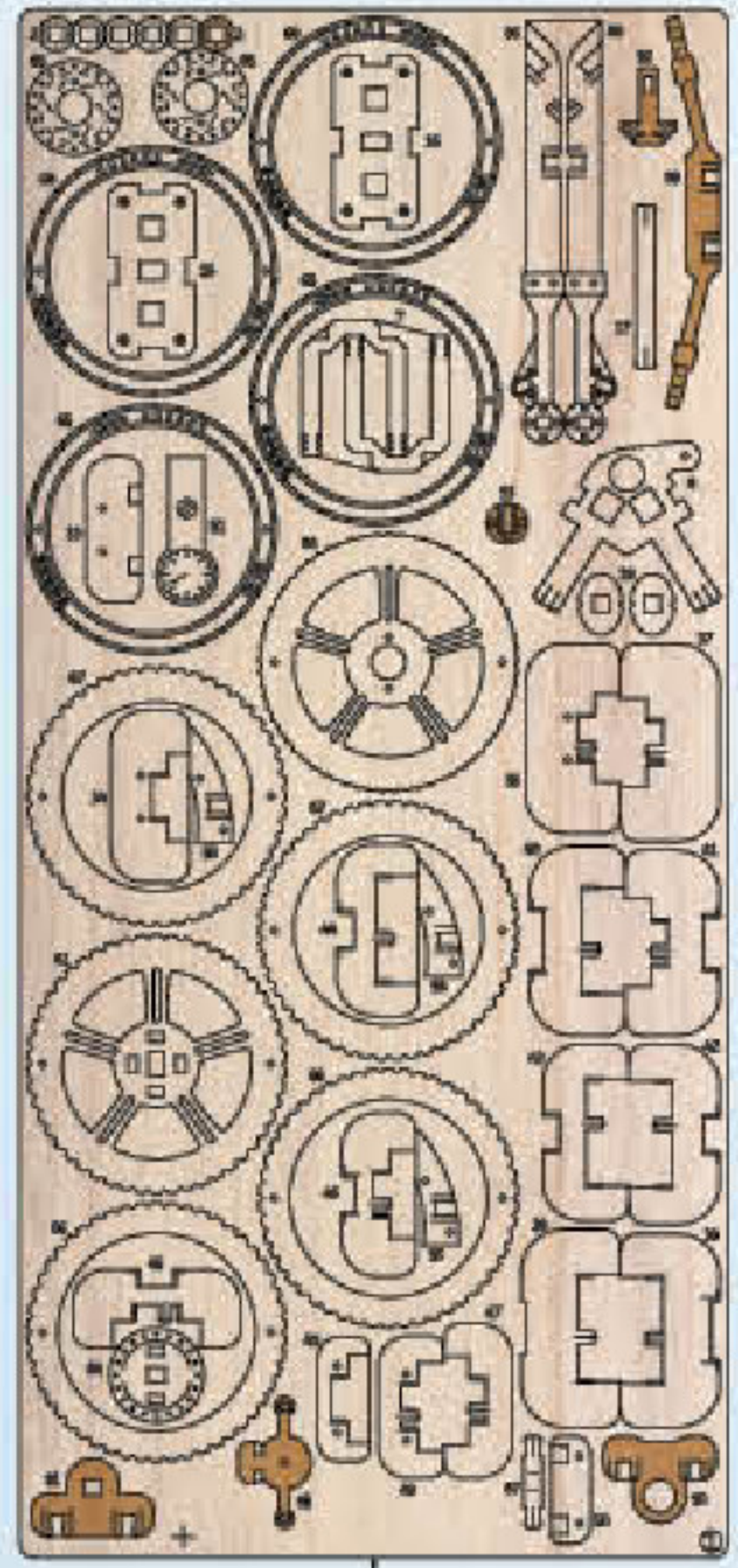

1

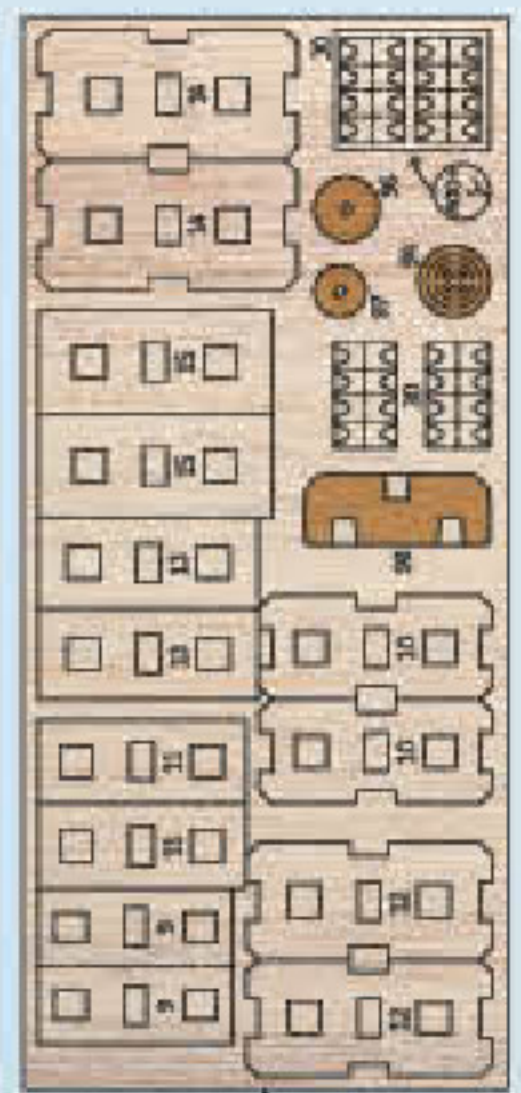

3

1

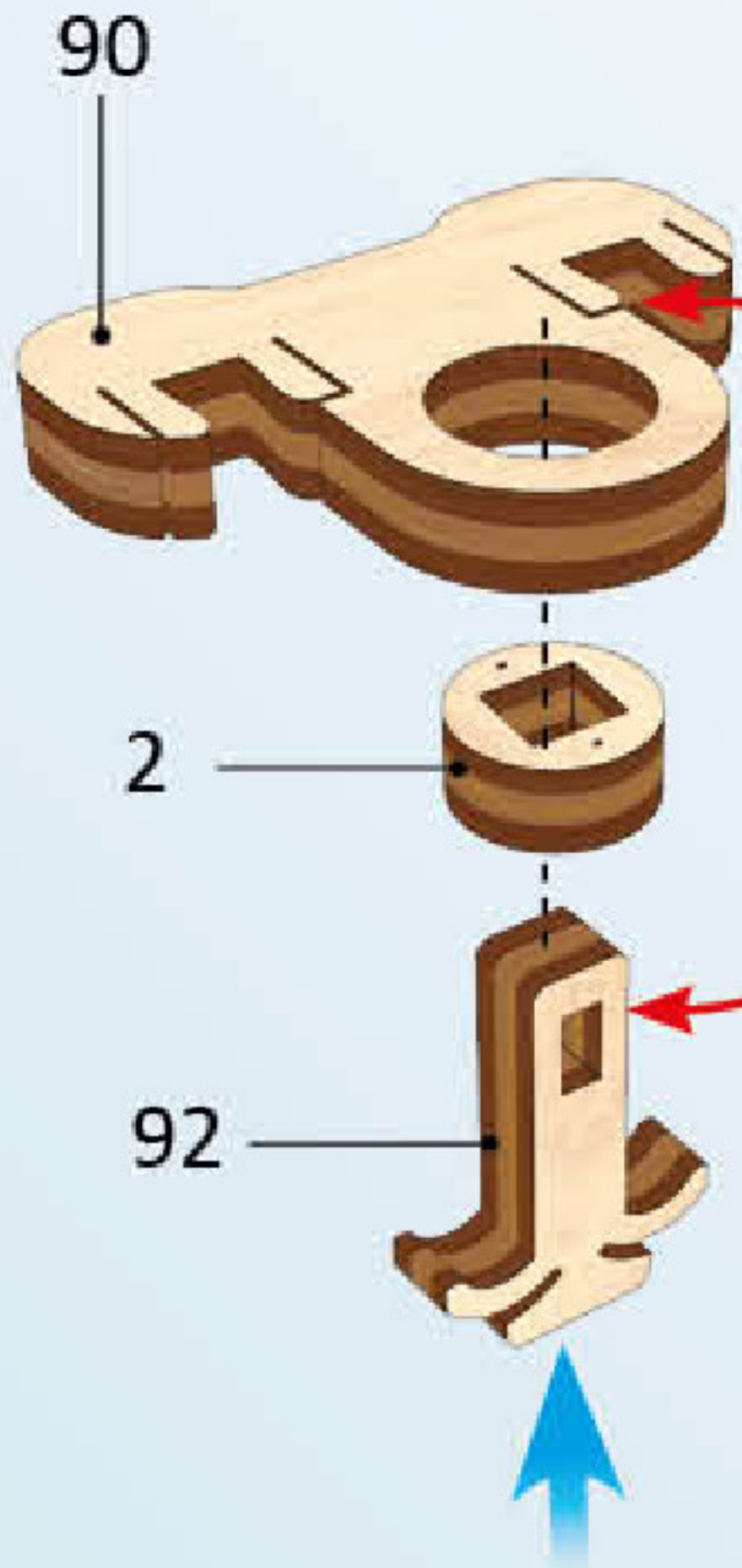

2

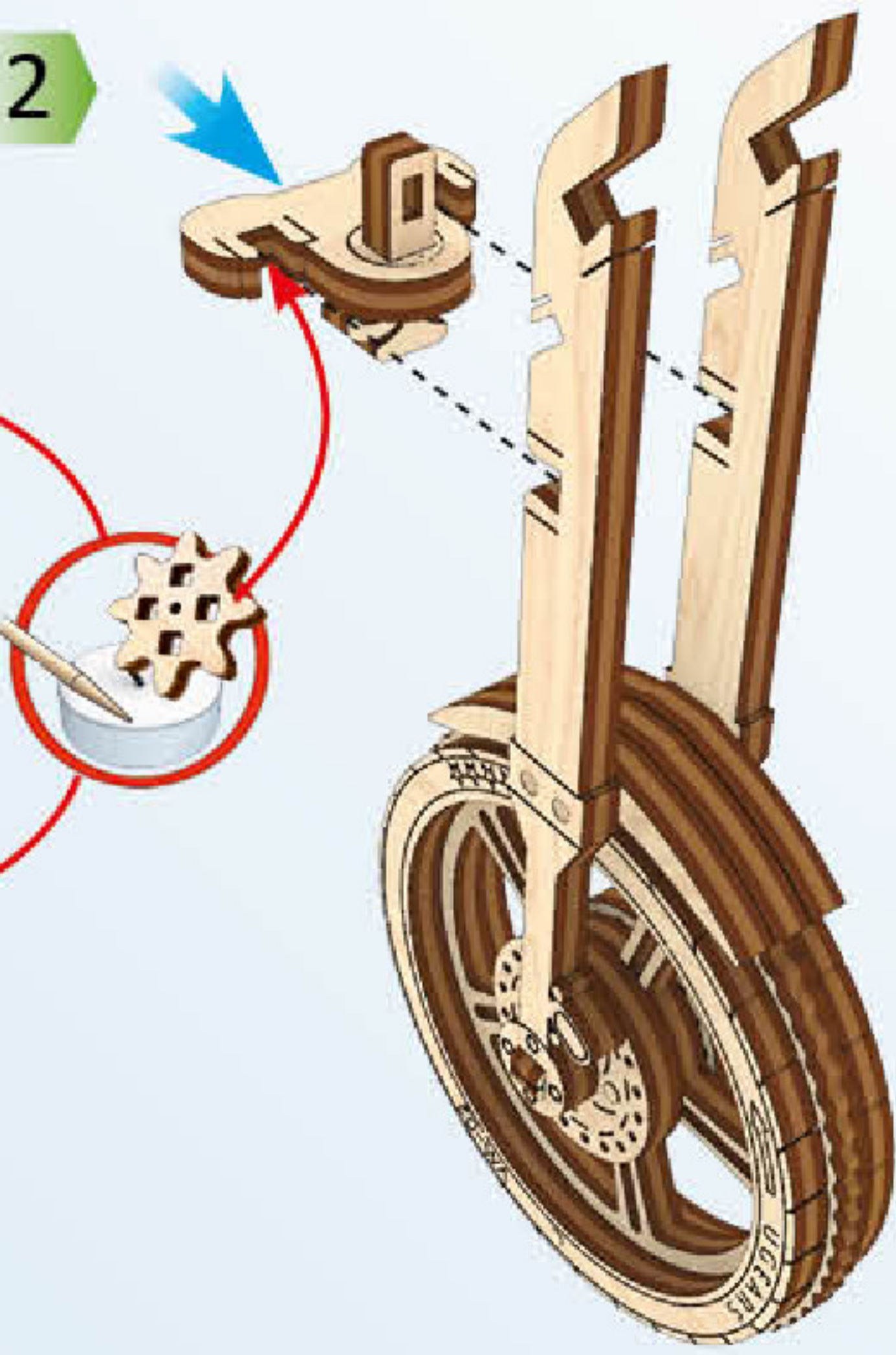

3

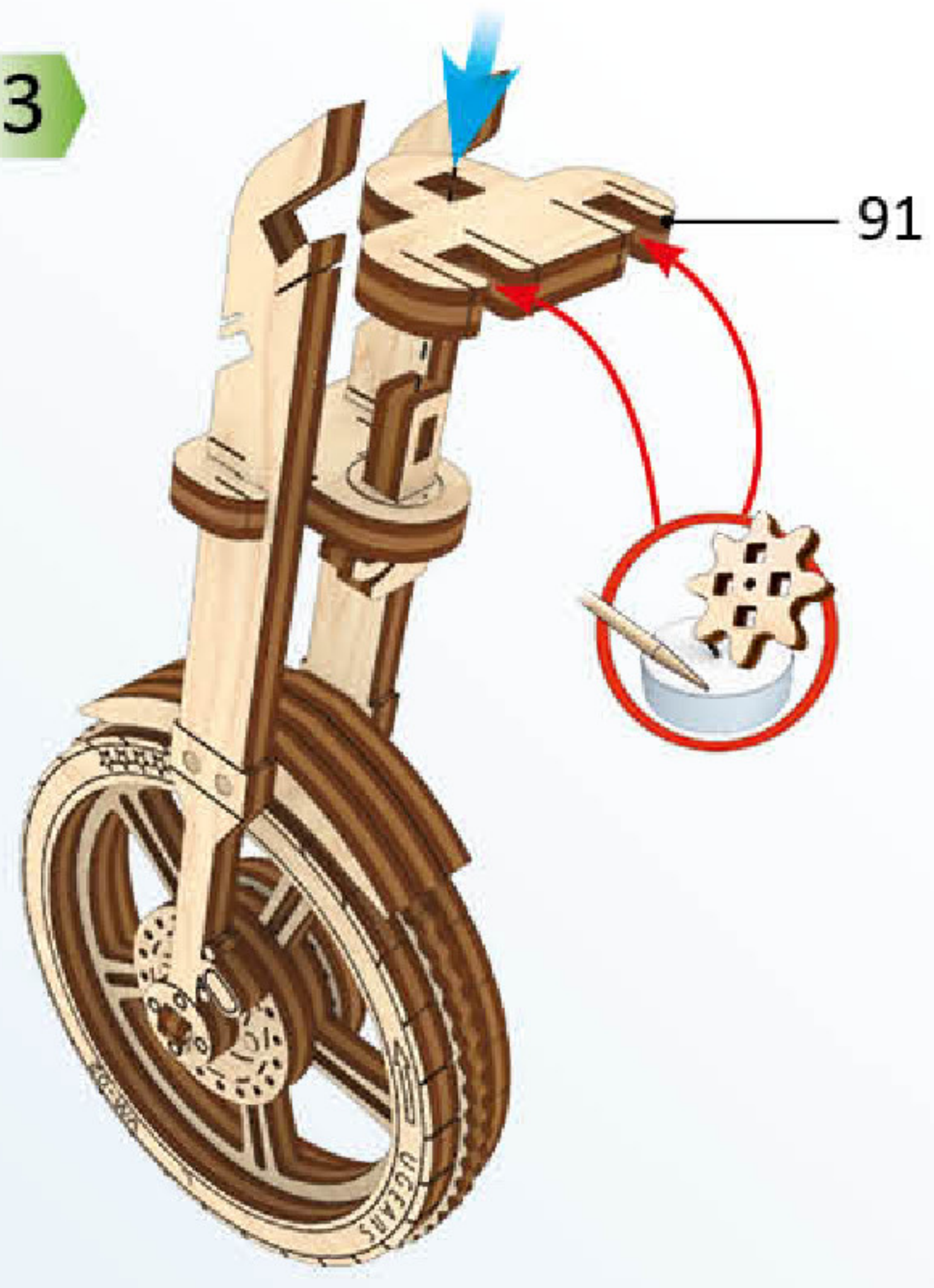

4

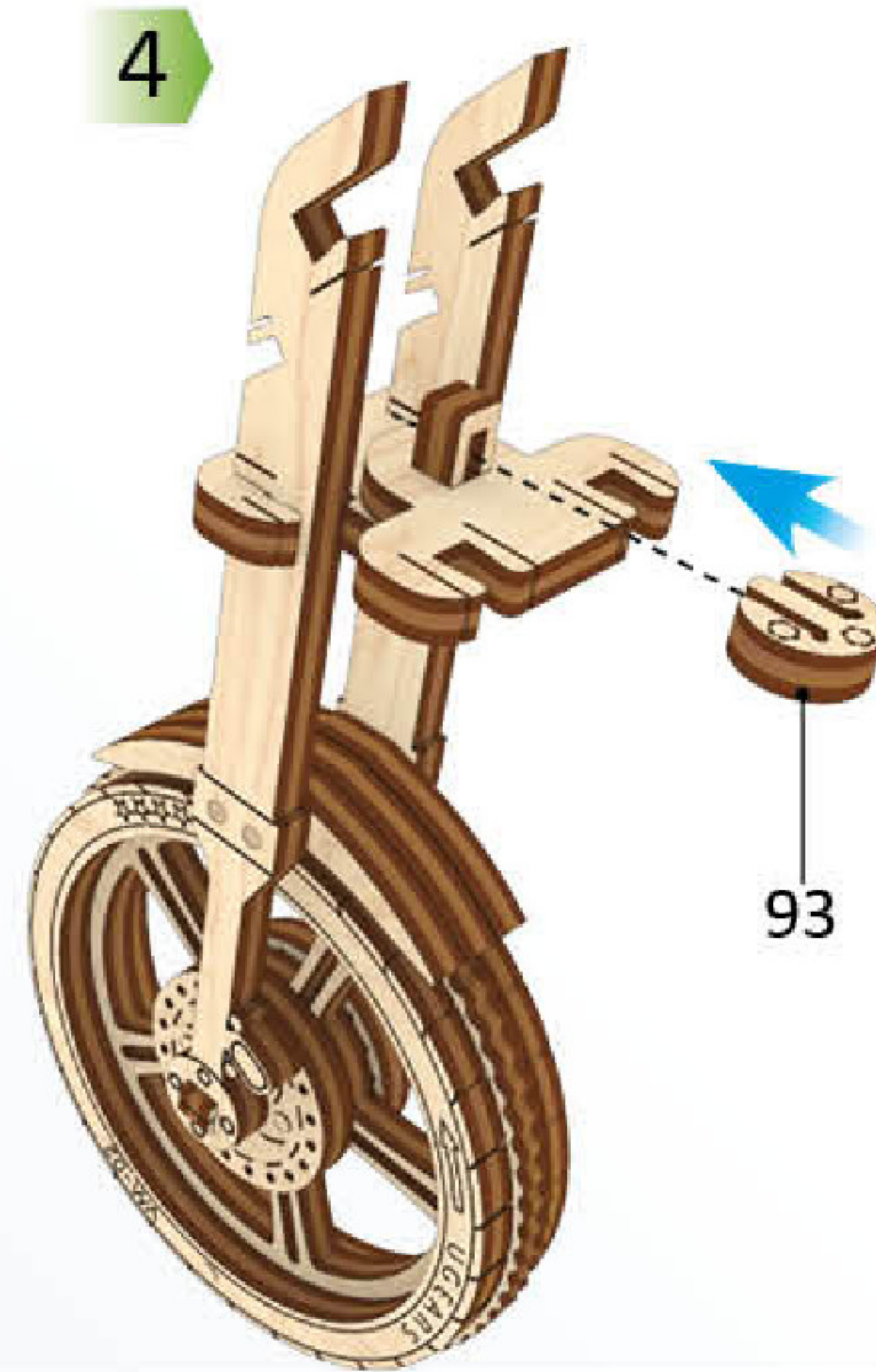

5

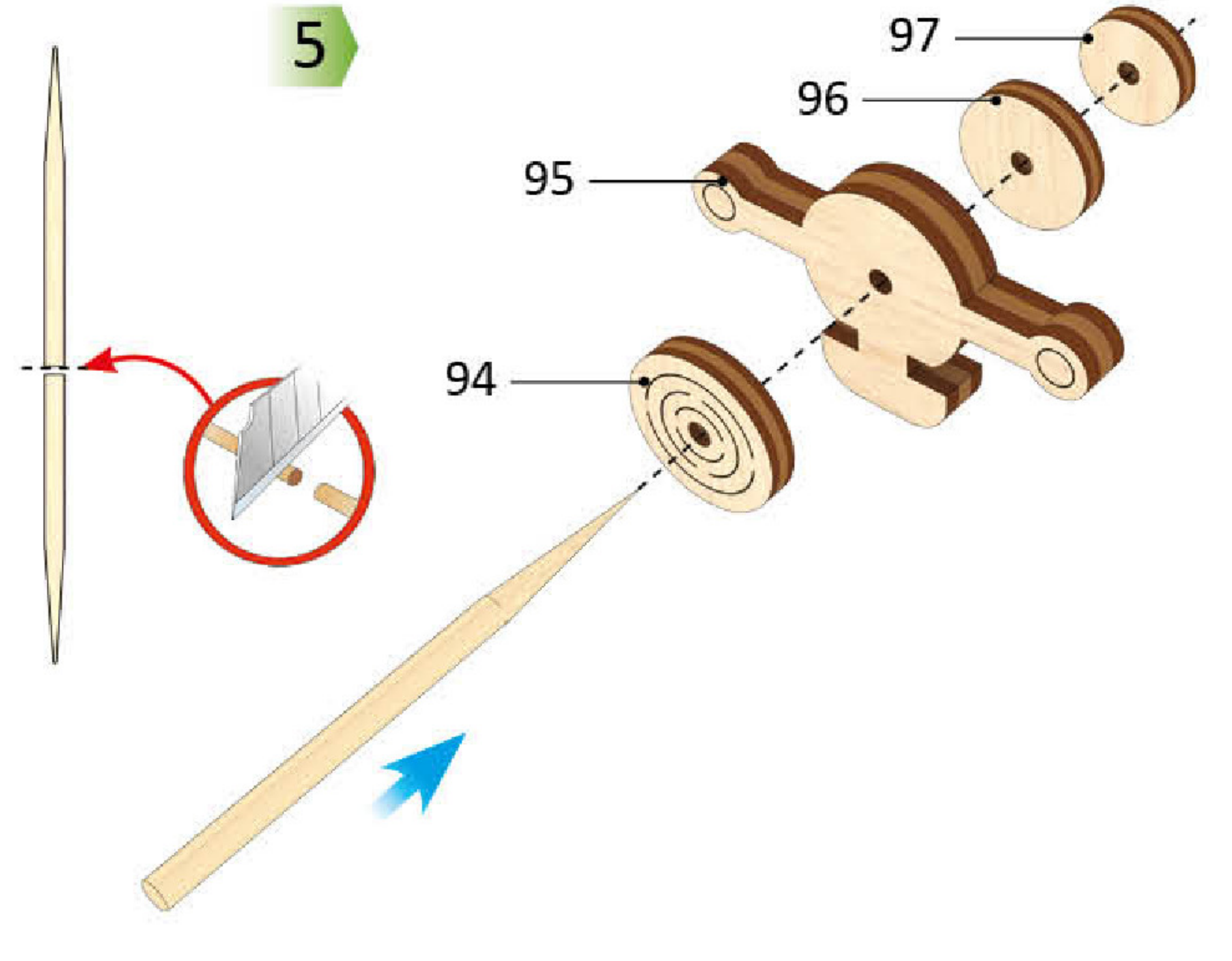

6



7

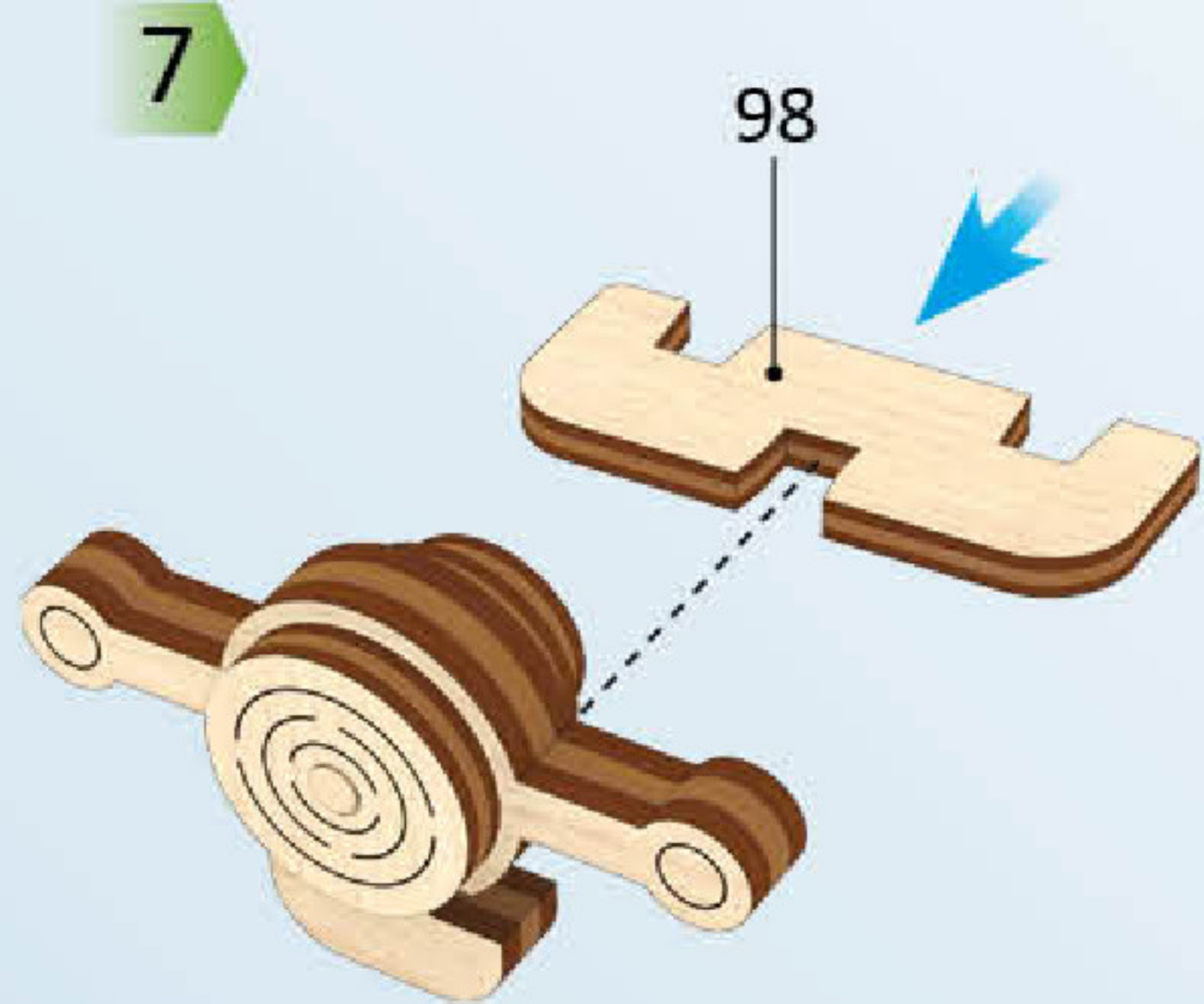

8

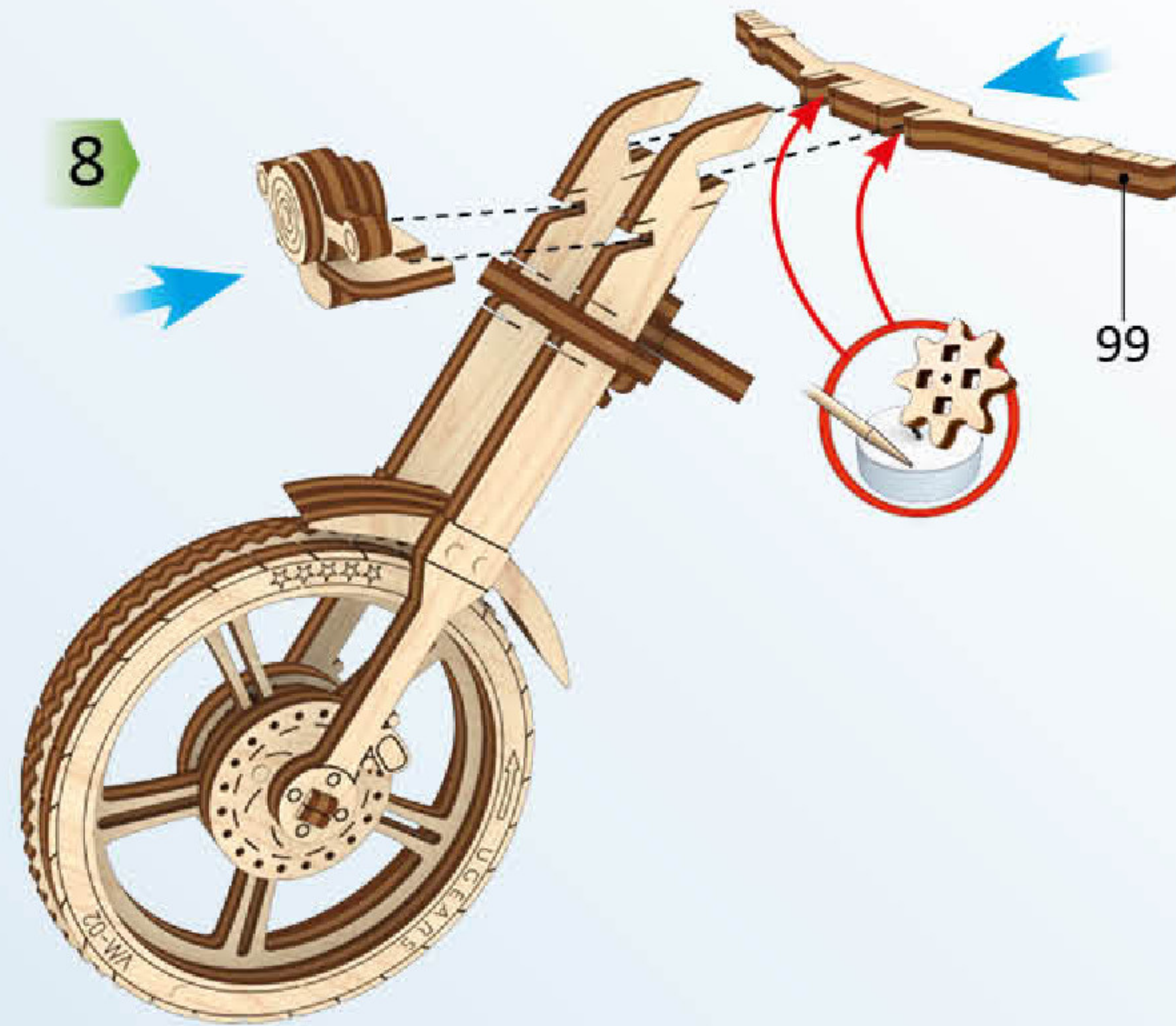

9

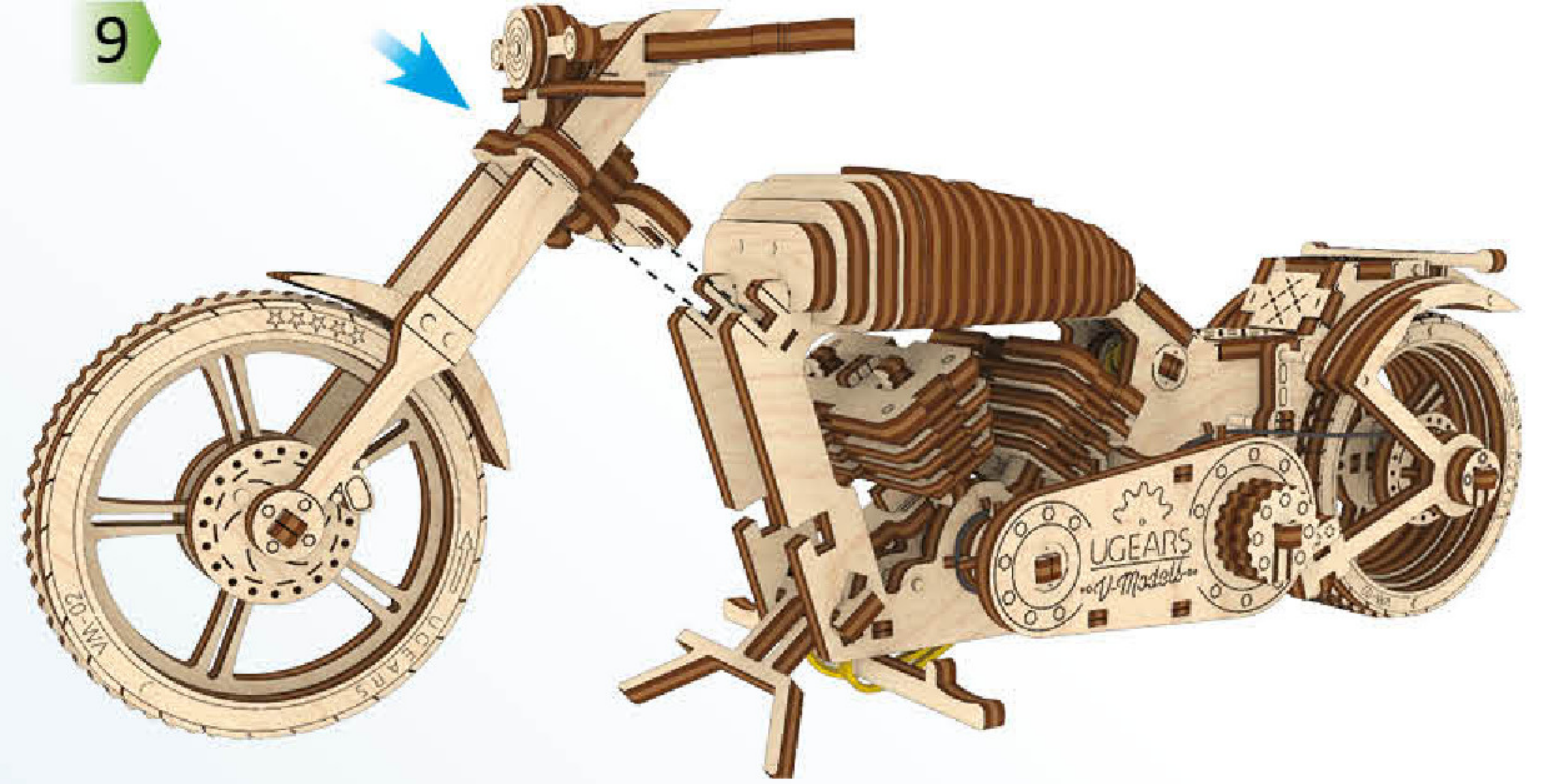

1

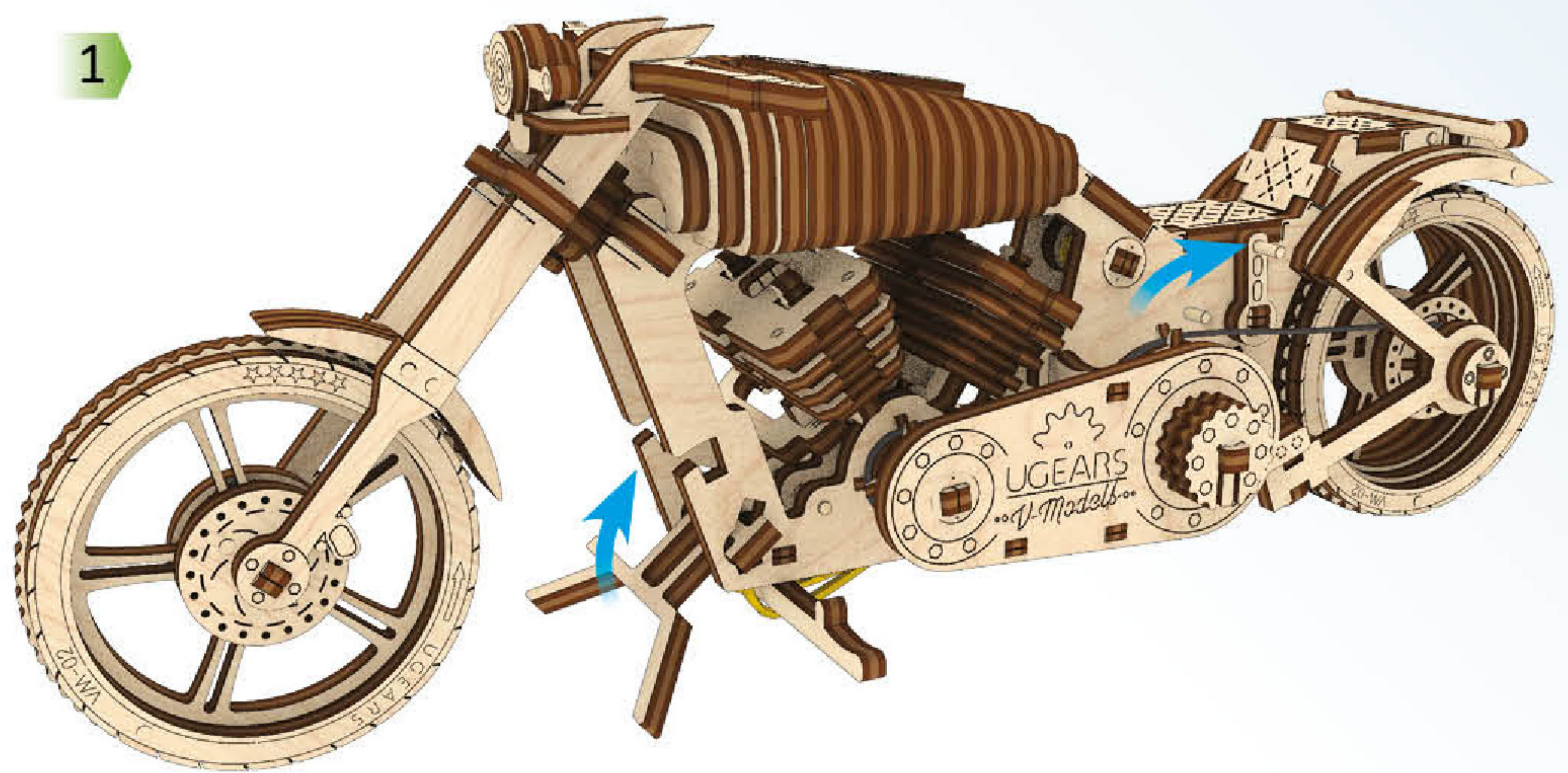

2

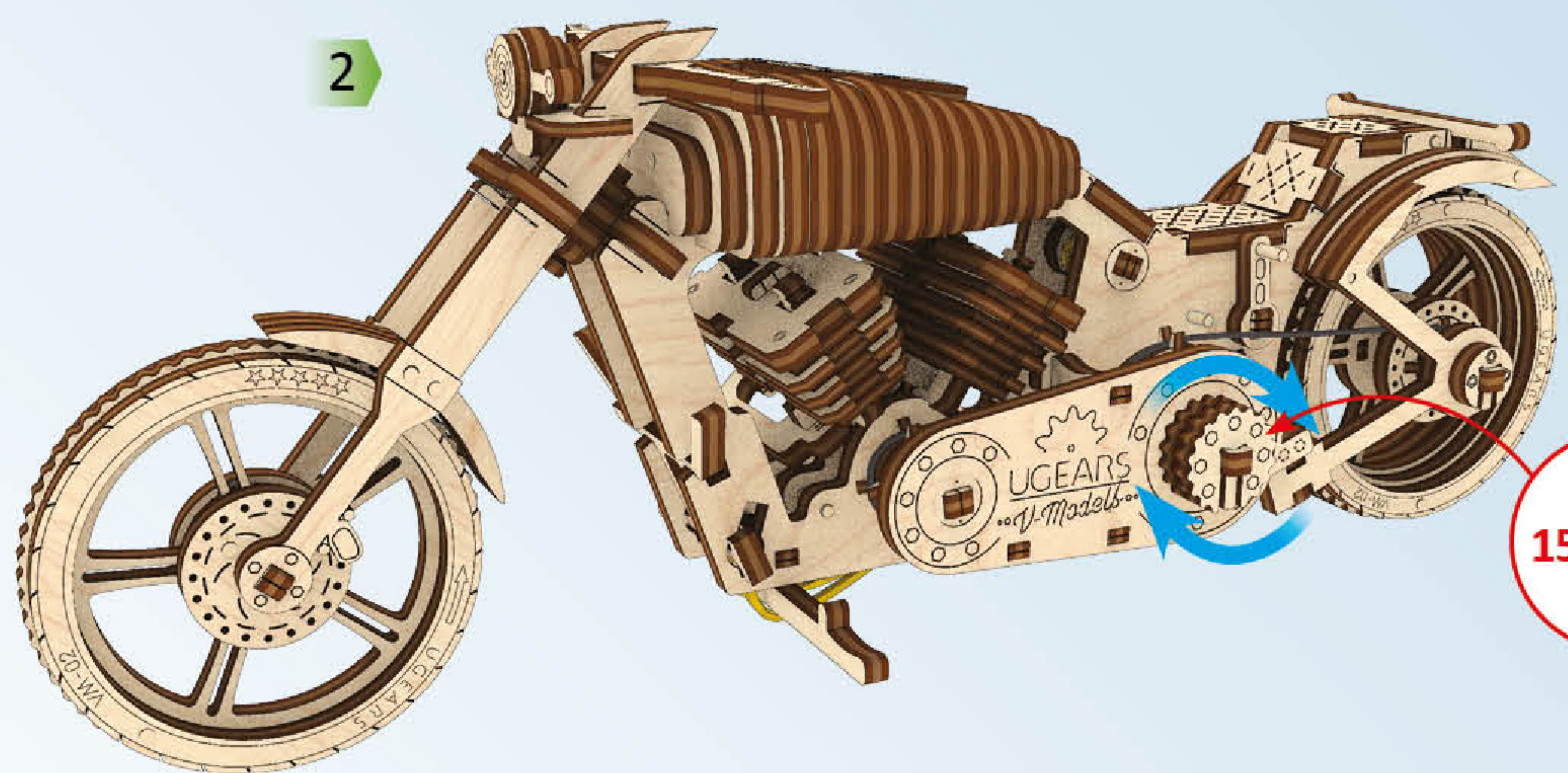

15 x 180°

3

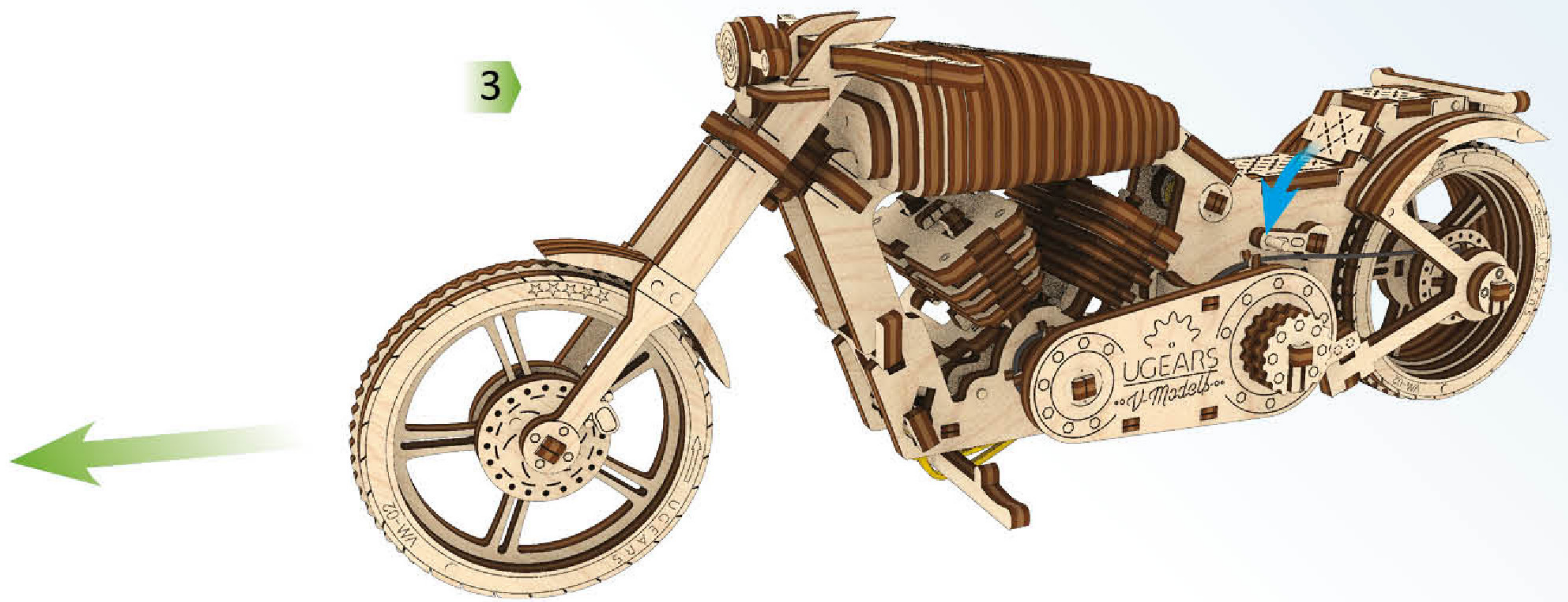



Assemble Me . Ride Me

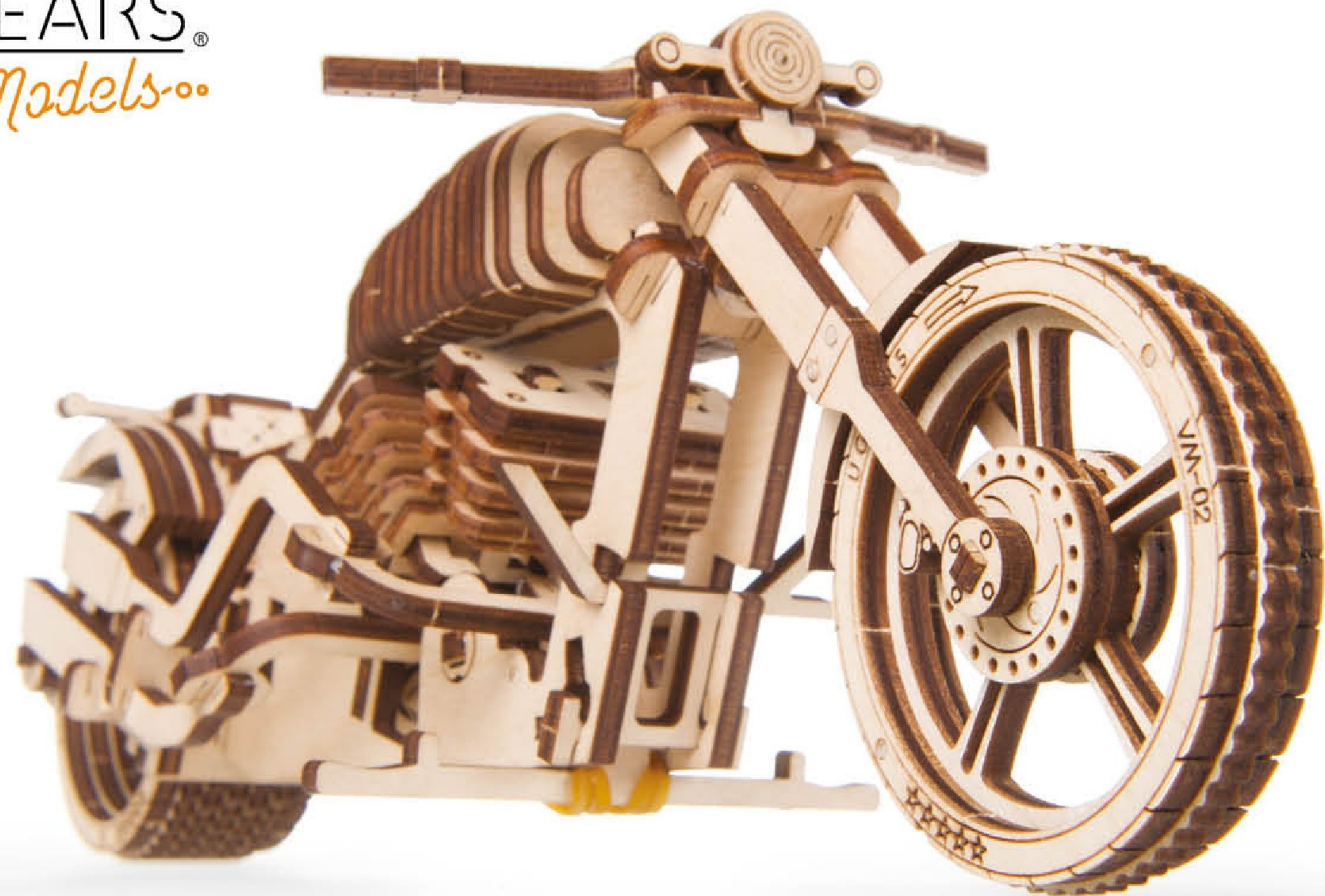

Bedankt voor de deelname aan deze reis met ons.

ugears-shop.nl

