



Find out MORE

# Assemble Me. Travel Me



UGEARS®  
V-Models

## "VM-Express trein"

DEU Modell «V-Express Dampflokomotive mit Tender»

FRA Modèle «Train à vapeur V-Express avec Tendeur»

POL Model «V-Express Pociąg Parowy z Węglarką»

SPA Modelo «Locomotora de Vapor V-Express»

ITA Modello «Treno a vapore V-Express»

TUR Model «V-Ekspres Buharlı Treni»

RUS Модель «Локомотив с тендером V-Экспресс»

KOR 고속 증기기관차 V

CHI V系-特快蒸汽火车带煤水车

## Handleiding in het Nederlands

DEU Aufbauanleitung. FRA Notice d'assemblage.

POL Instrukcja montażu. SPA Instrucciones de montaje.

ITA Istruzioni di montaggio. TUR Kurulum talimatı.

RUS Инструкция по сборке. KOR 조립 설명서.

CHI 装配说明书



NATURAL

Made from wood materials



NO GLUE CONNECTION

Assembling without glue and chemicals



SELF ASSEMBLY

Details are already cut and ready to assemble



MECHANICAL

The models produce motion



EDUCATIONAL

Perfect for family projects through hands-on STEM learning

## NED

### Bouwinstructies.

Verwijder de onderdelen van de borden zoals hieronder is geïllustreerd. Pas op dat de onderdelen niet breken. Wanneer het niet loskomt, gebruik dan voorzichtig een mesje. Dit model bouwt u zelf zonder gebruik te maken van lijm. Wanneer onderdelen moeilijk te plaatsen zijn. Smeer deze dan in met een kaars. Om frictie te voorkomen behandelt u ook alle beweegbare onderdelen met een kaars.

### Waarschuwing!



Gebruik geen kaars die brand!



Opgepast, de spieën zijn scherp!

## Pictogrammen.



Smeer het onderdeel in met kaarsvet.



Opgelet! Controleer de goede positie.



Controleer het mechanisme op een soepele en goede beweging. Breng het mechanisme in beweging om de onderdelen in positie te krijgen.



Het onderdeel moet gemakkelijk te draaien zijn.



Plaats symmetrisch.



Herhaal de stap maar dan gespiegeld.



Schuur om de bramen te verwijderen.



Breek of snij het onderdeel uit.



UGEARS  
V-Models



Reserveonderdelen.

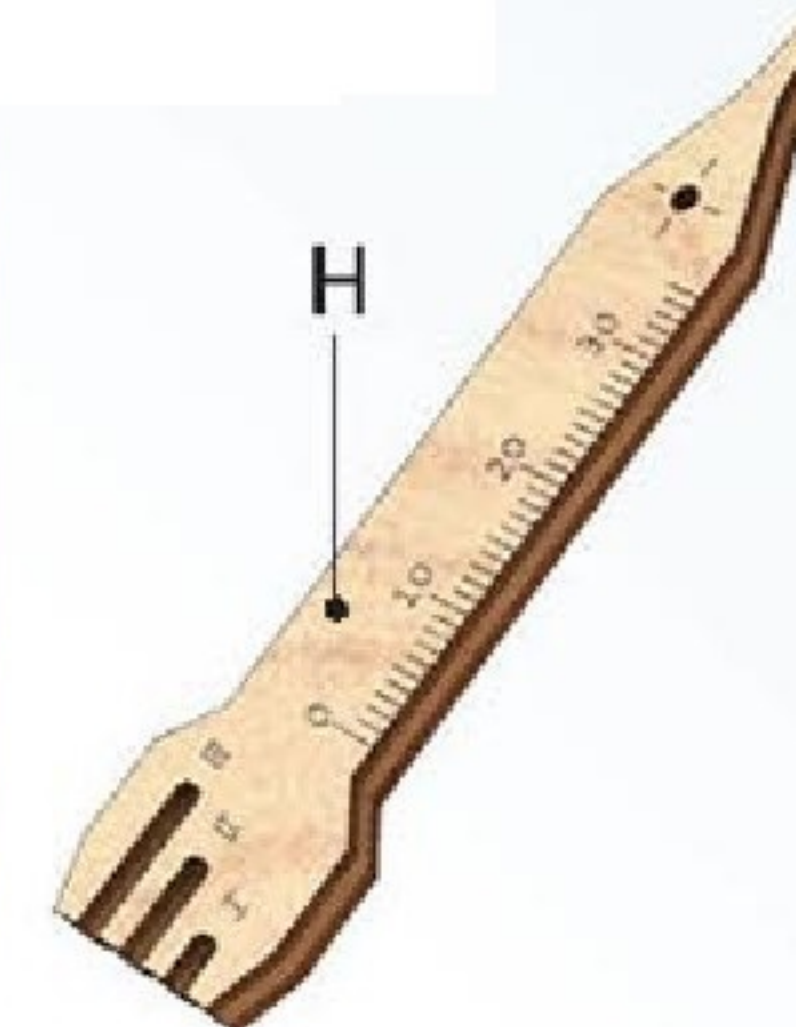
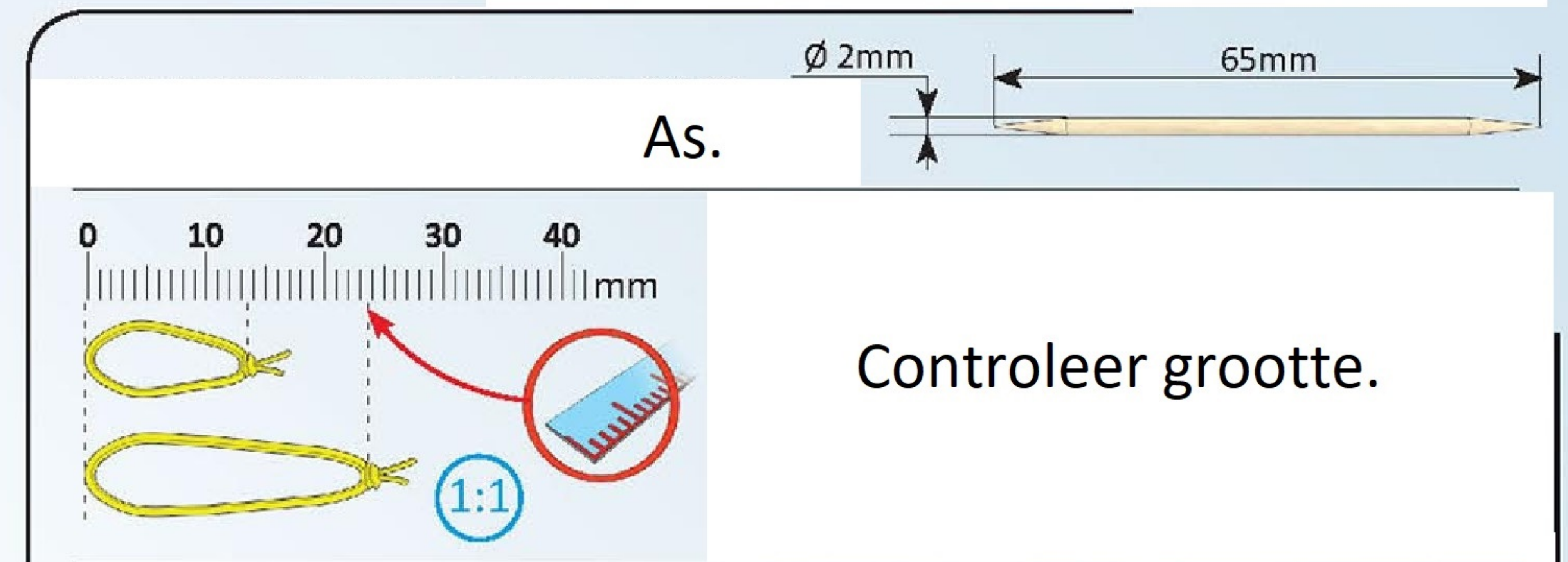

Dit is geen onderdeel. Het is een gereedschap voor meting en montage. Leder model heeft z'n eigen gereedschap.

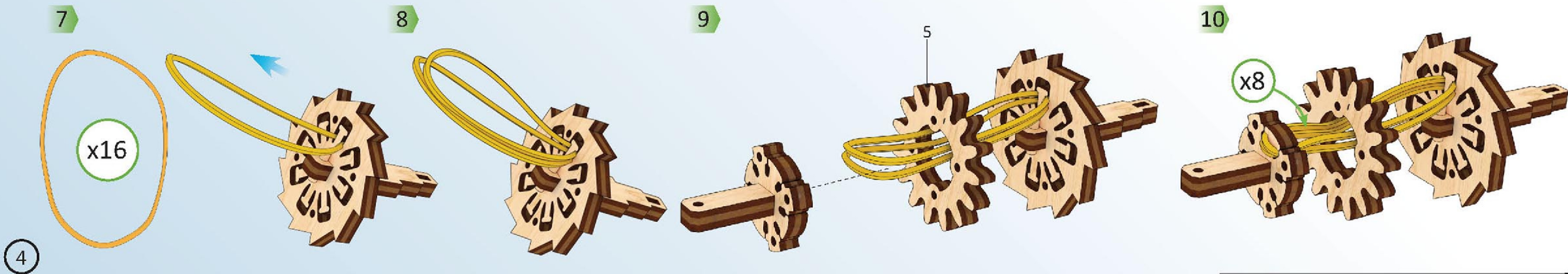
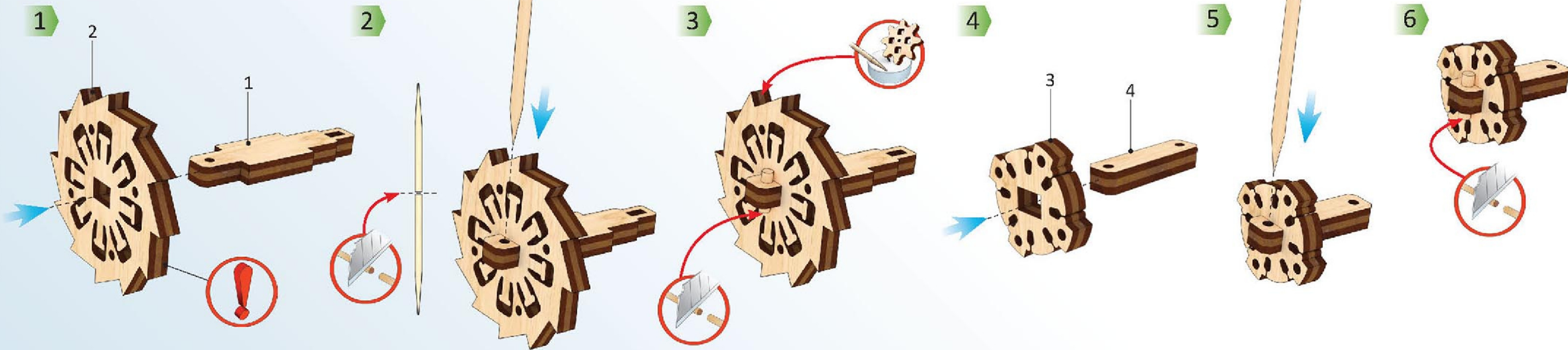
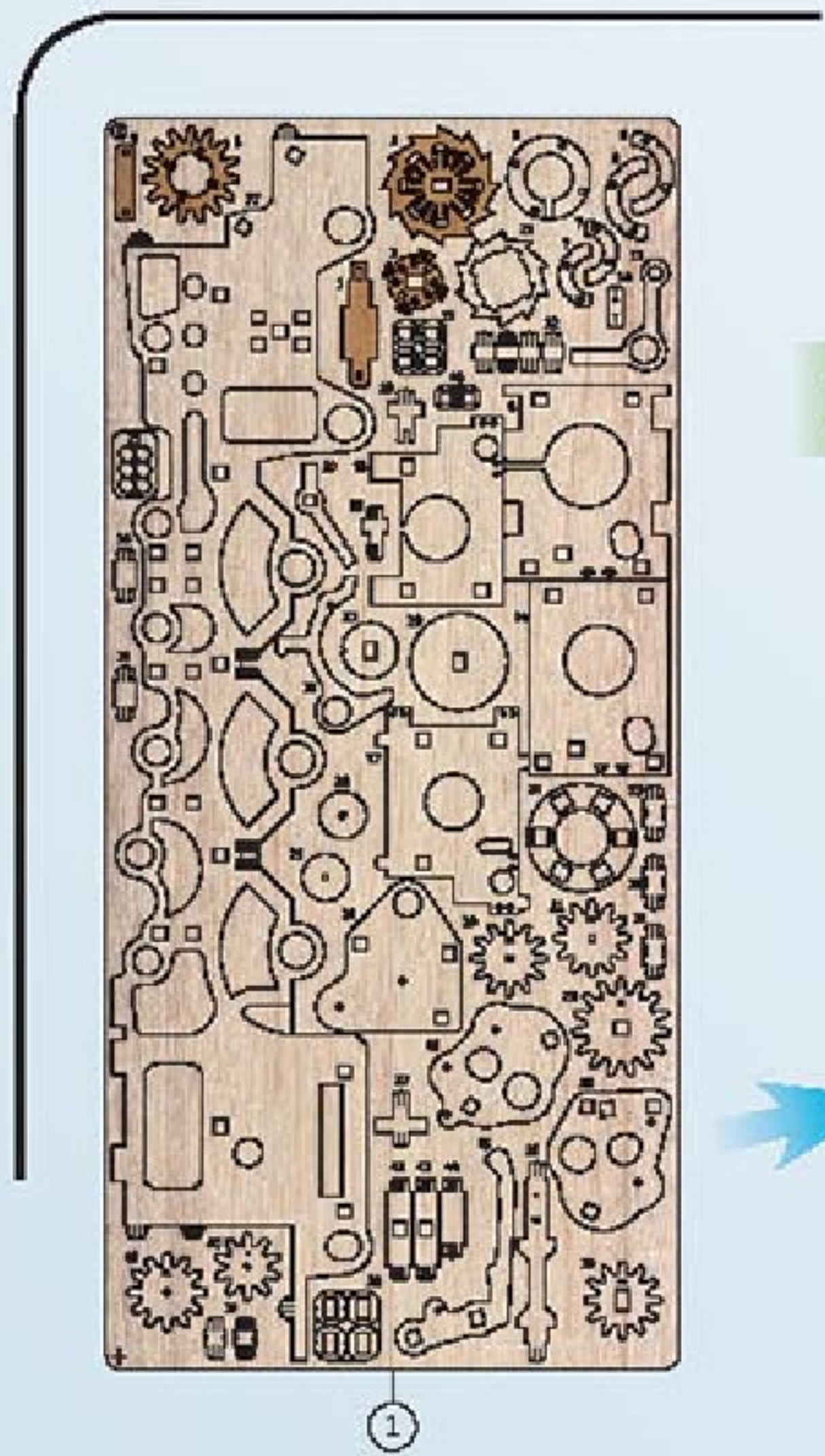

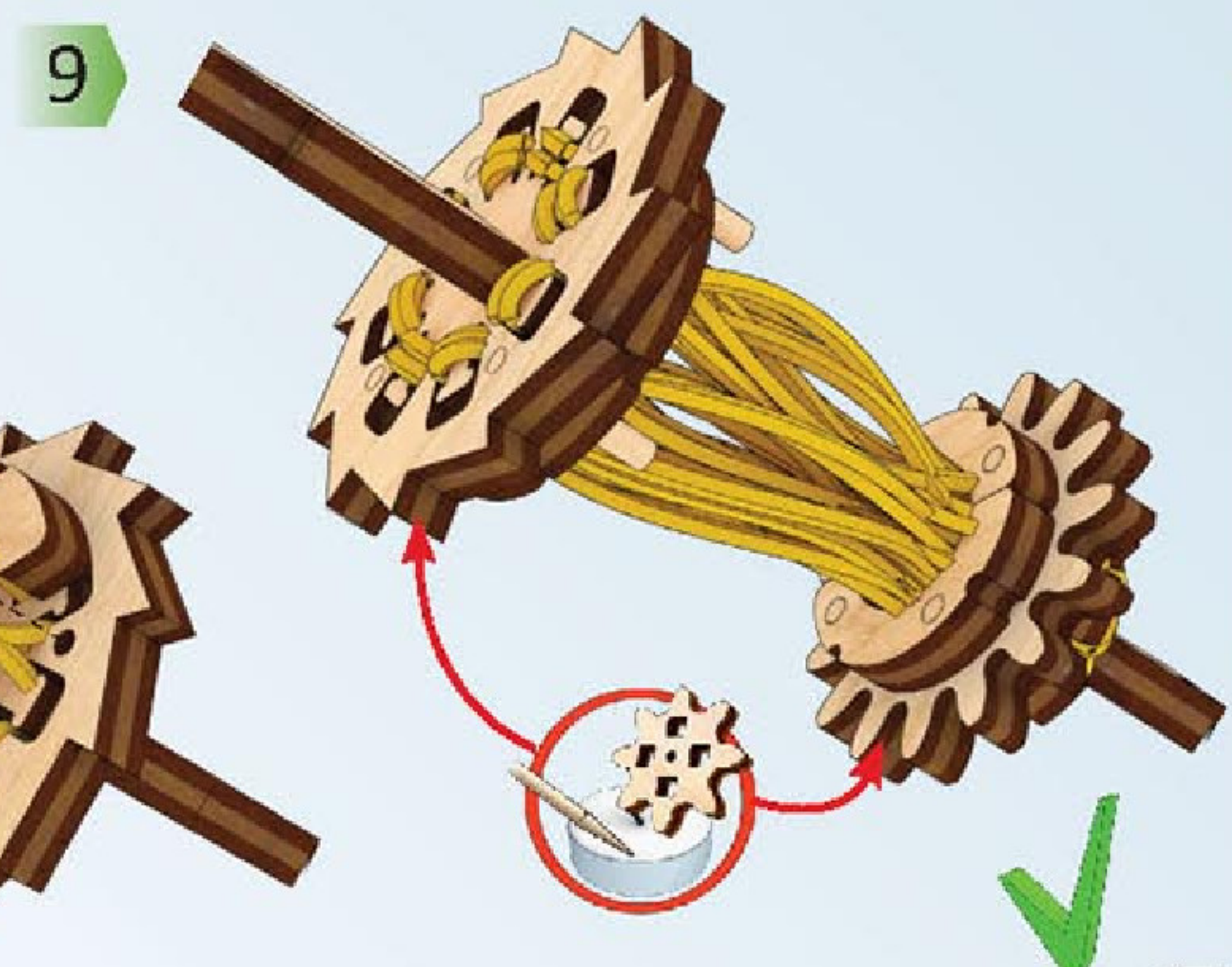
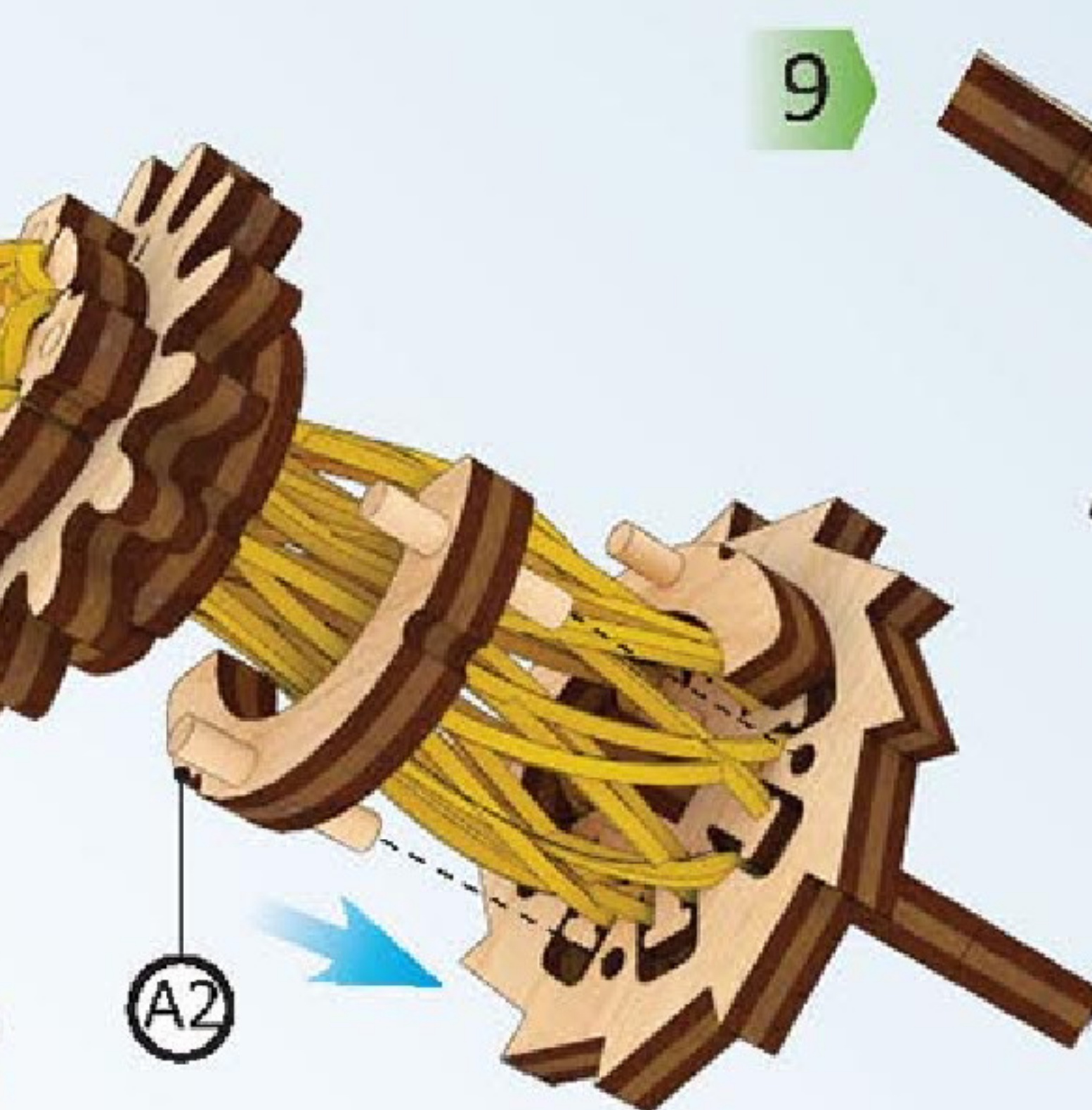
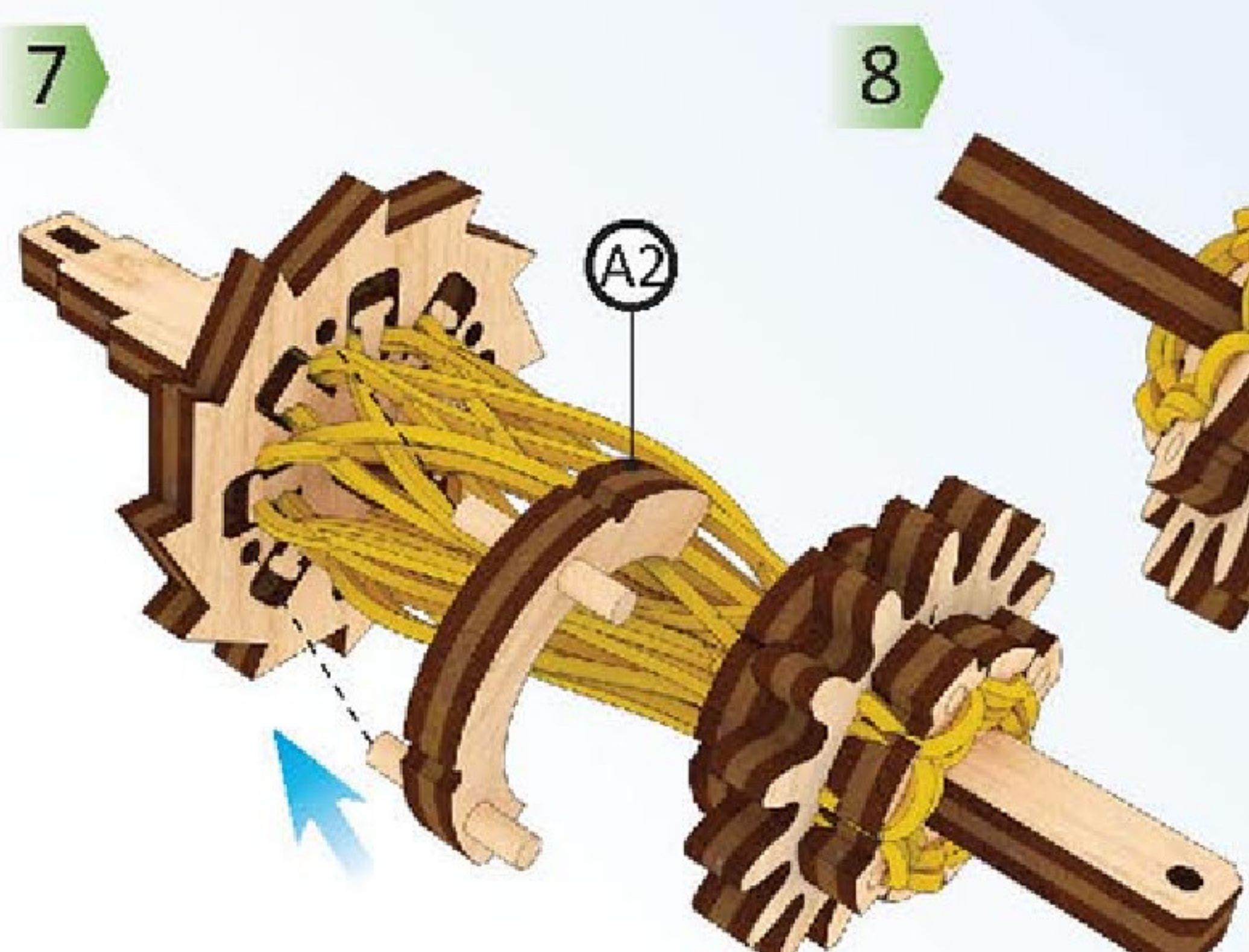
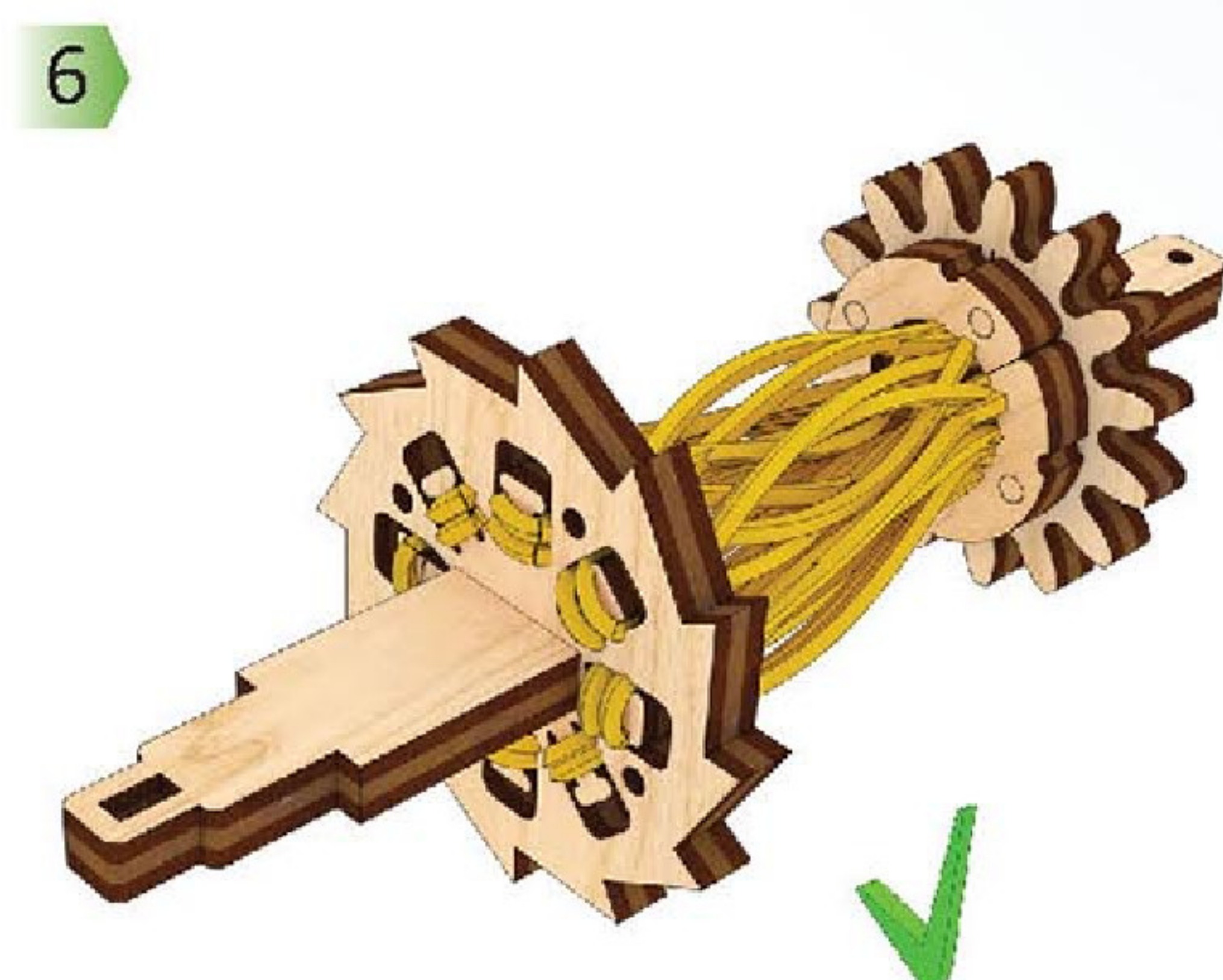
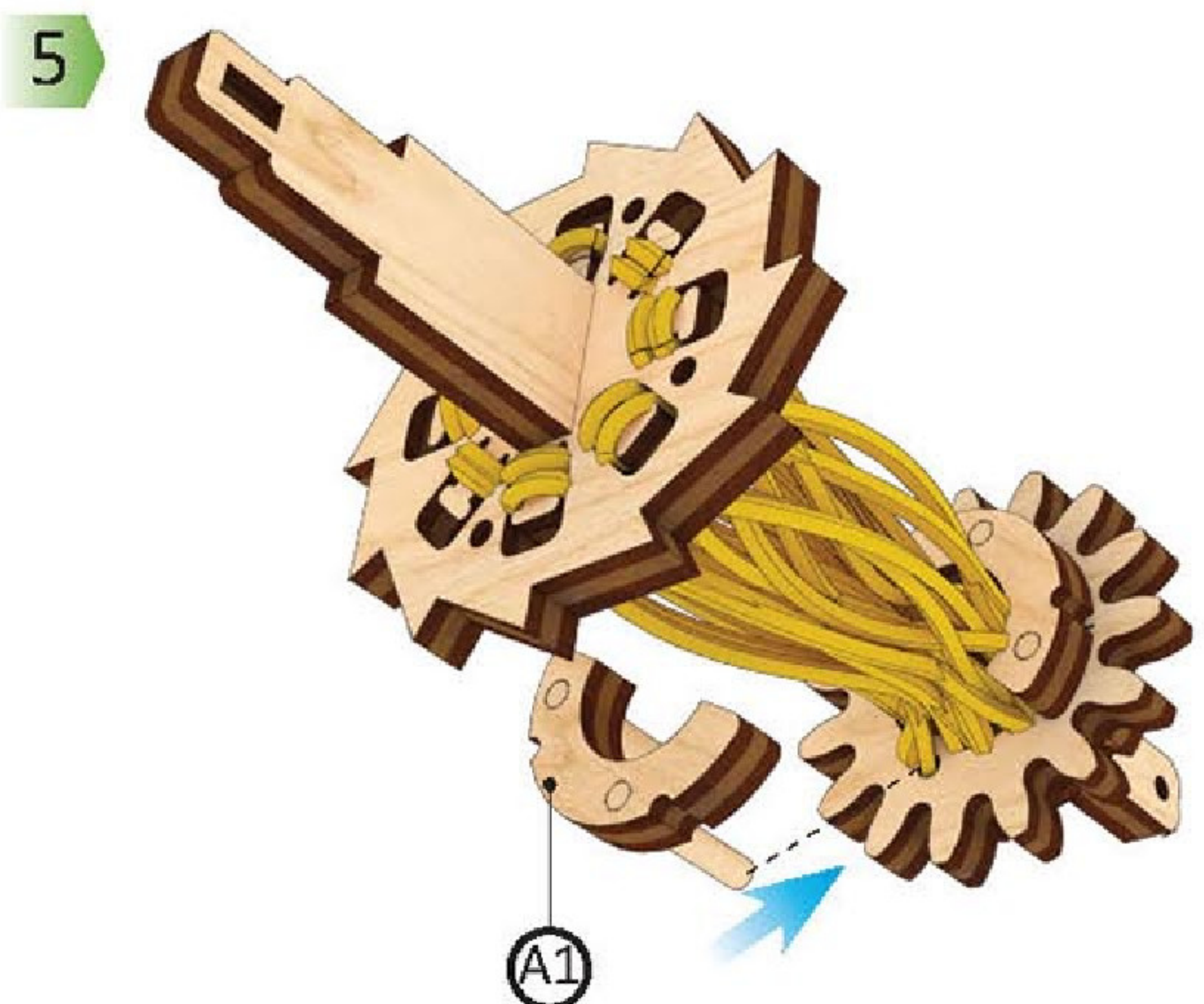
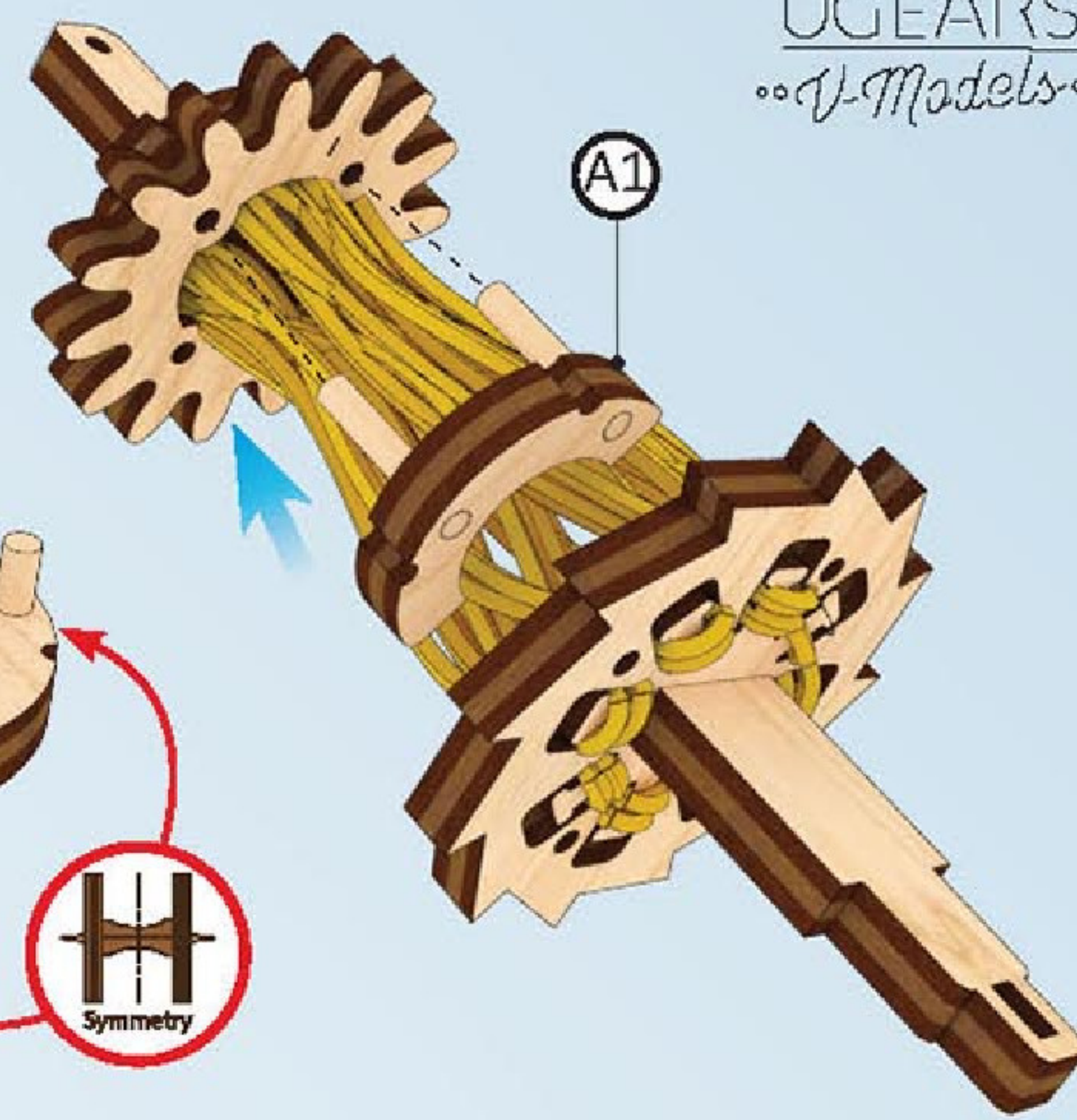
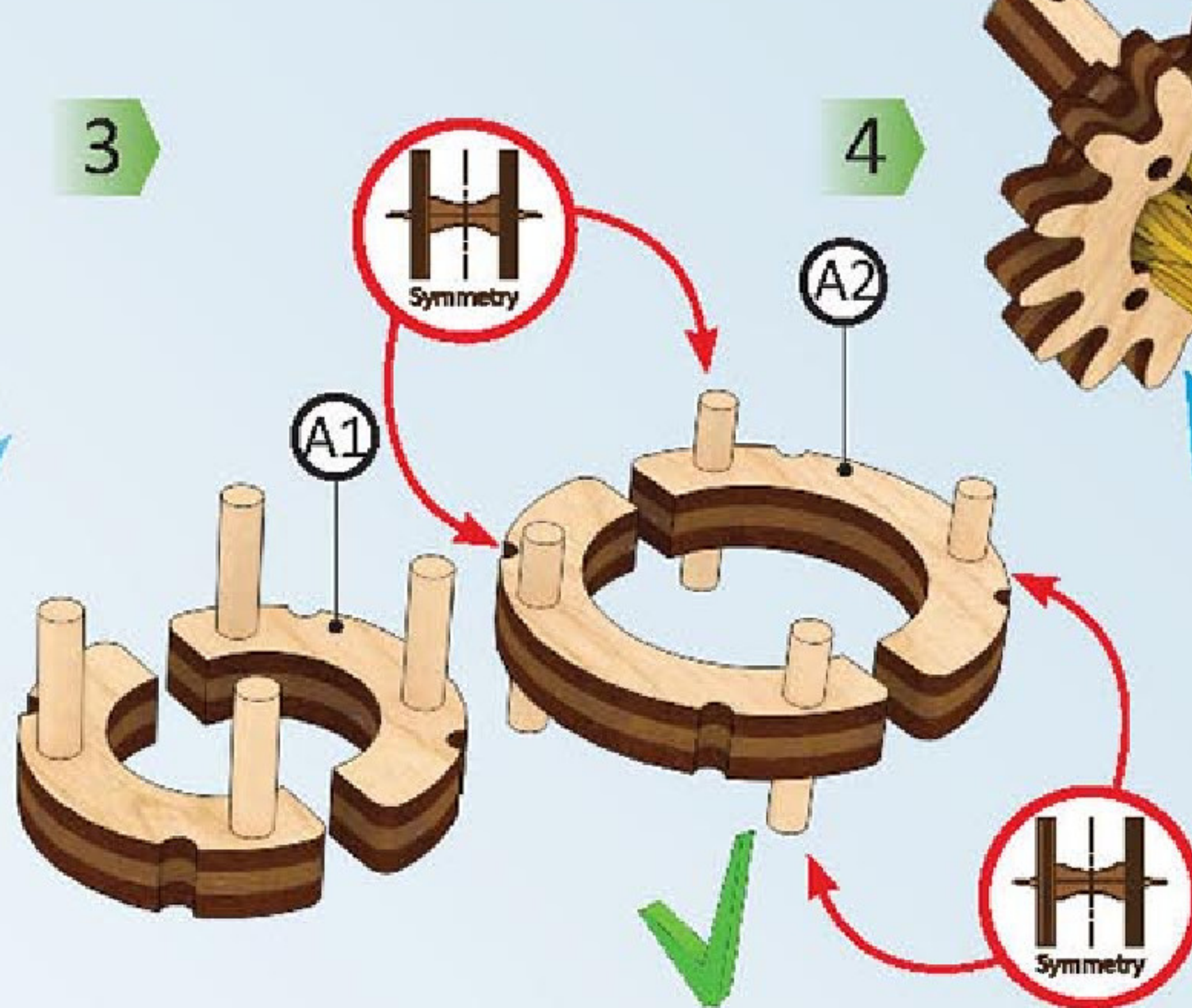
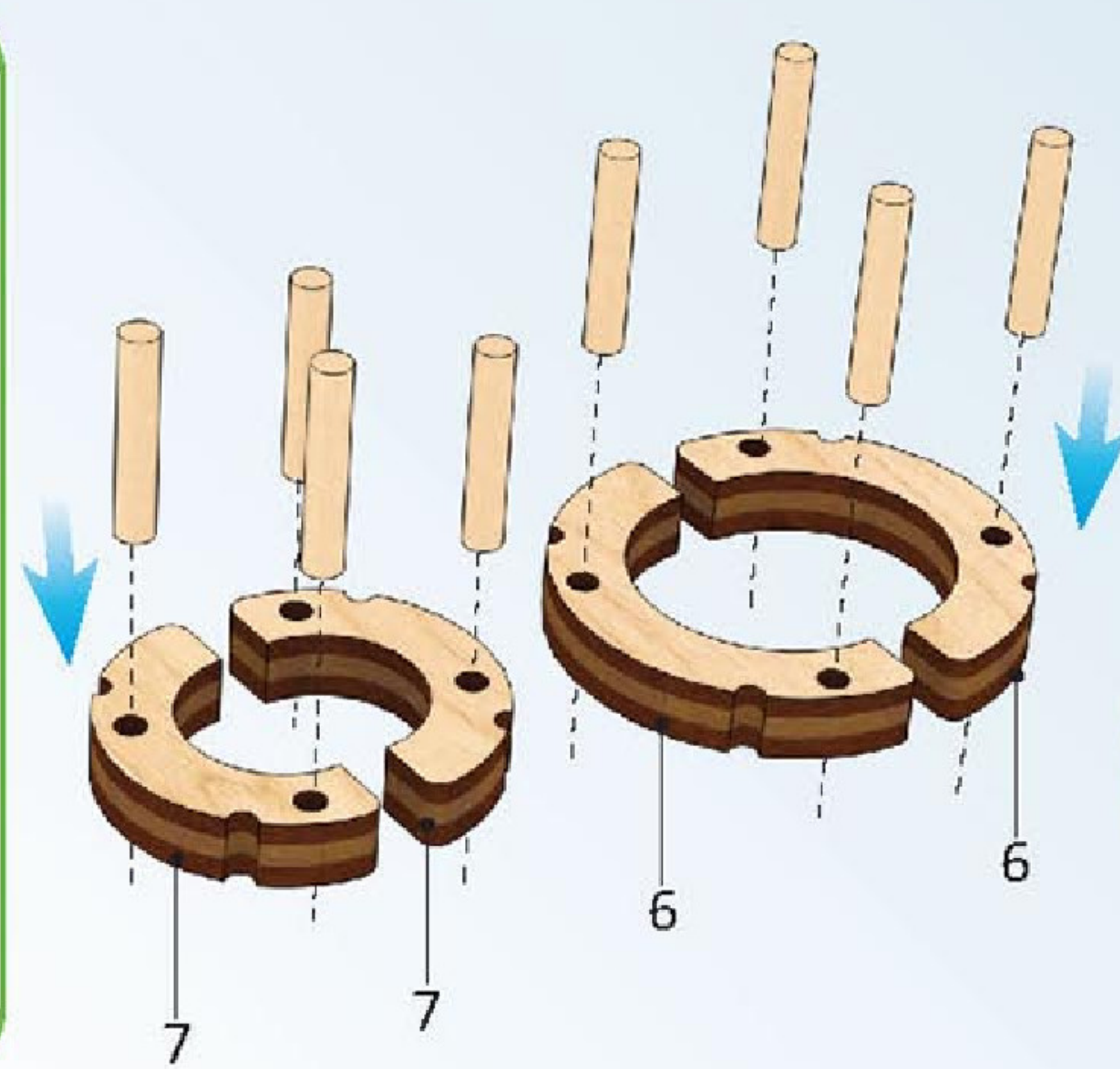
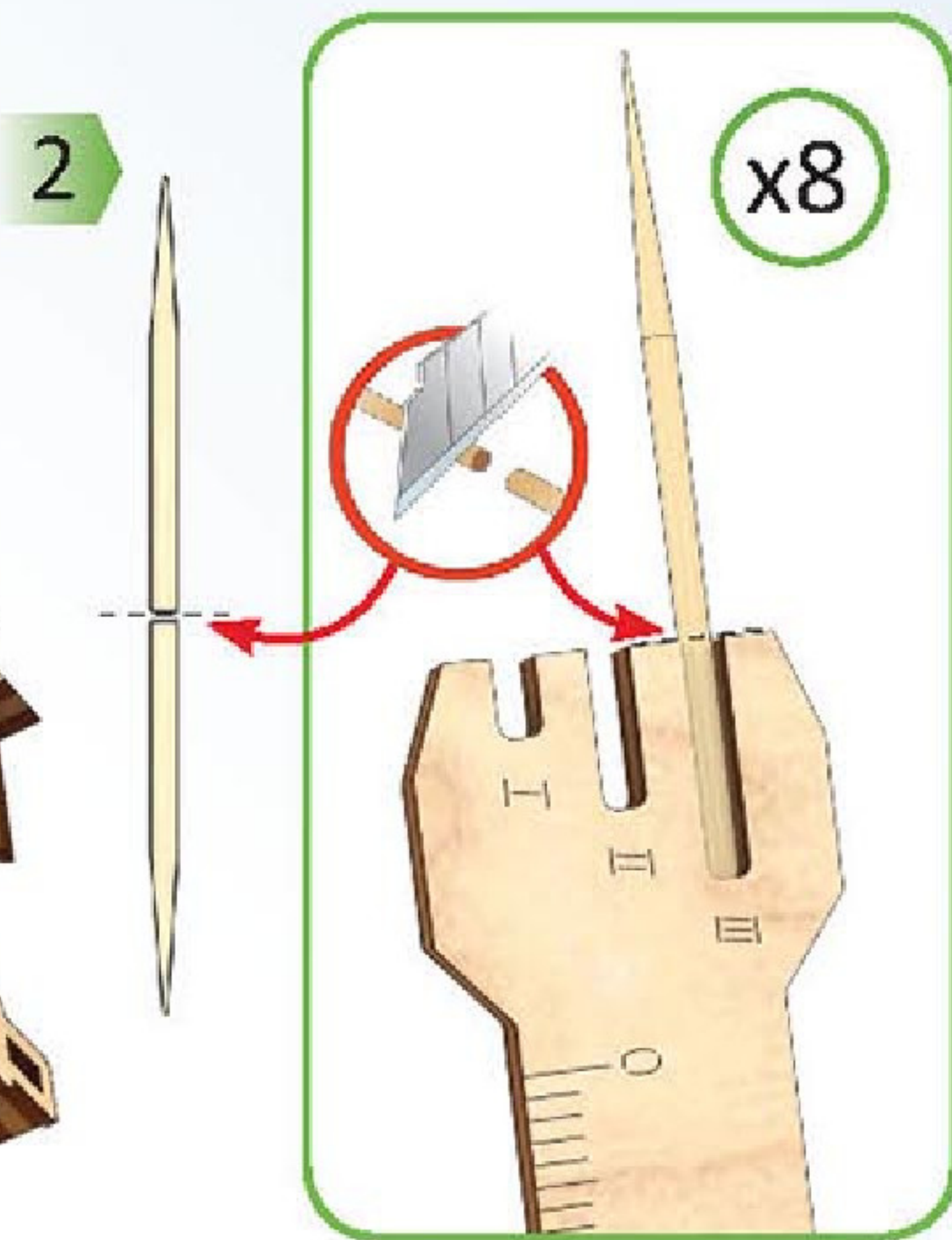
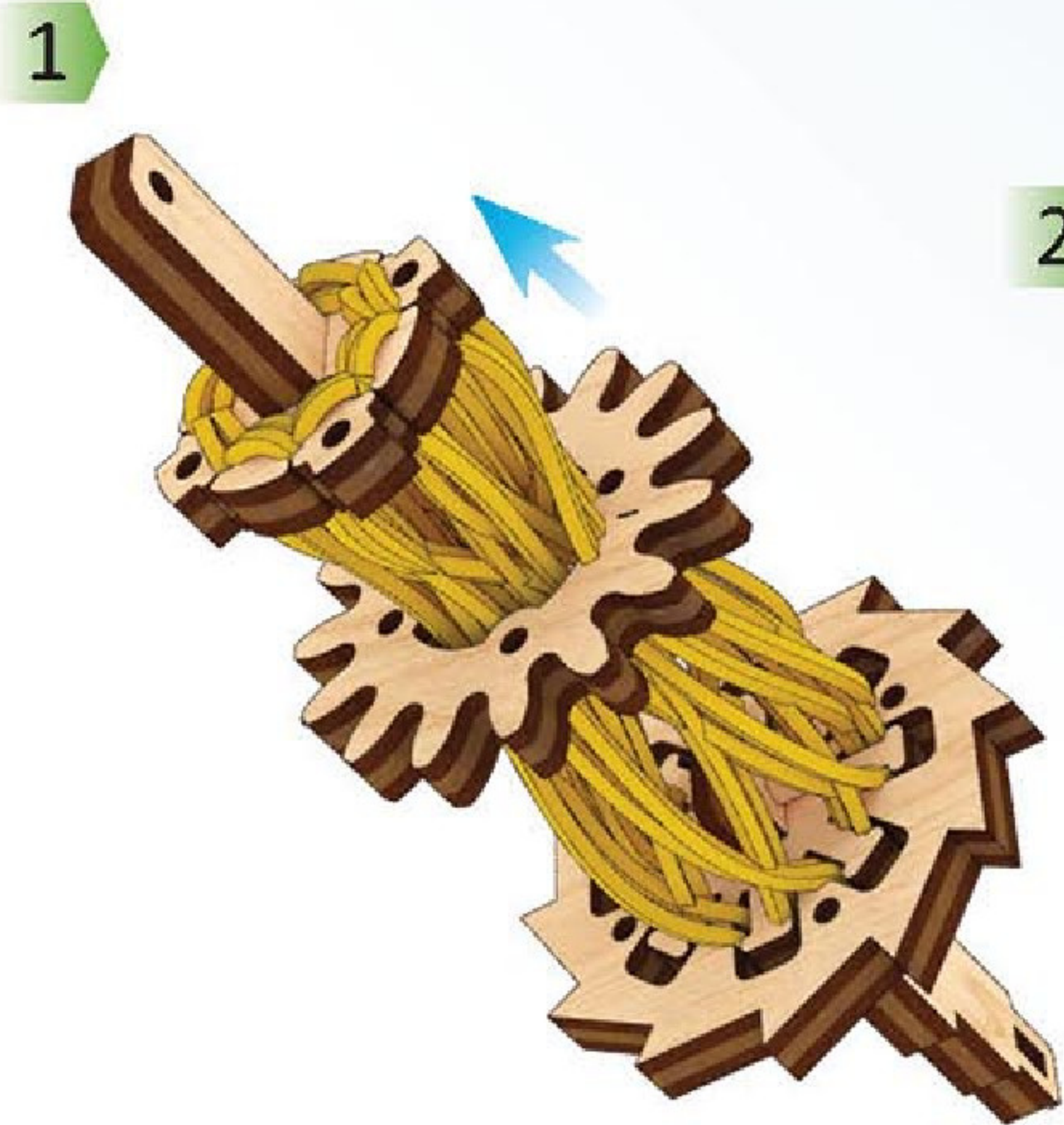
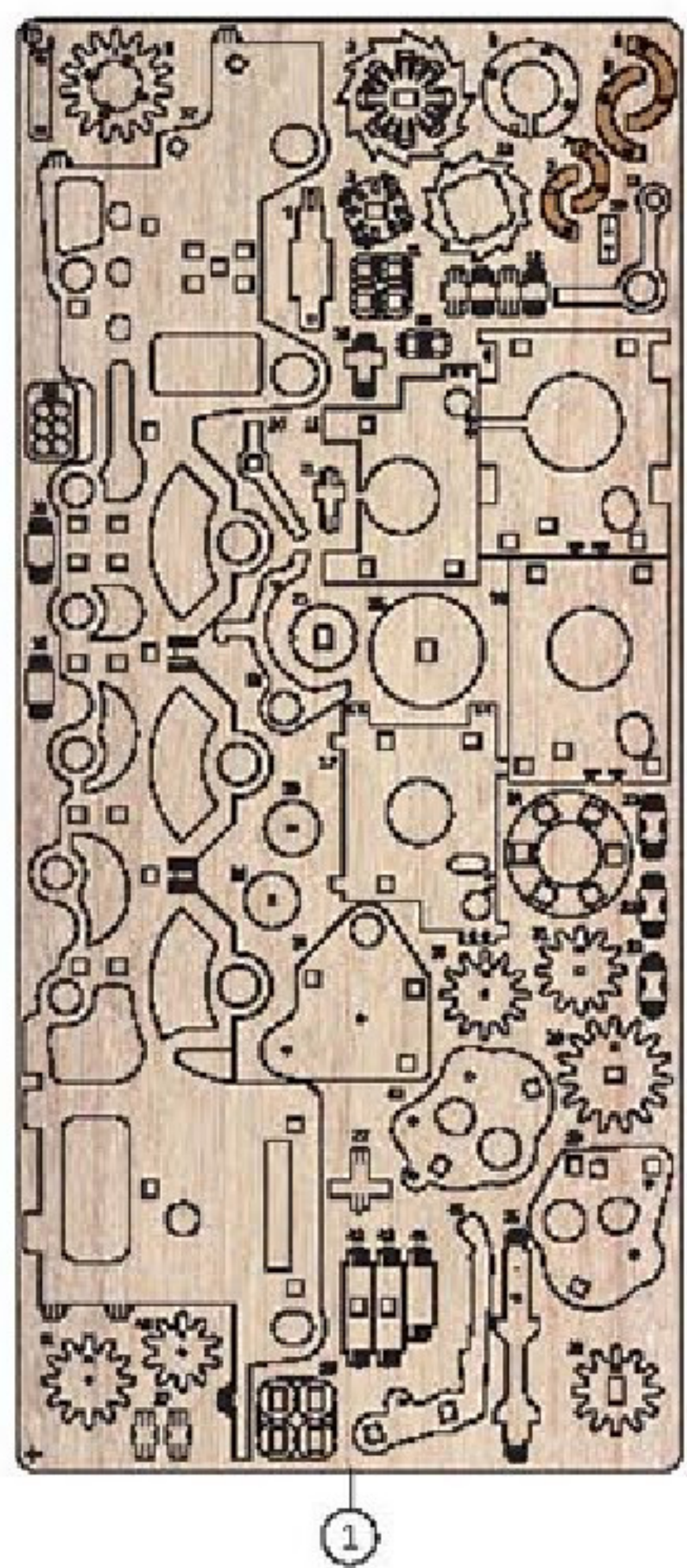

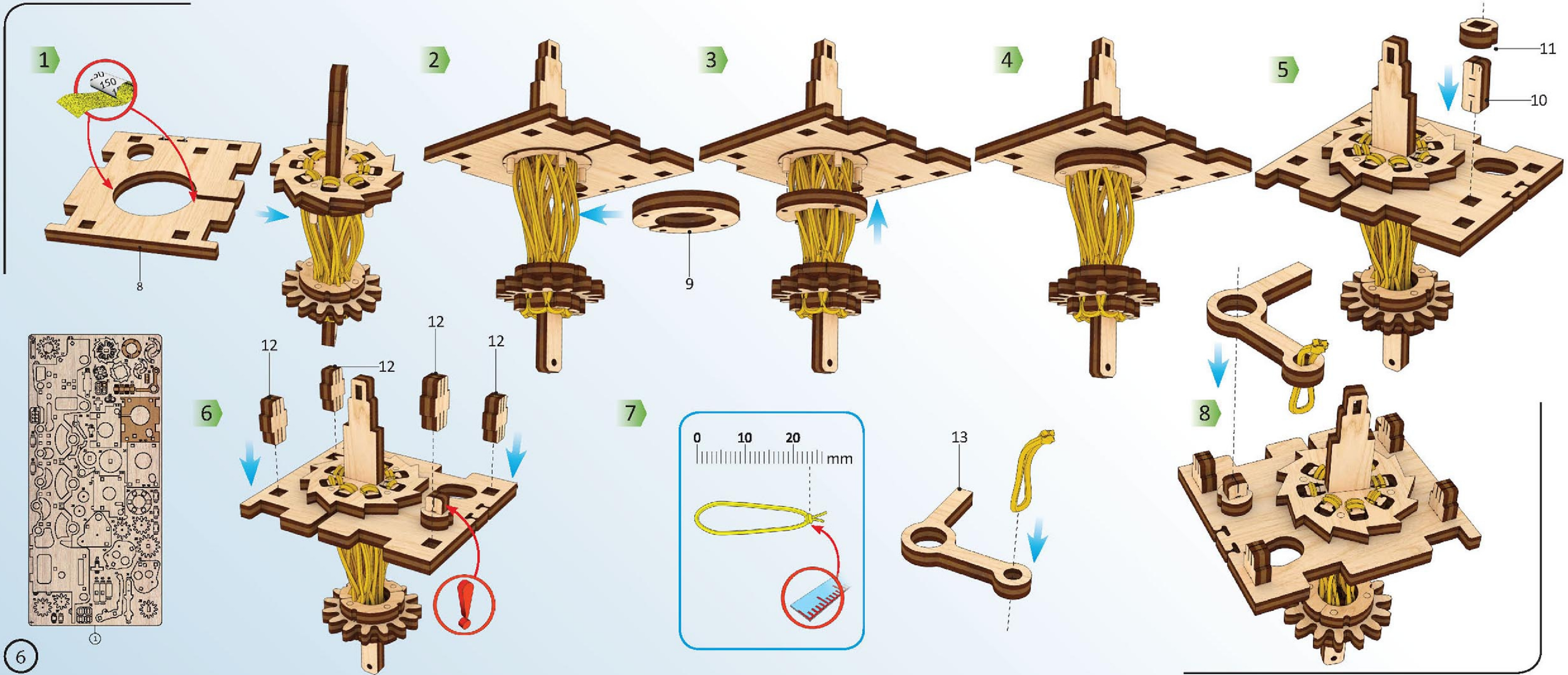

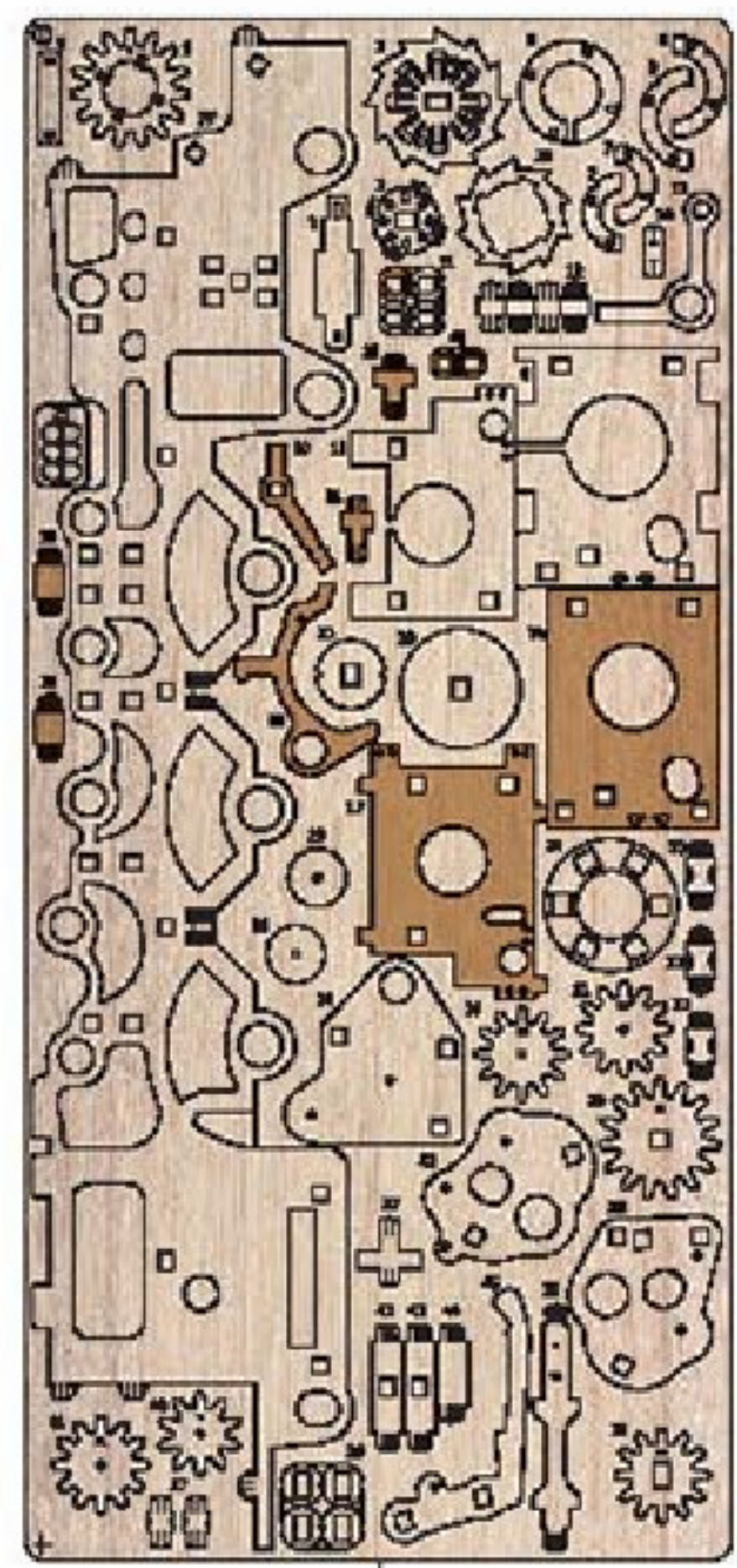

1

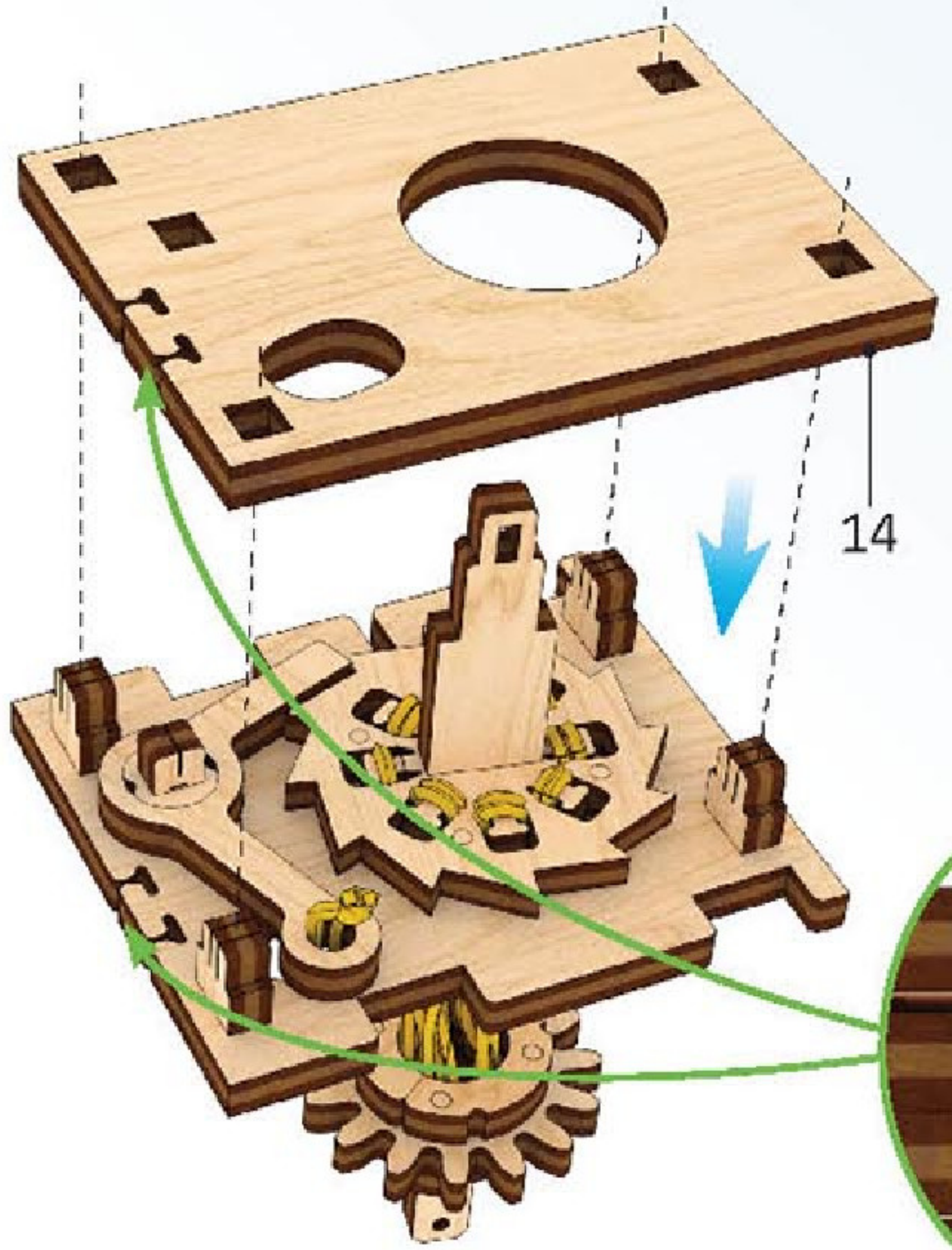

2



3

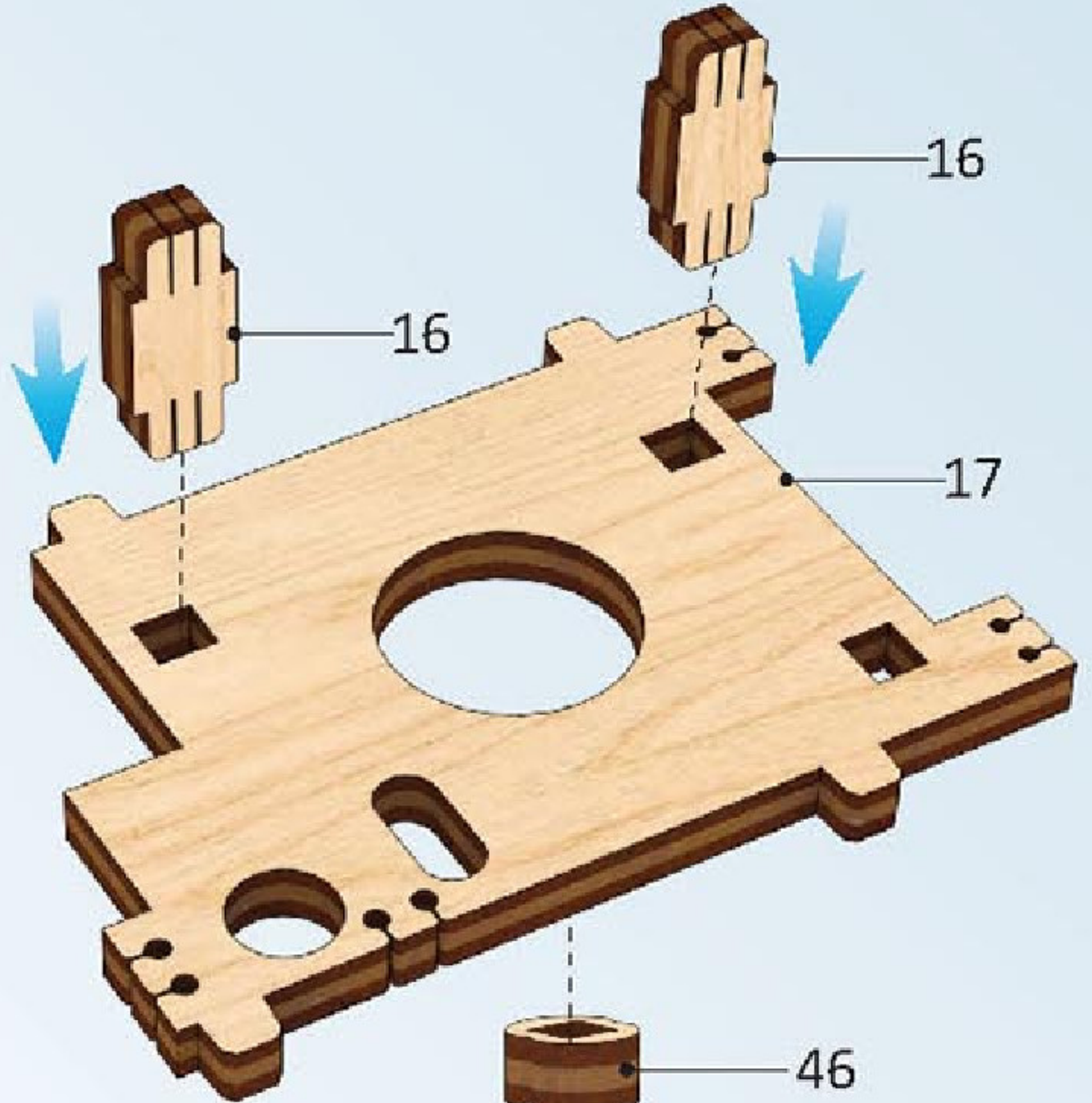

4

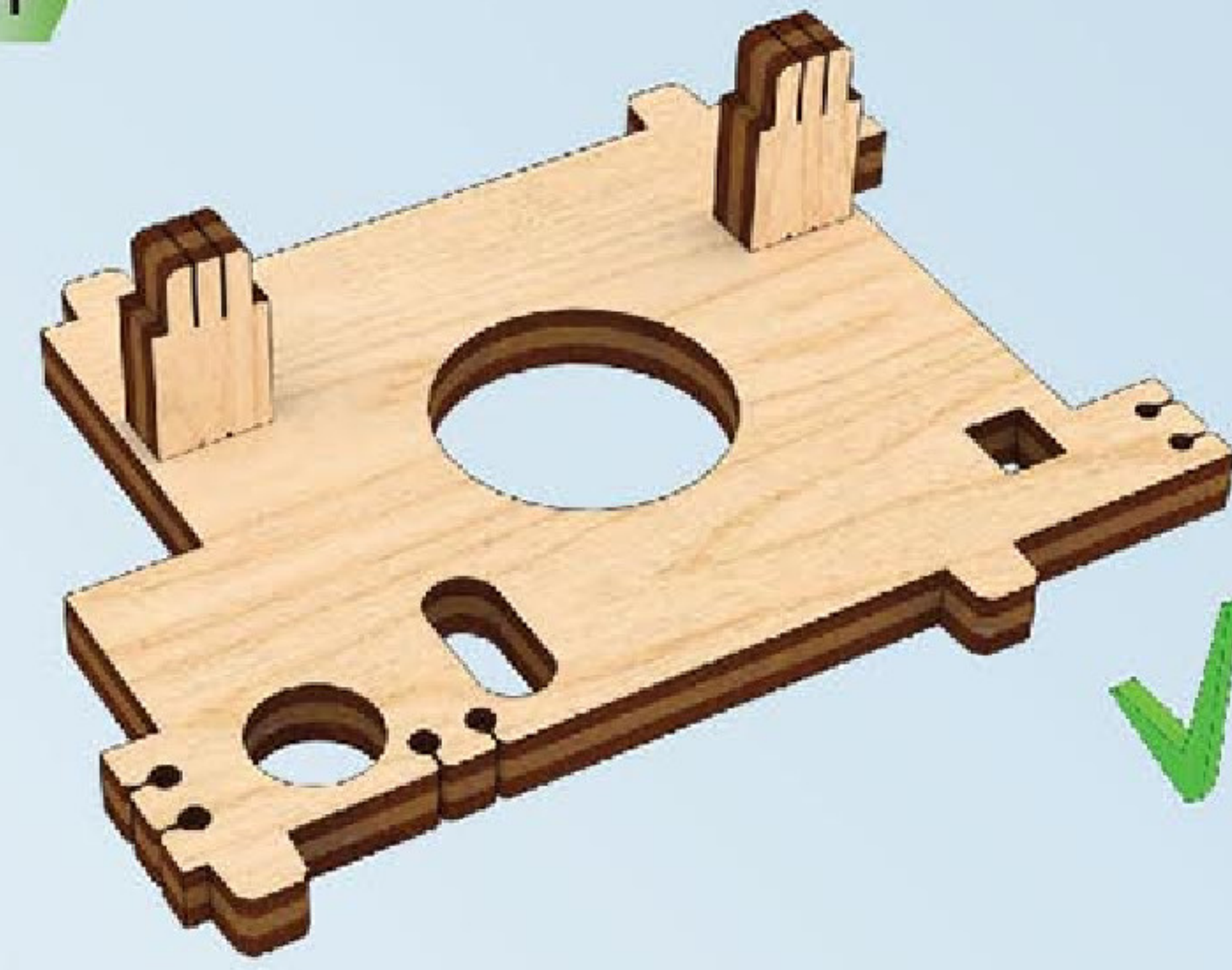

5

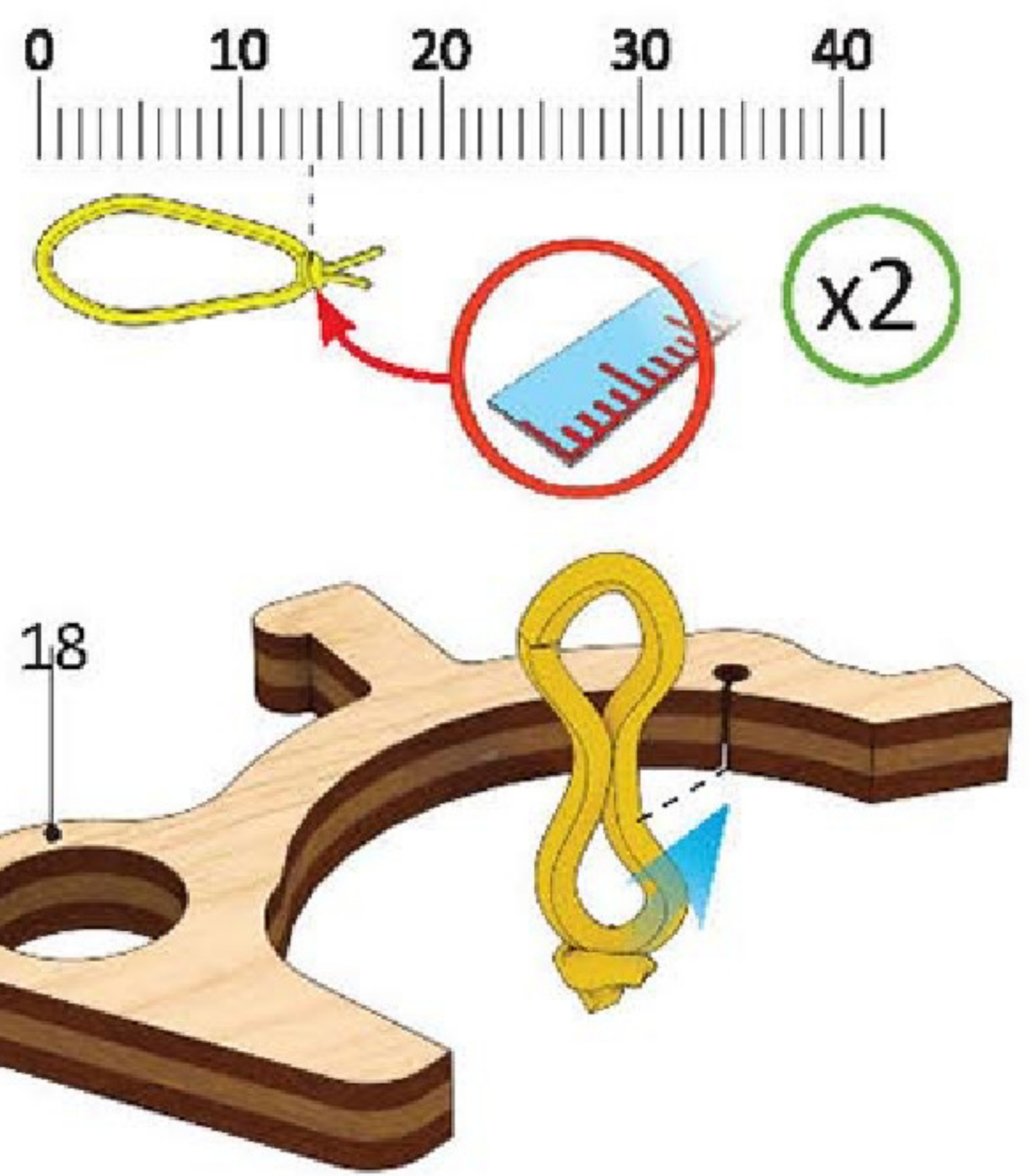

6

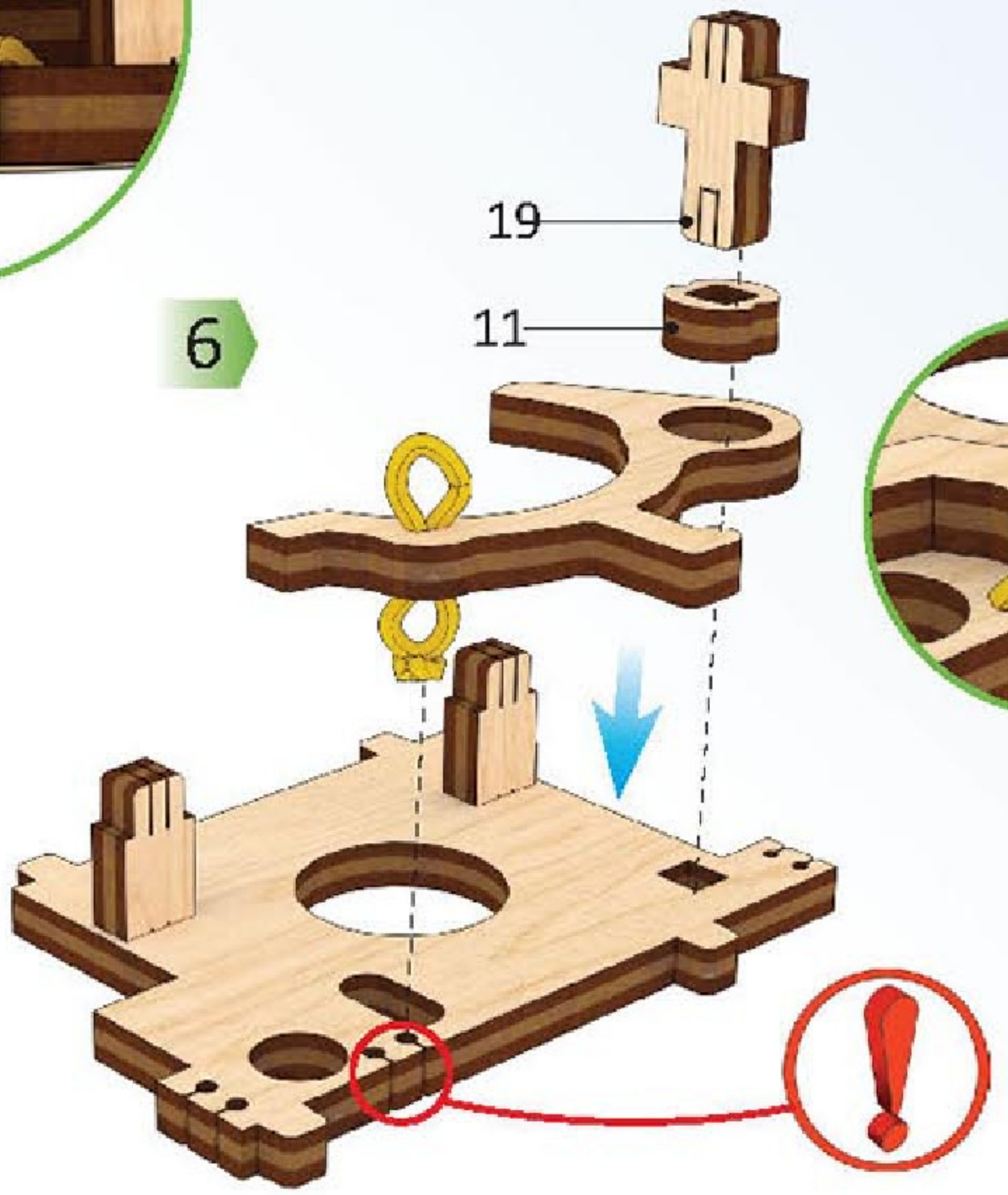

7

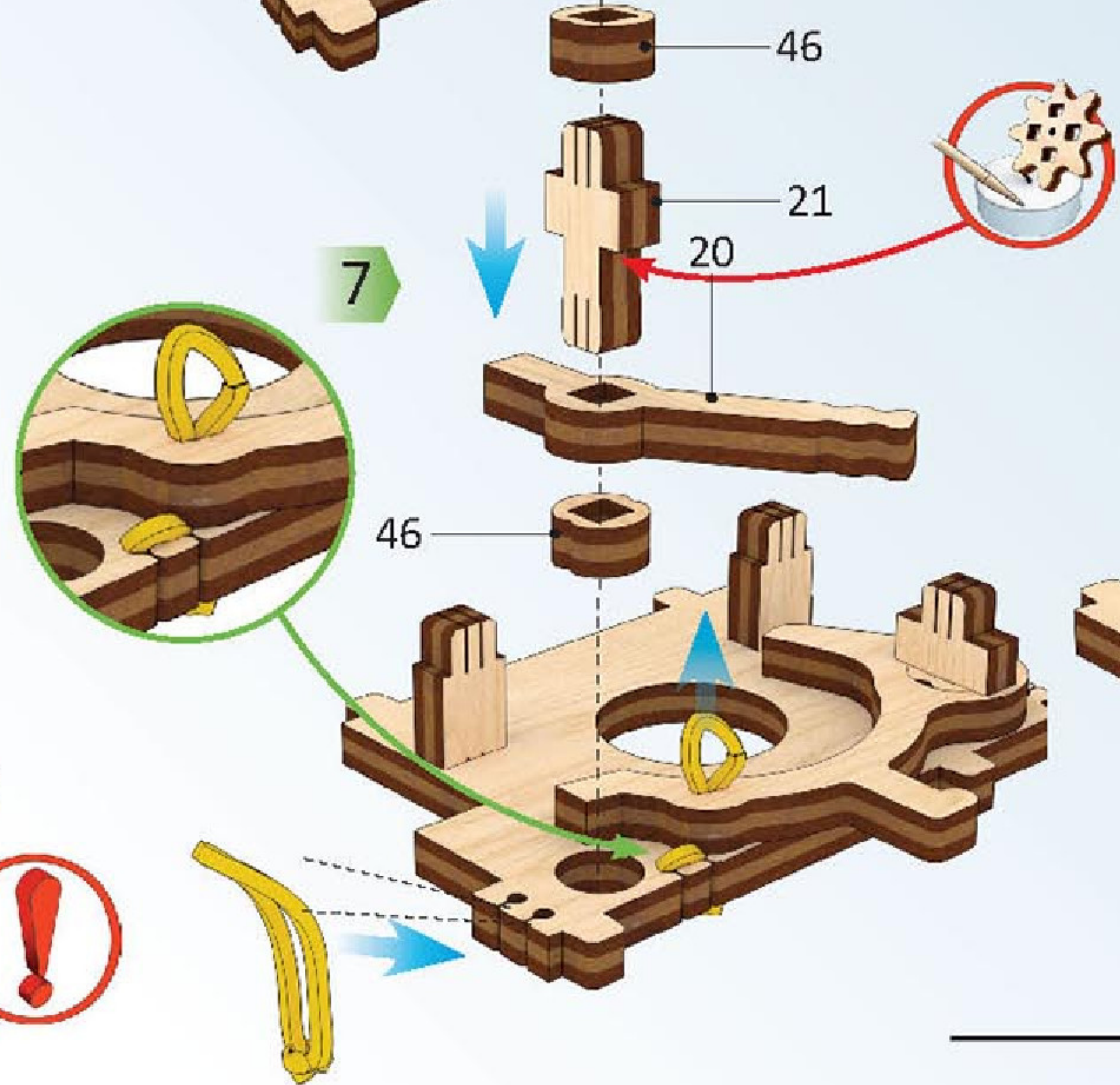

8

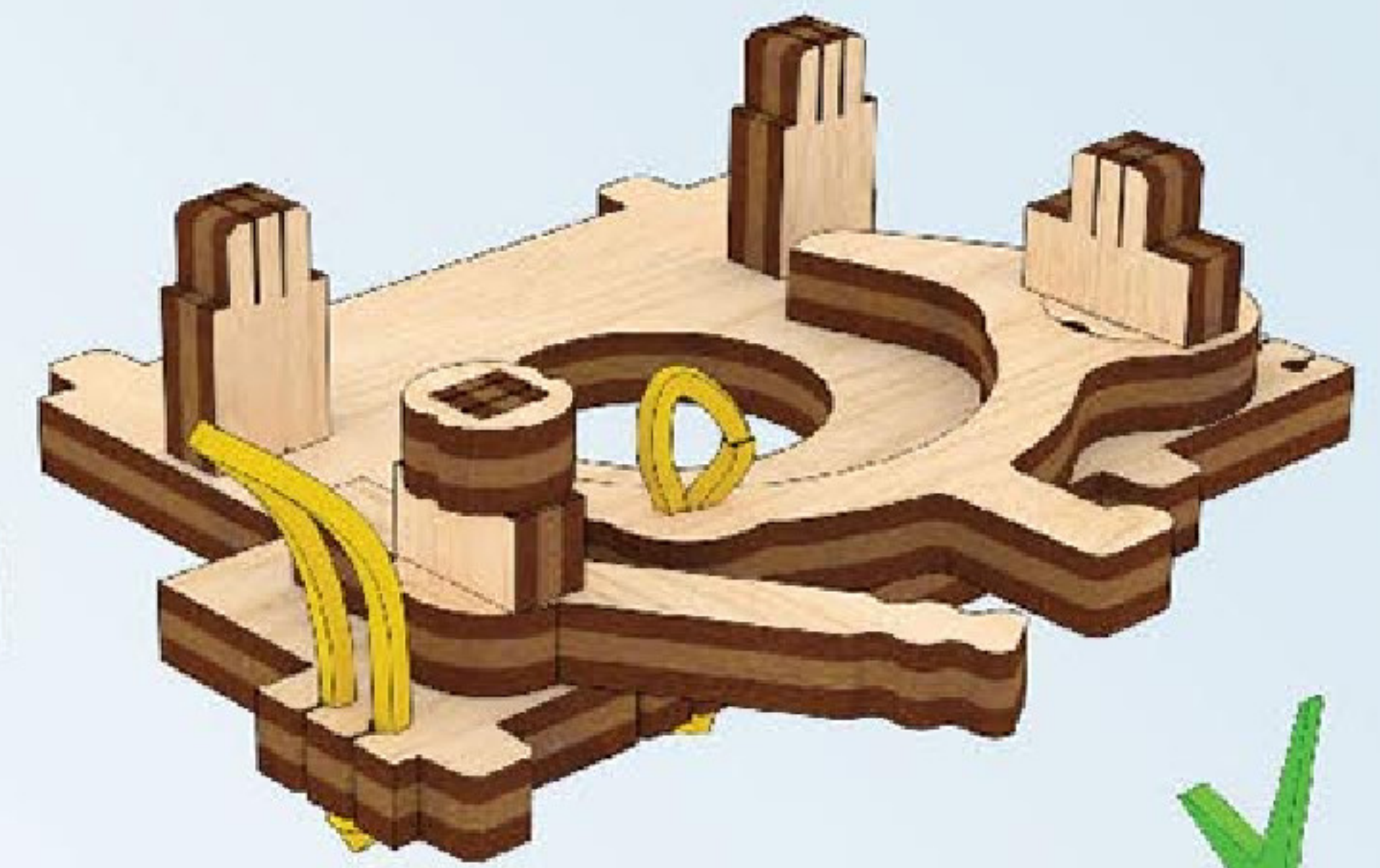

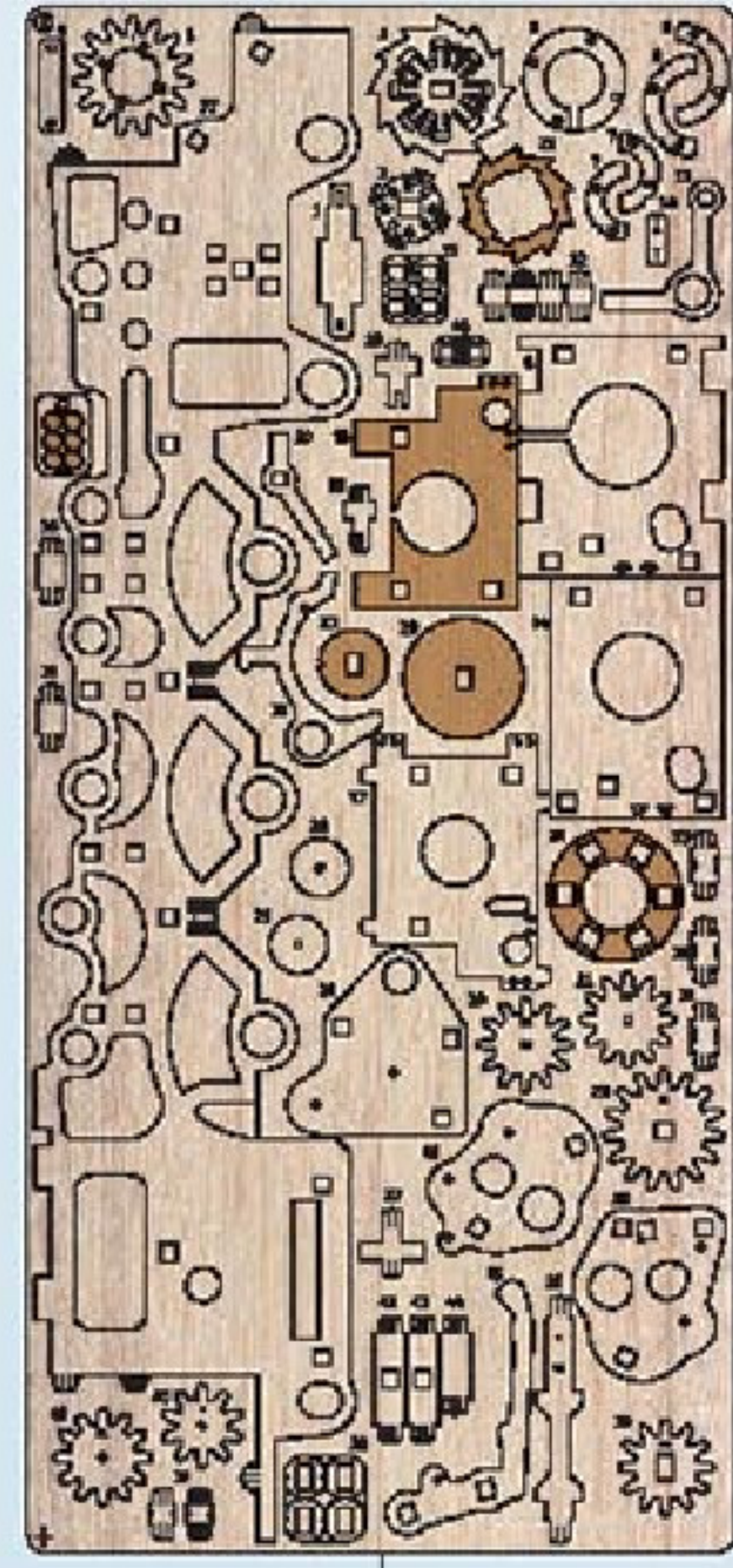

1

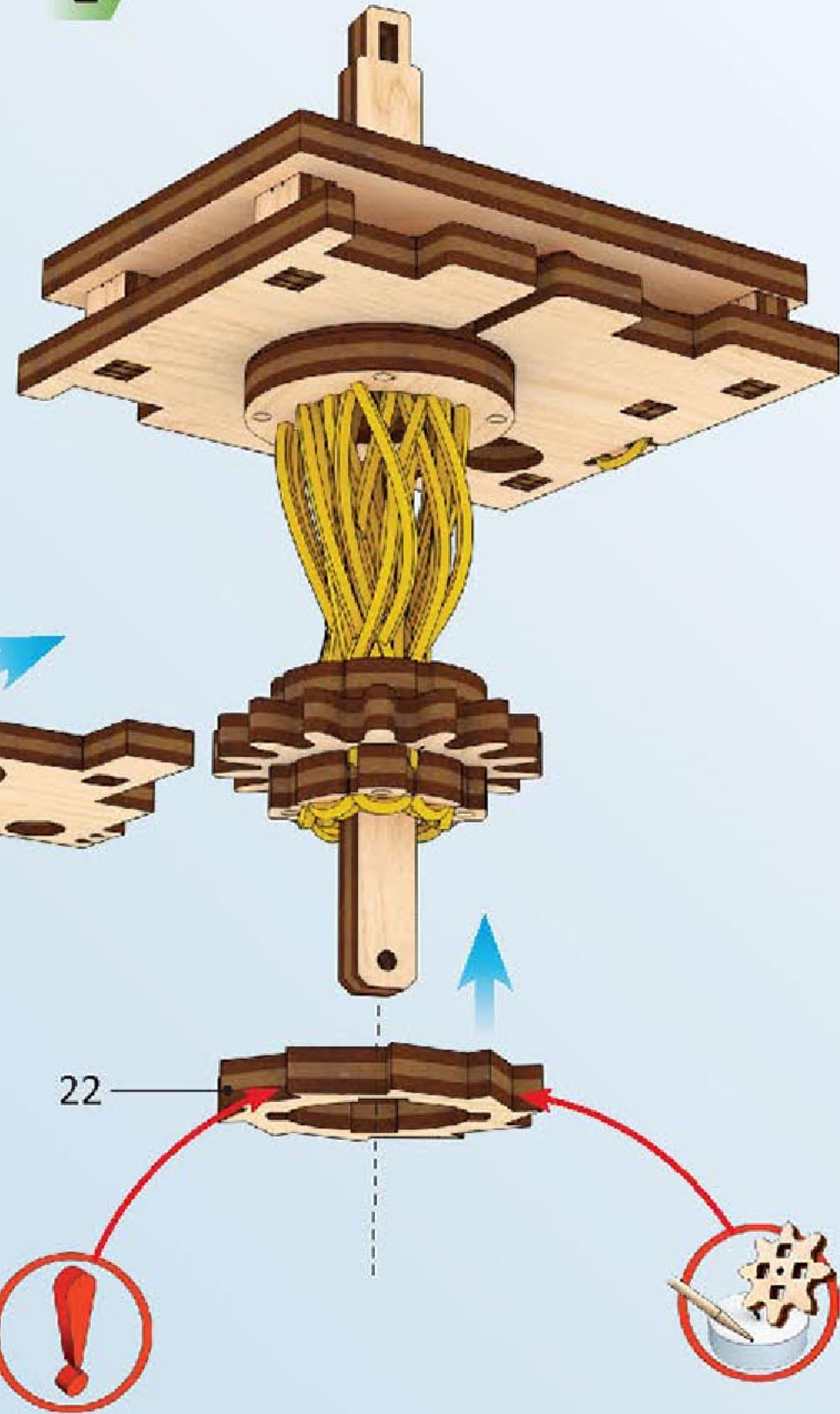

2

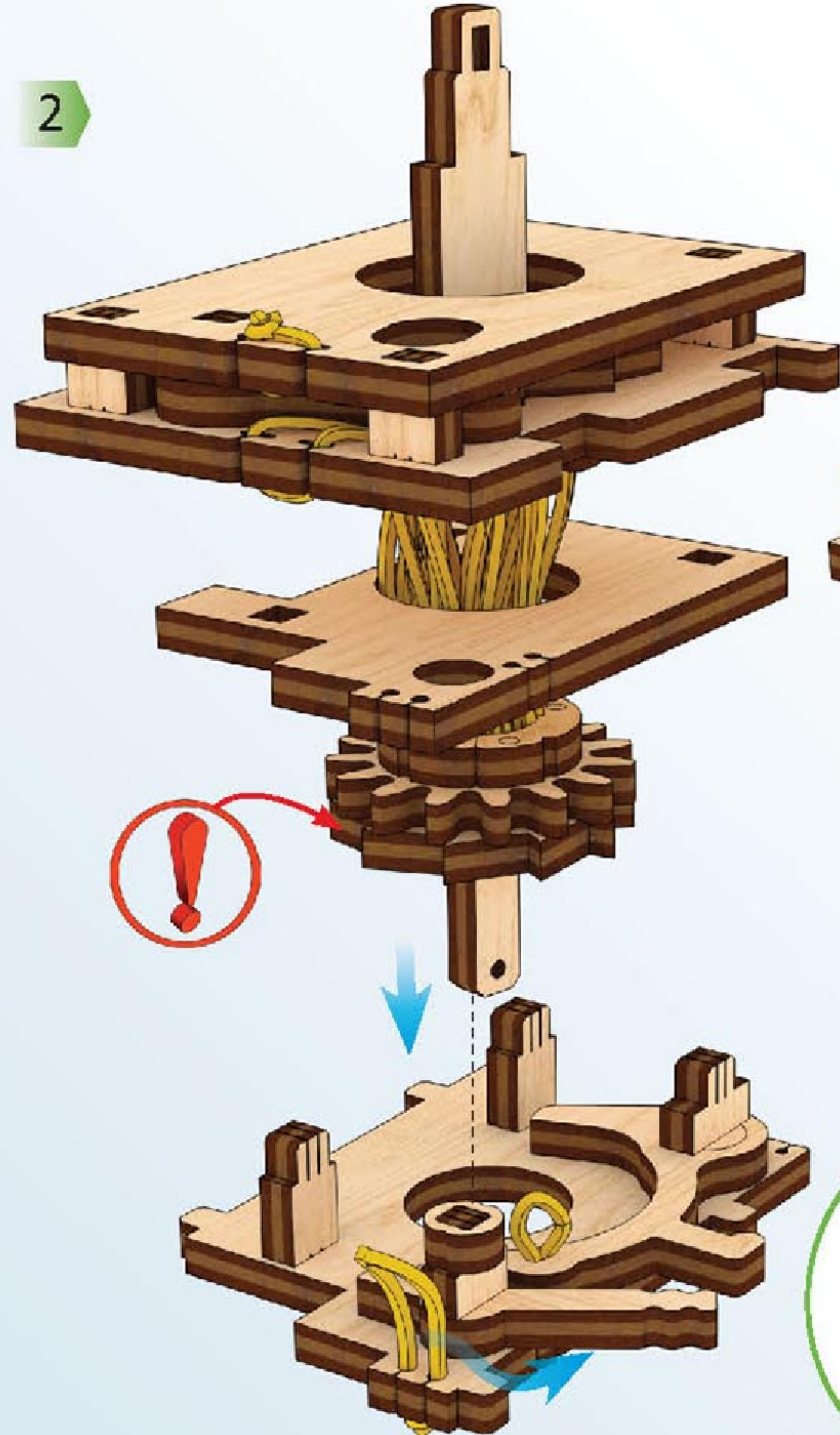

3

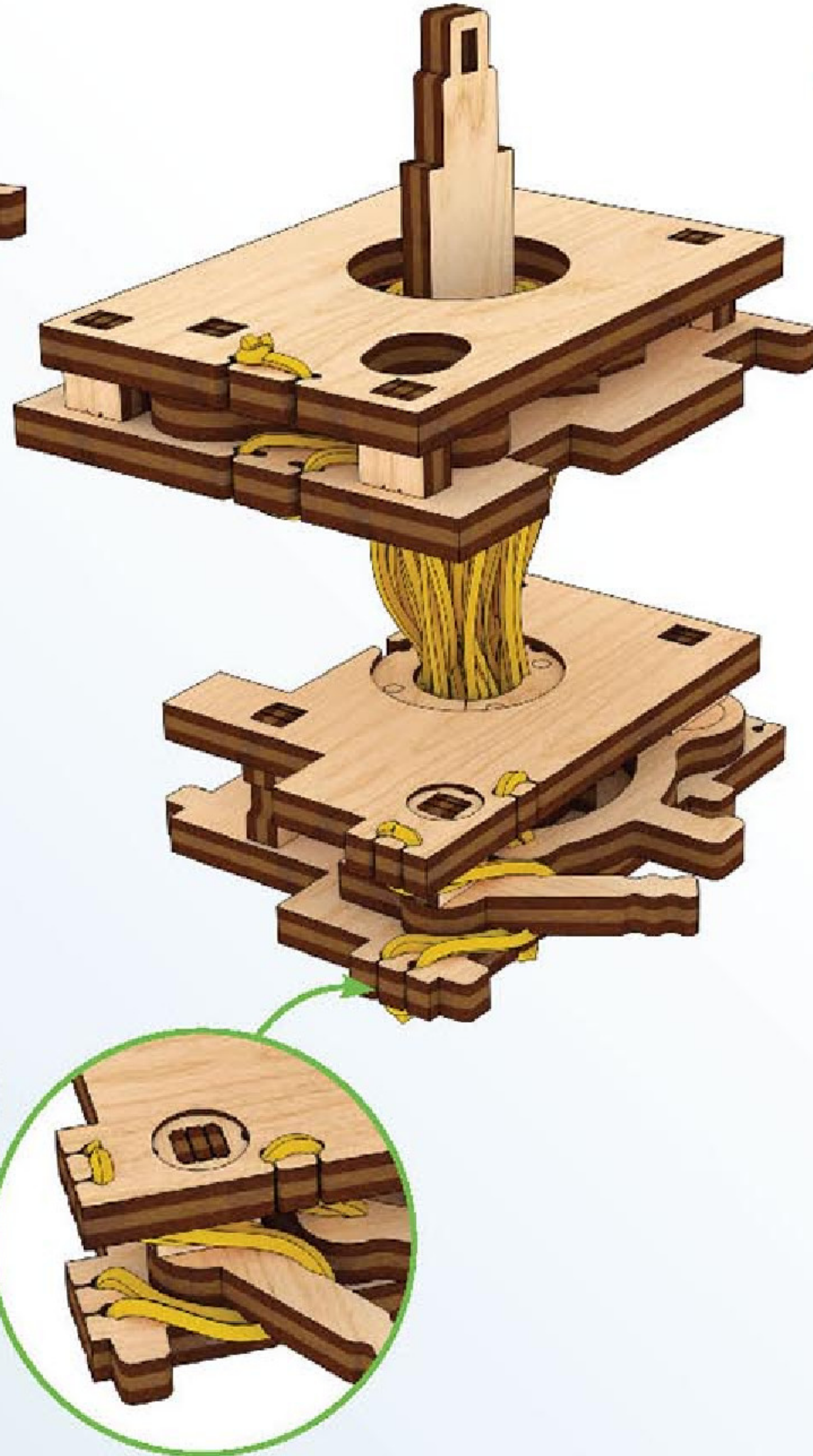

4

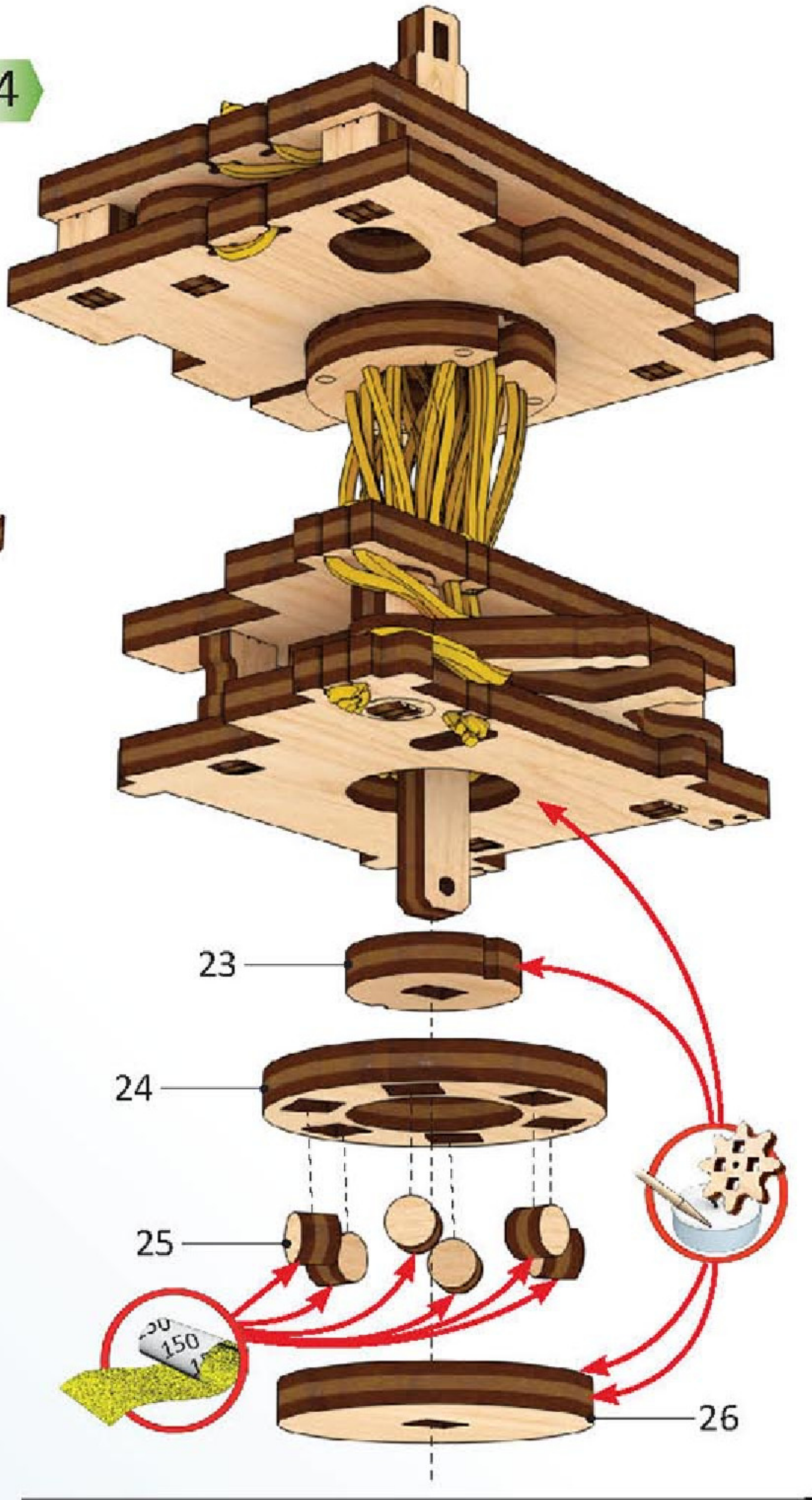



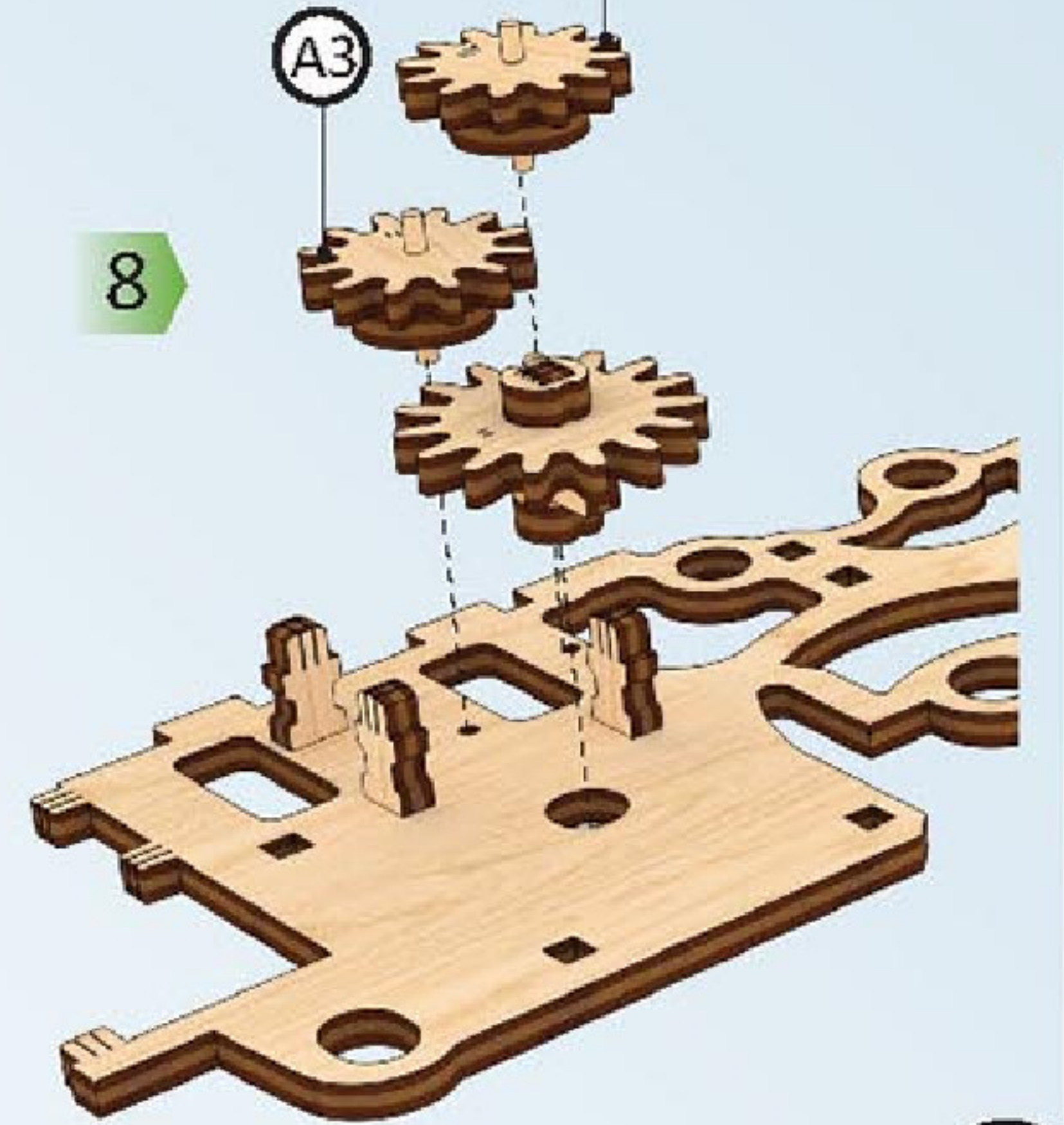
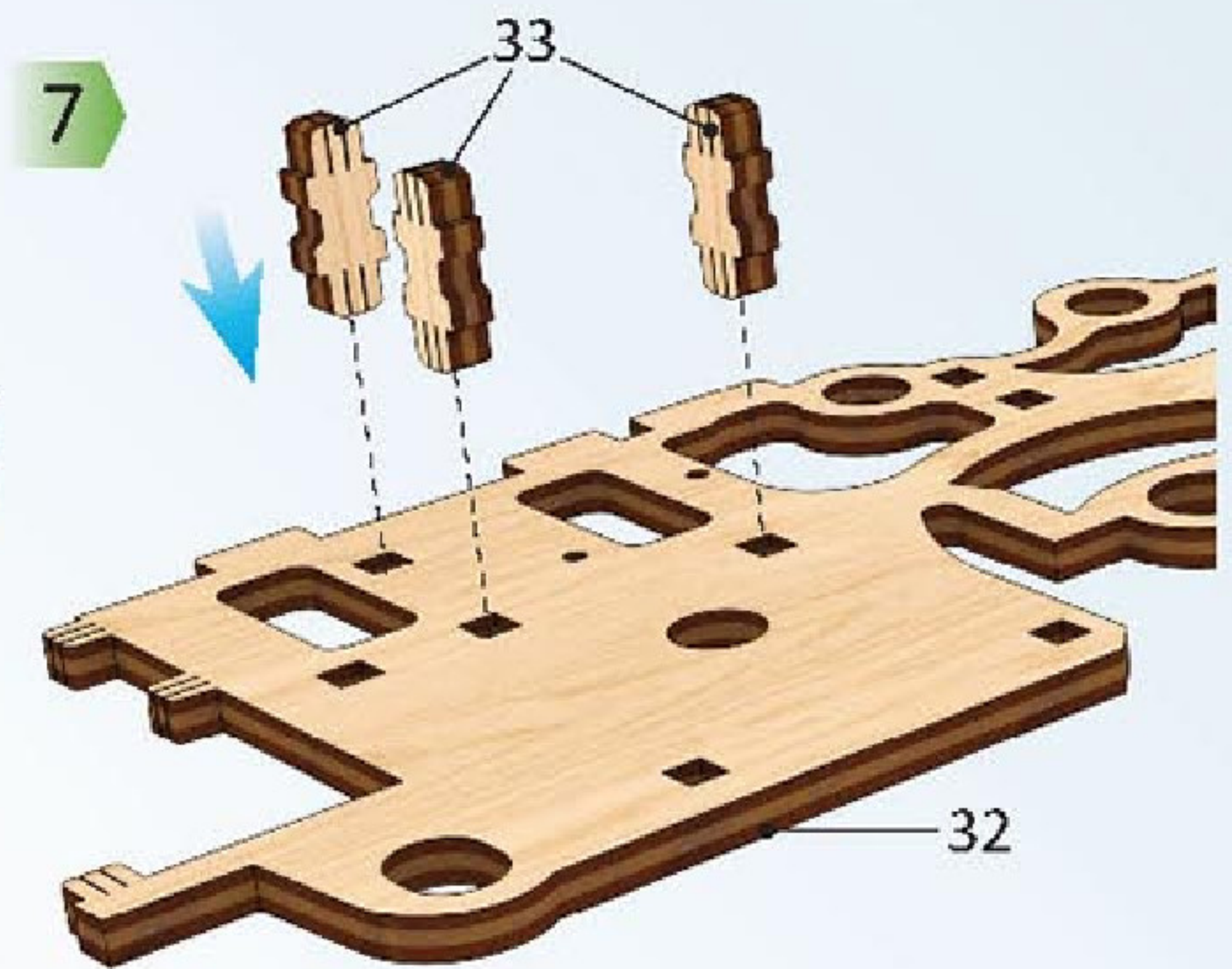
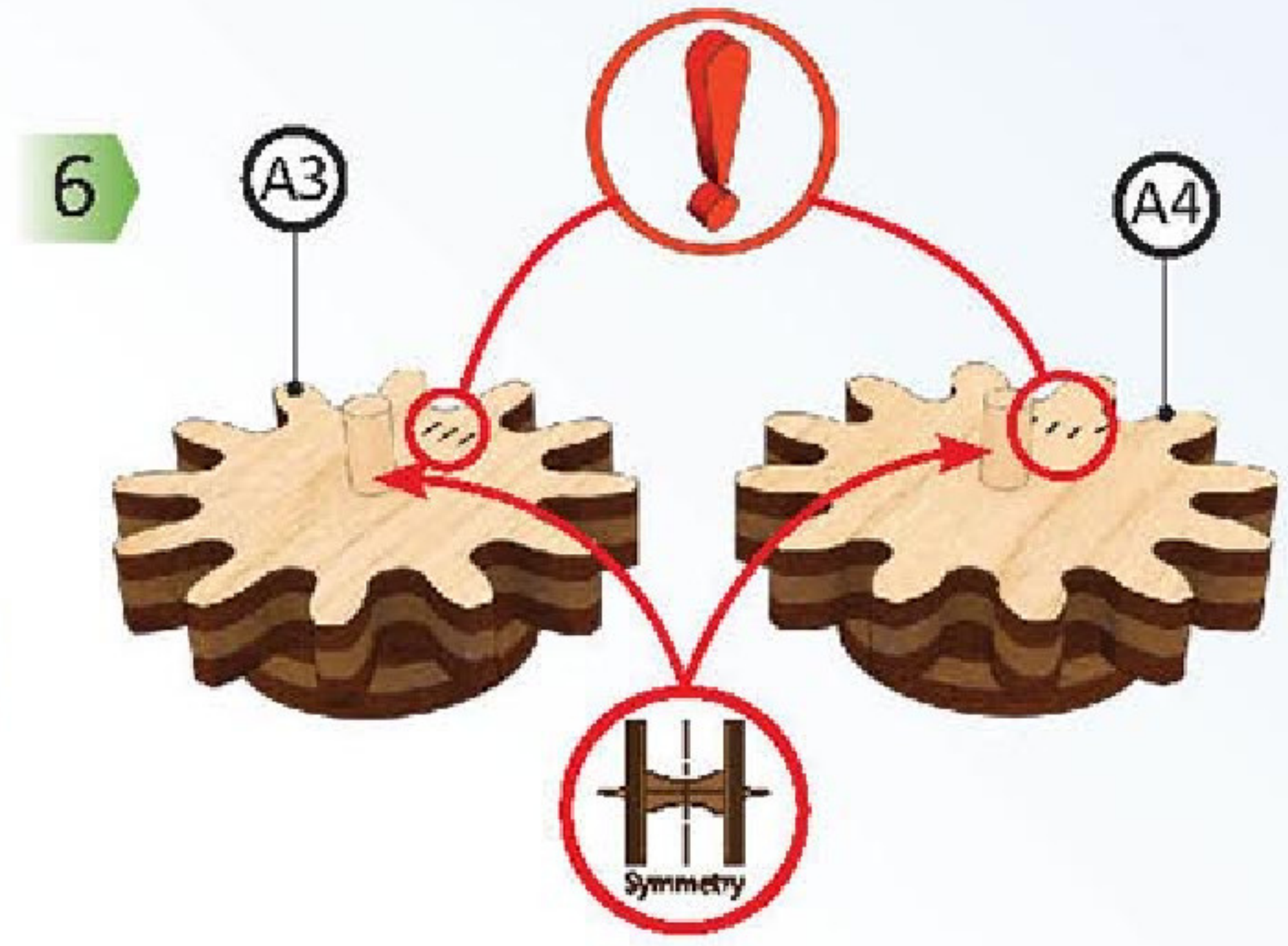
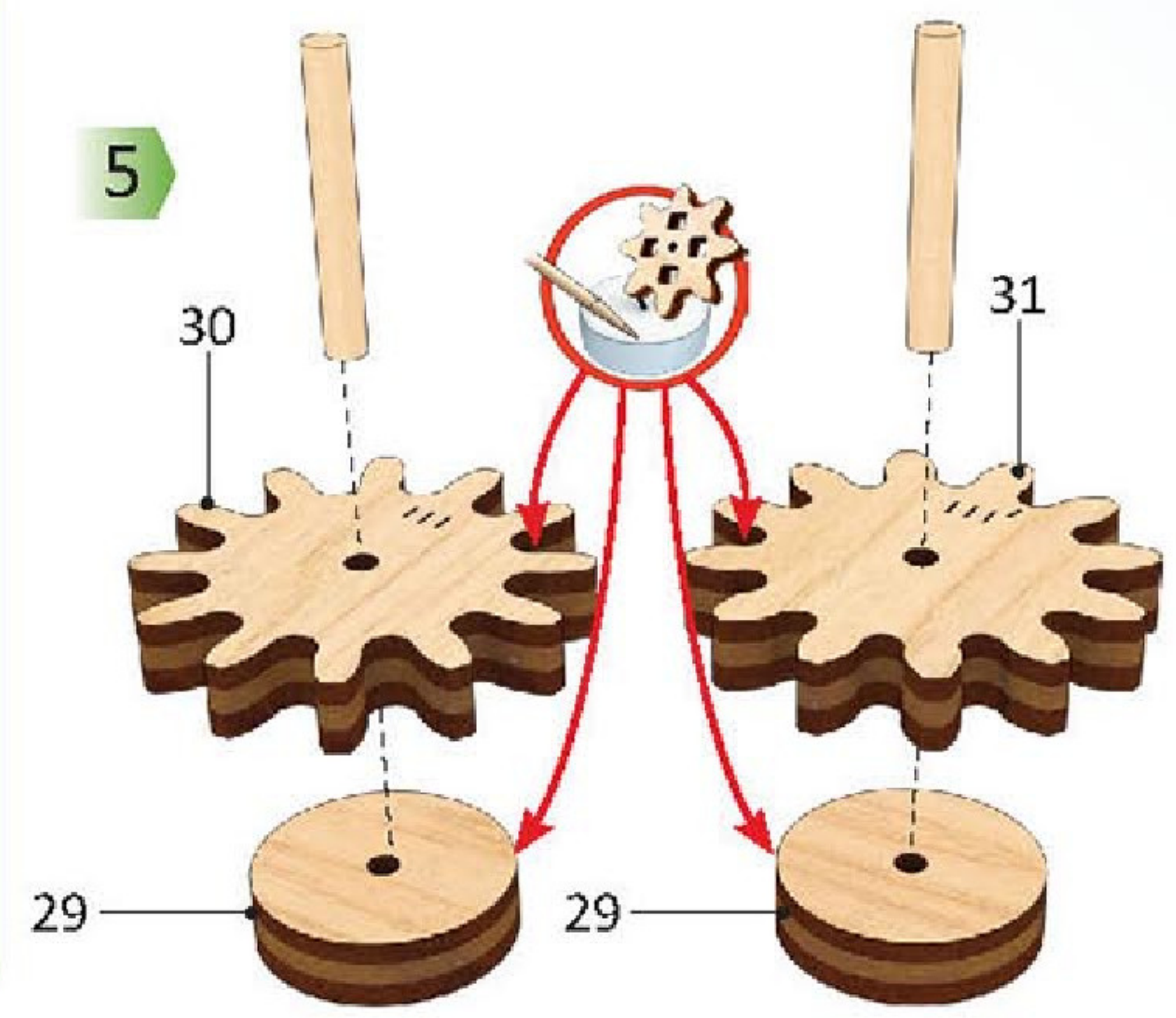
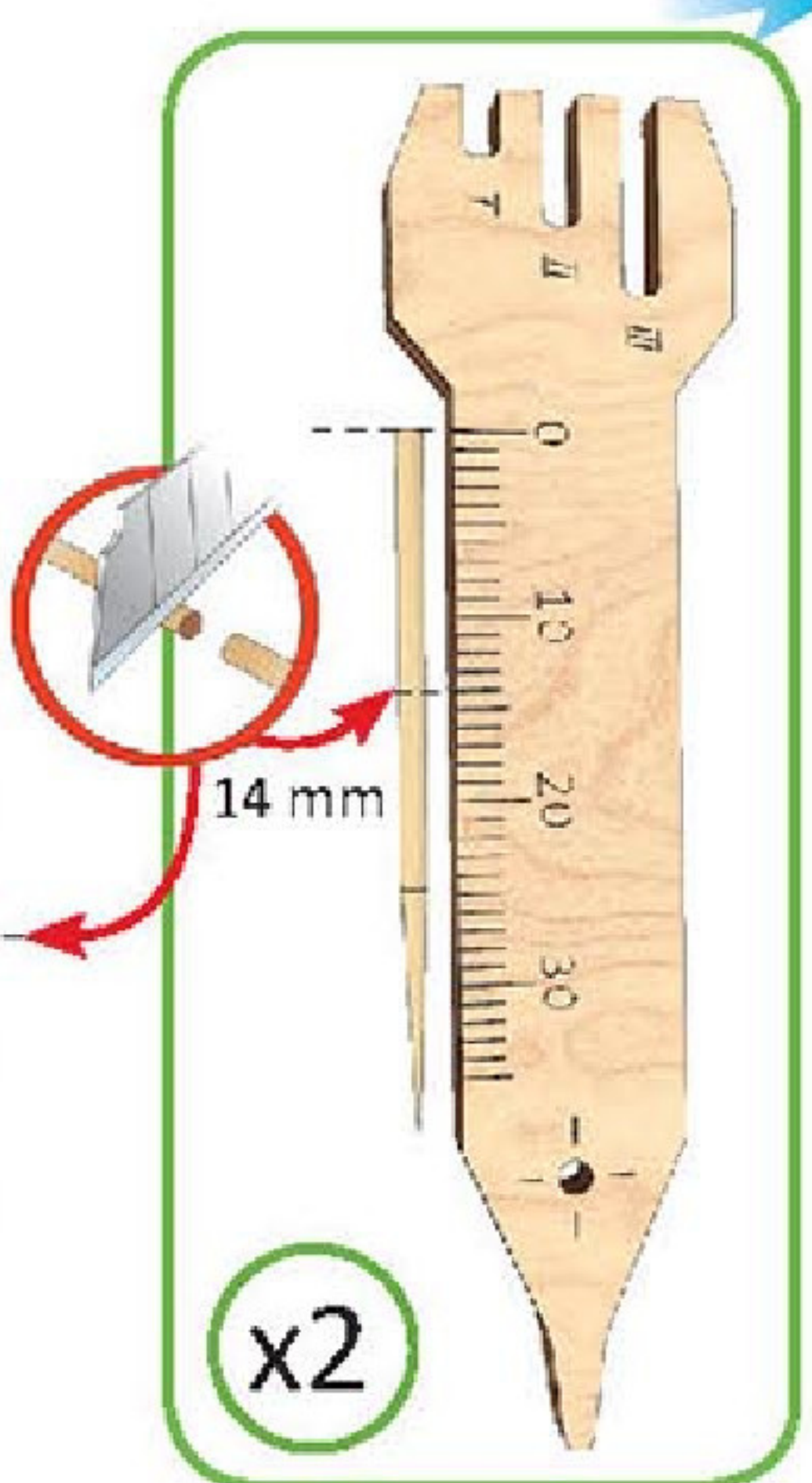
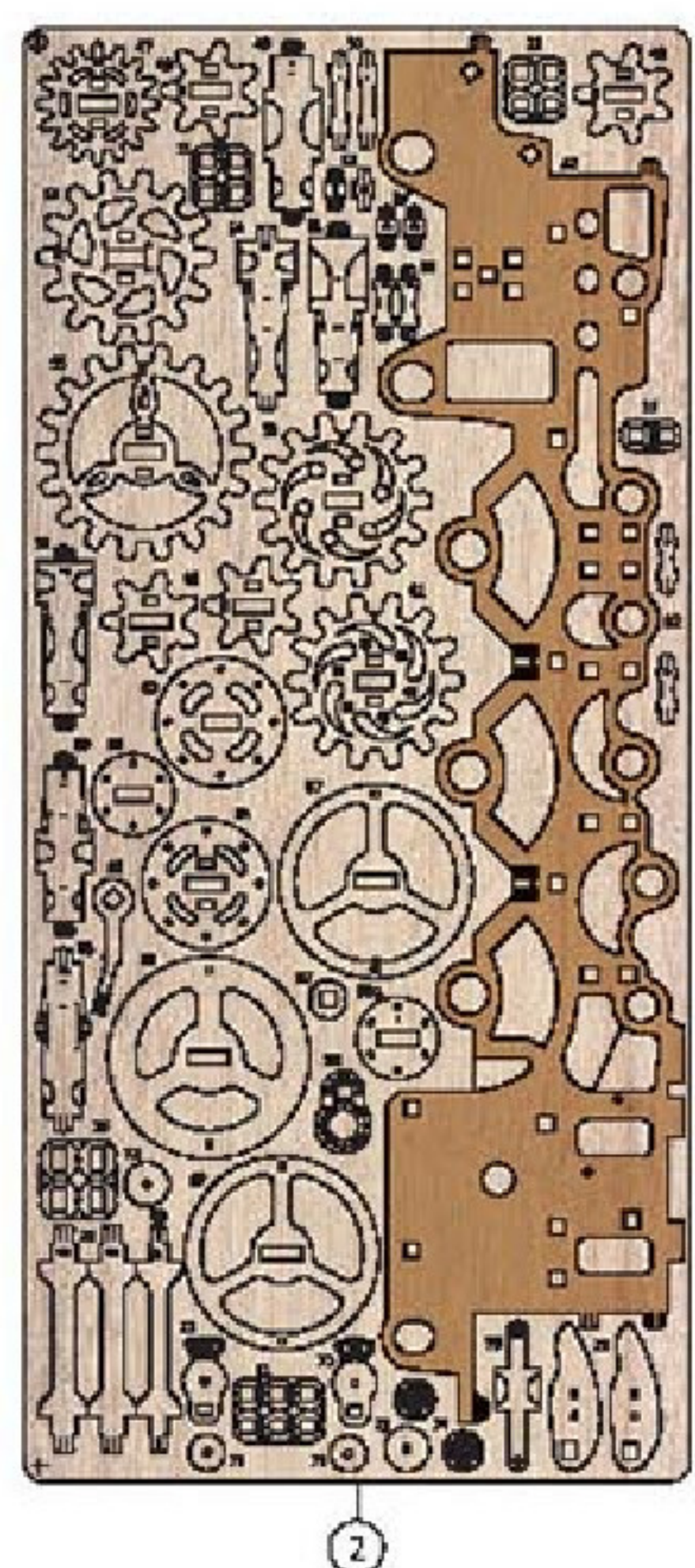
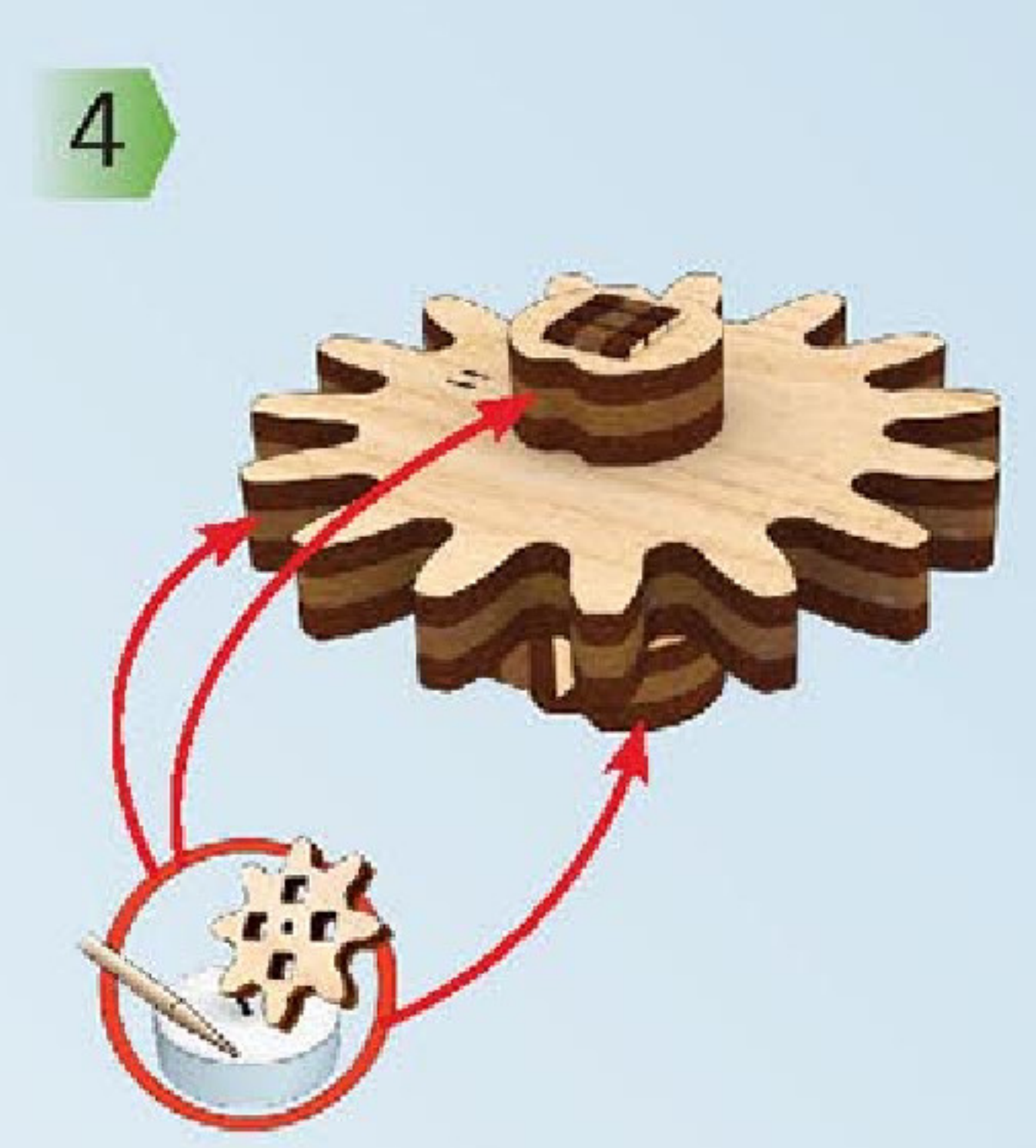
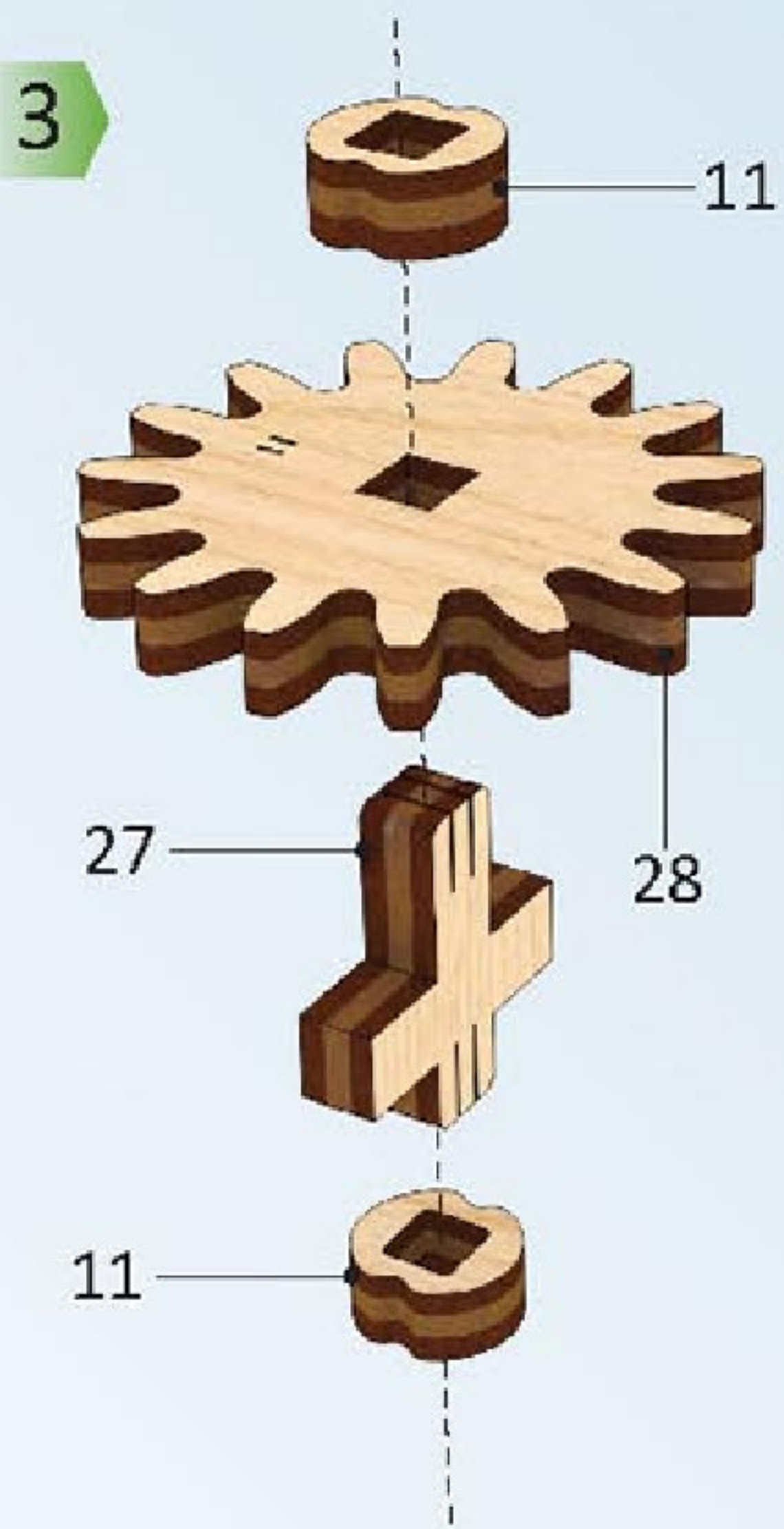
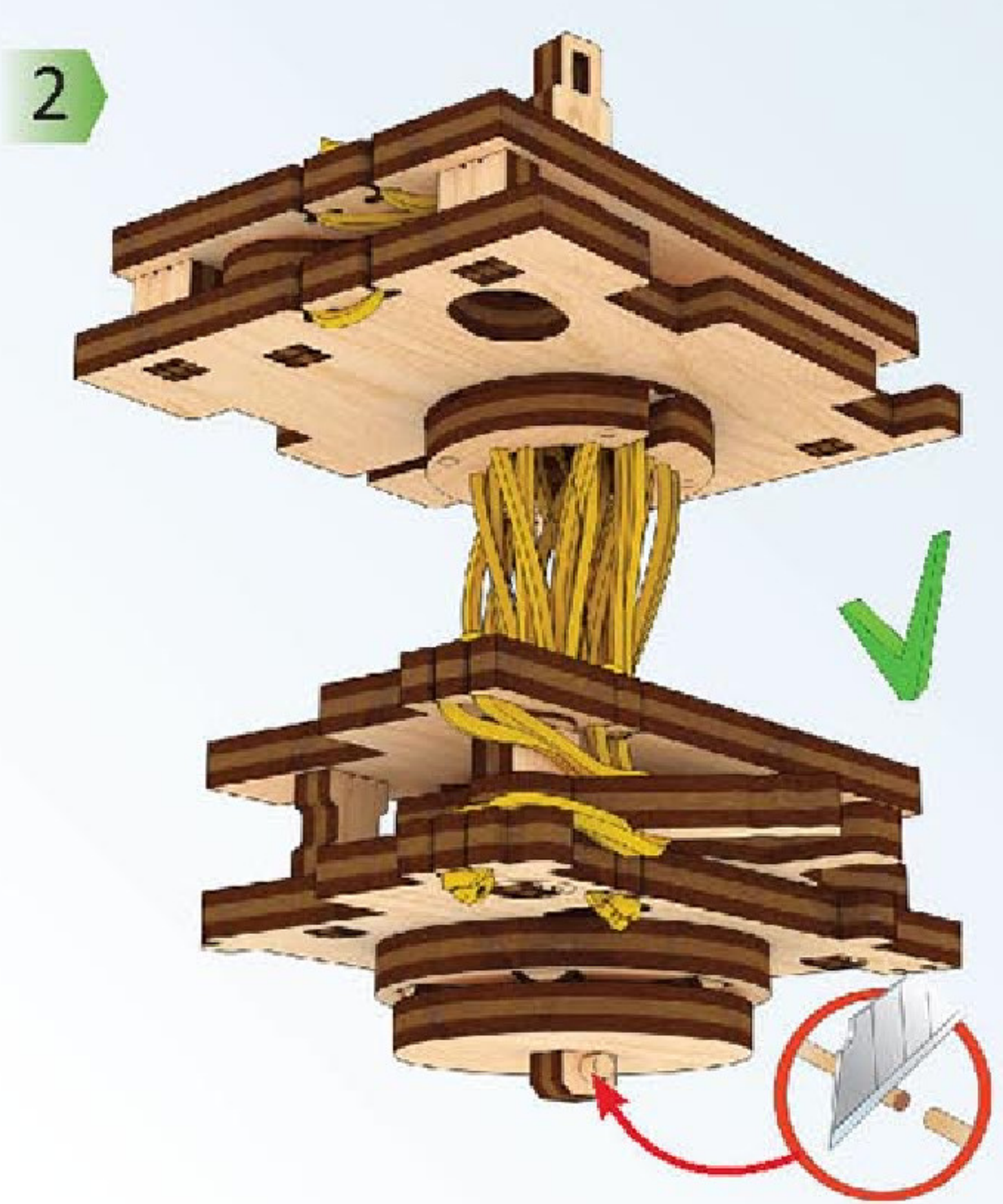
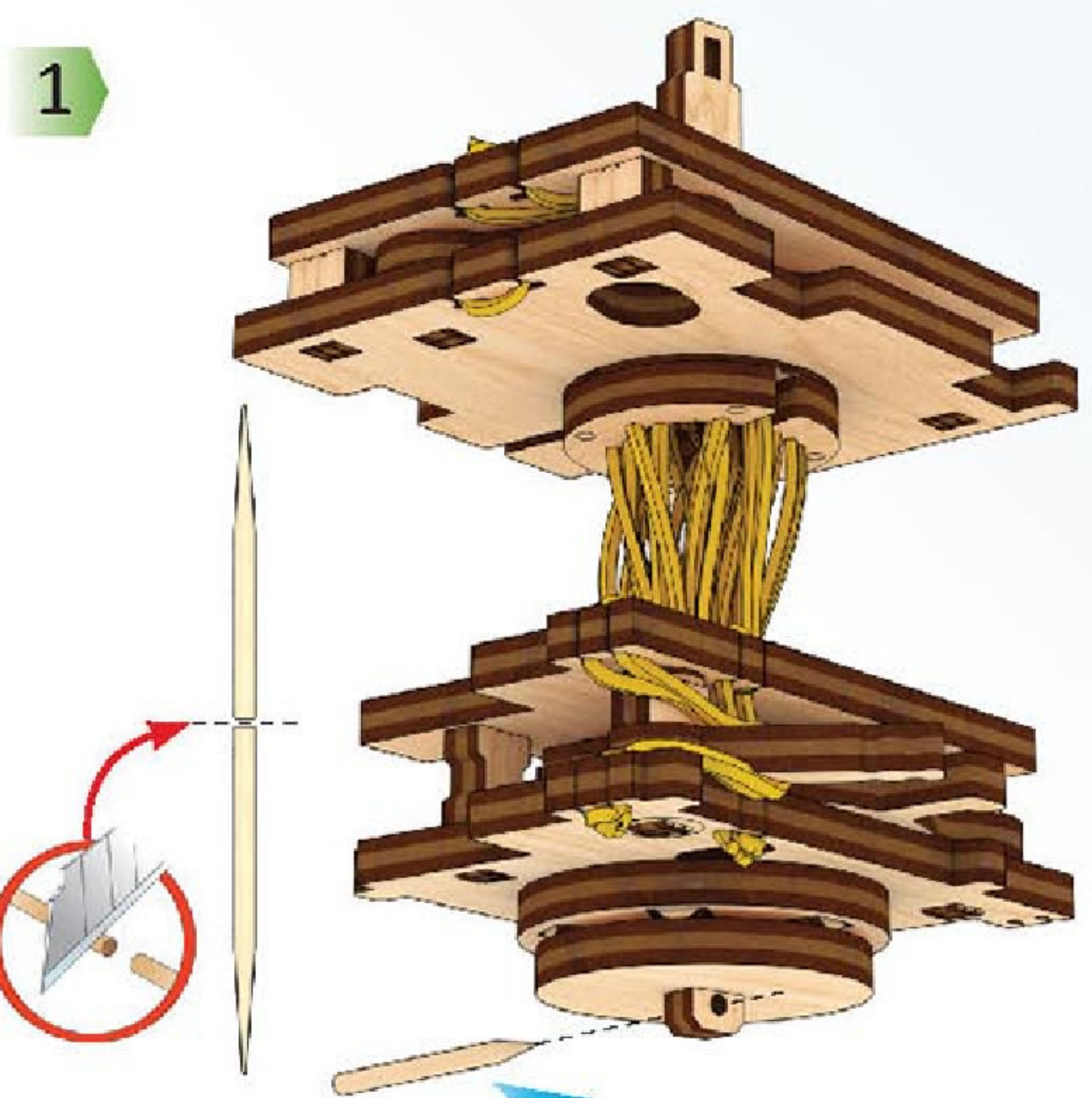
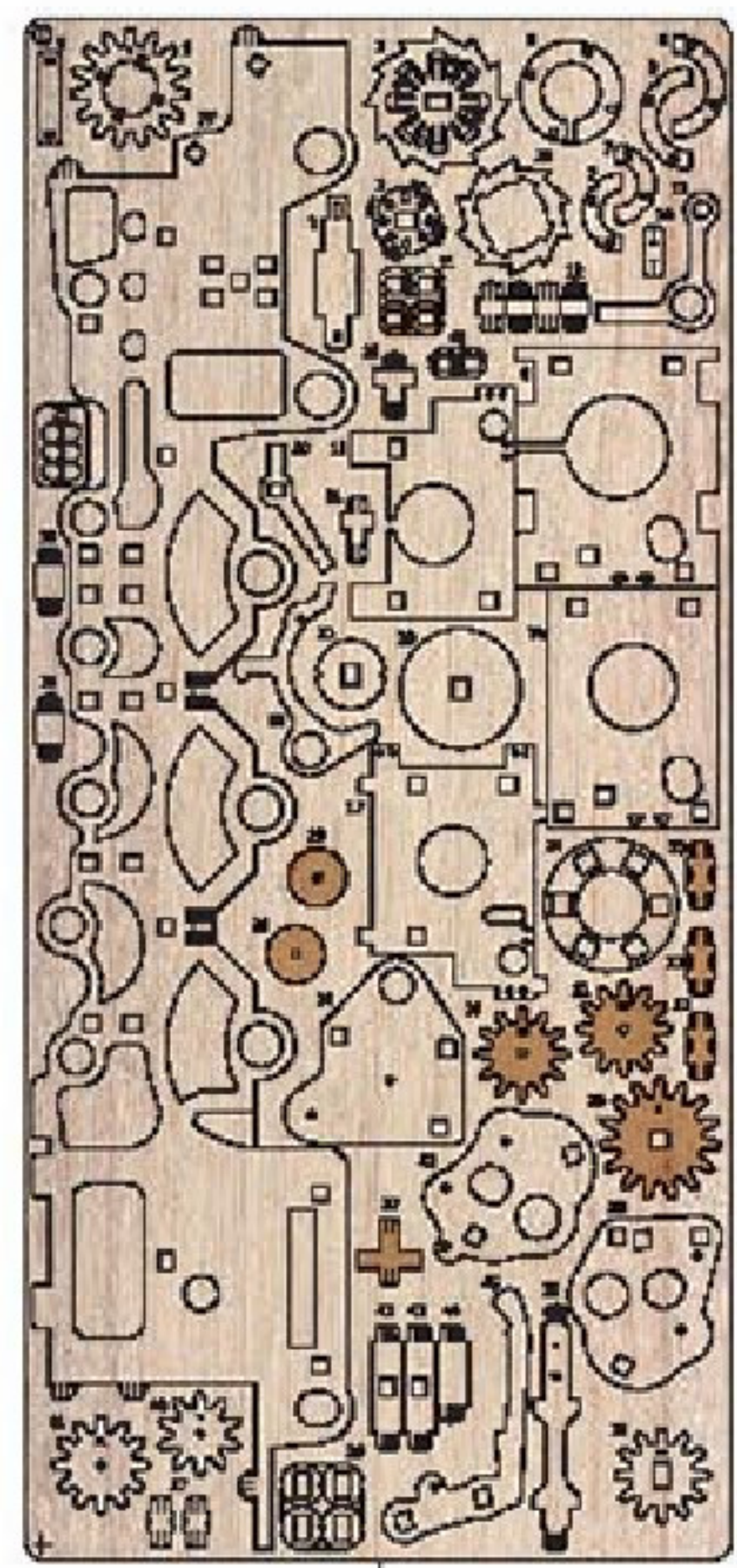

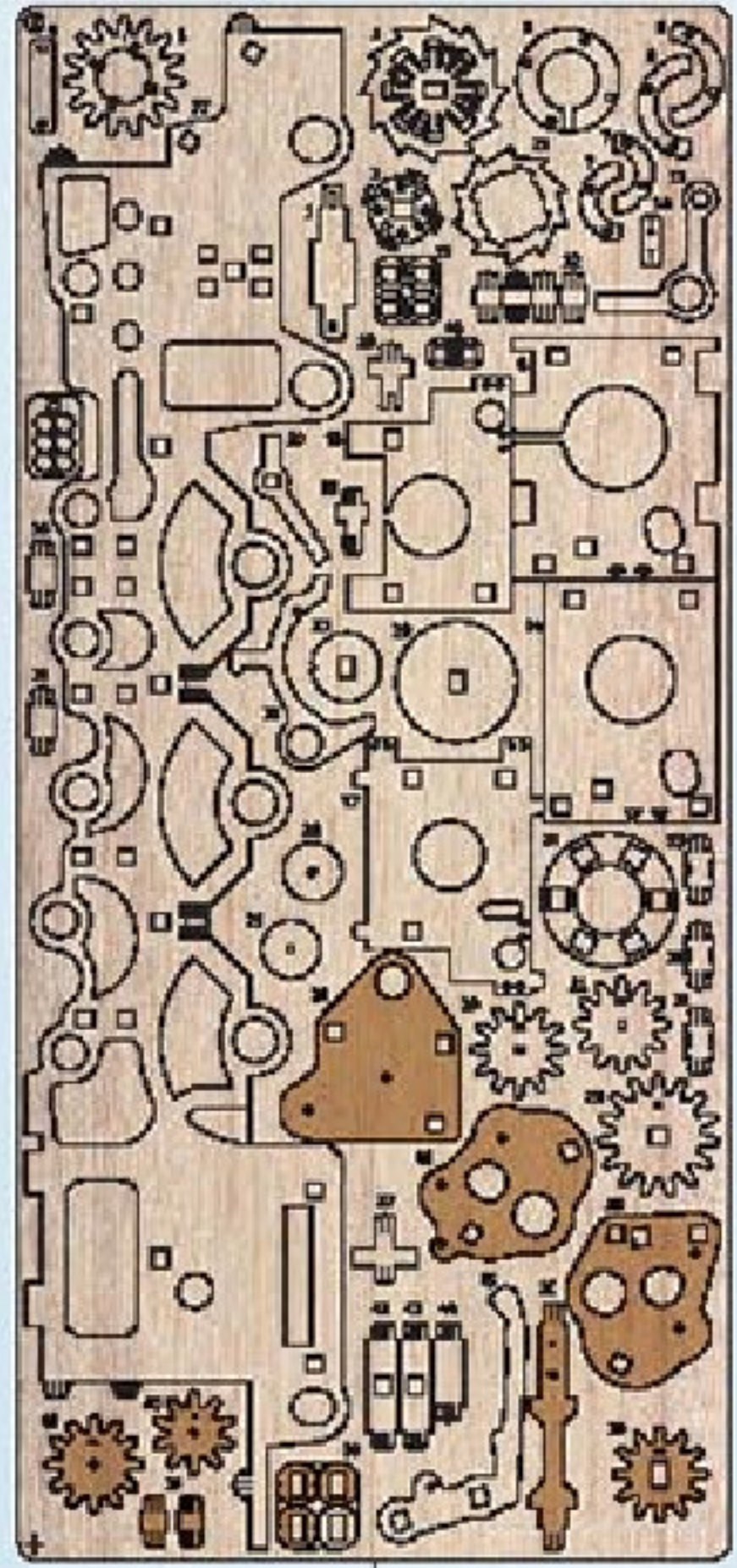

1

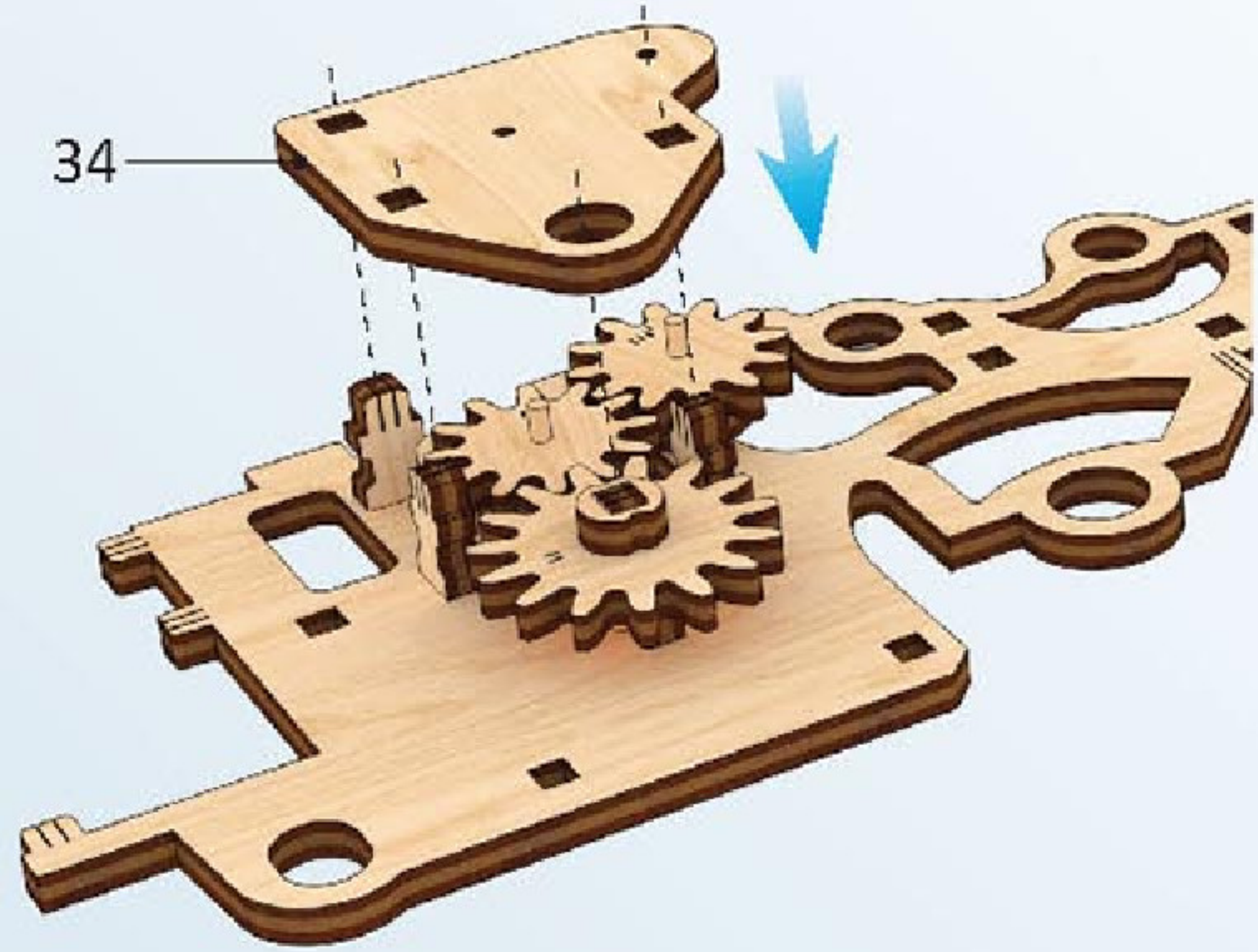

2

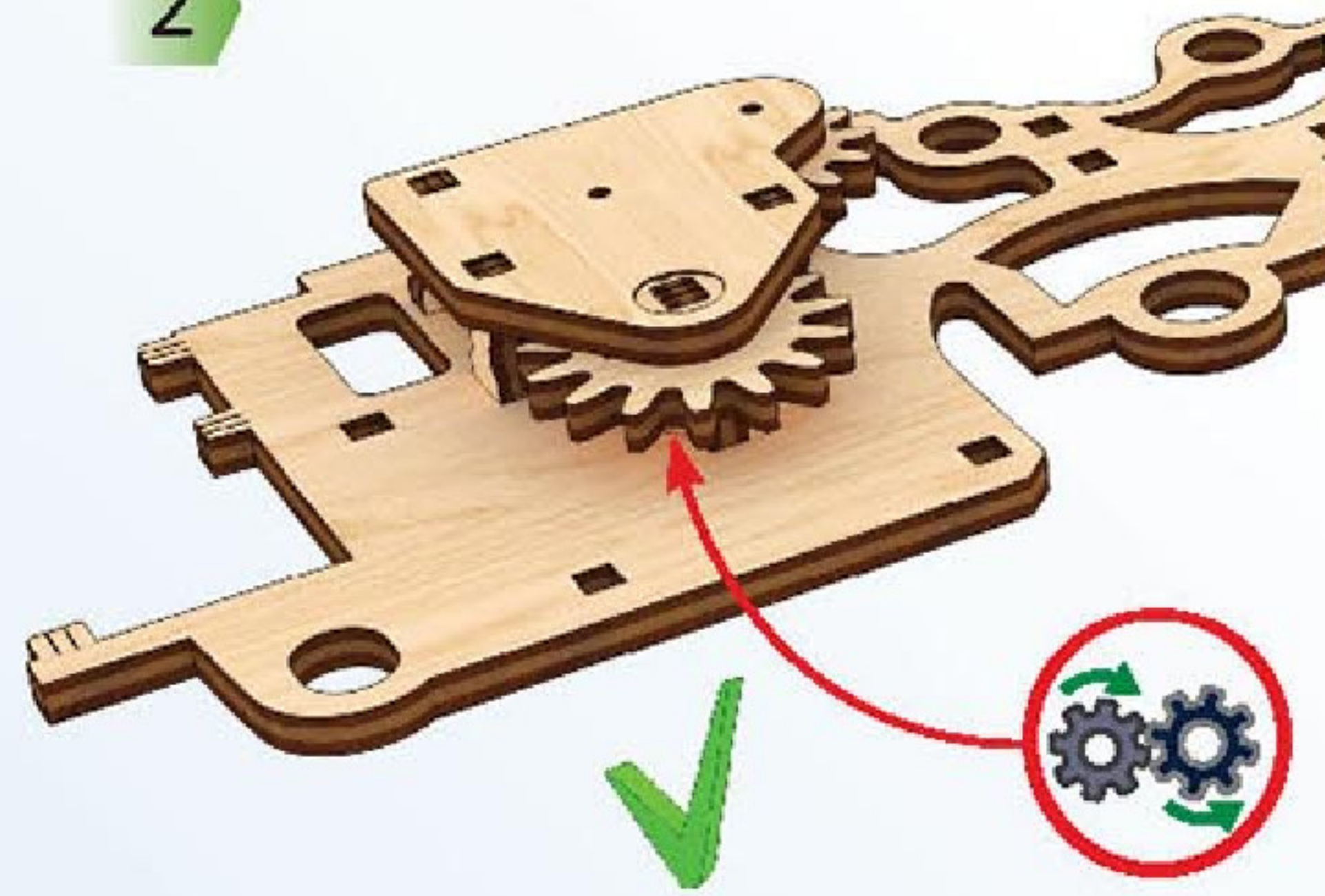

3

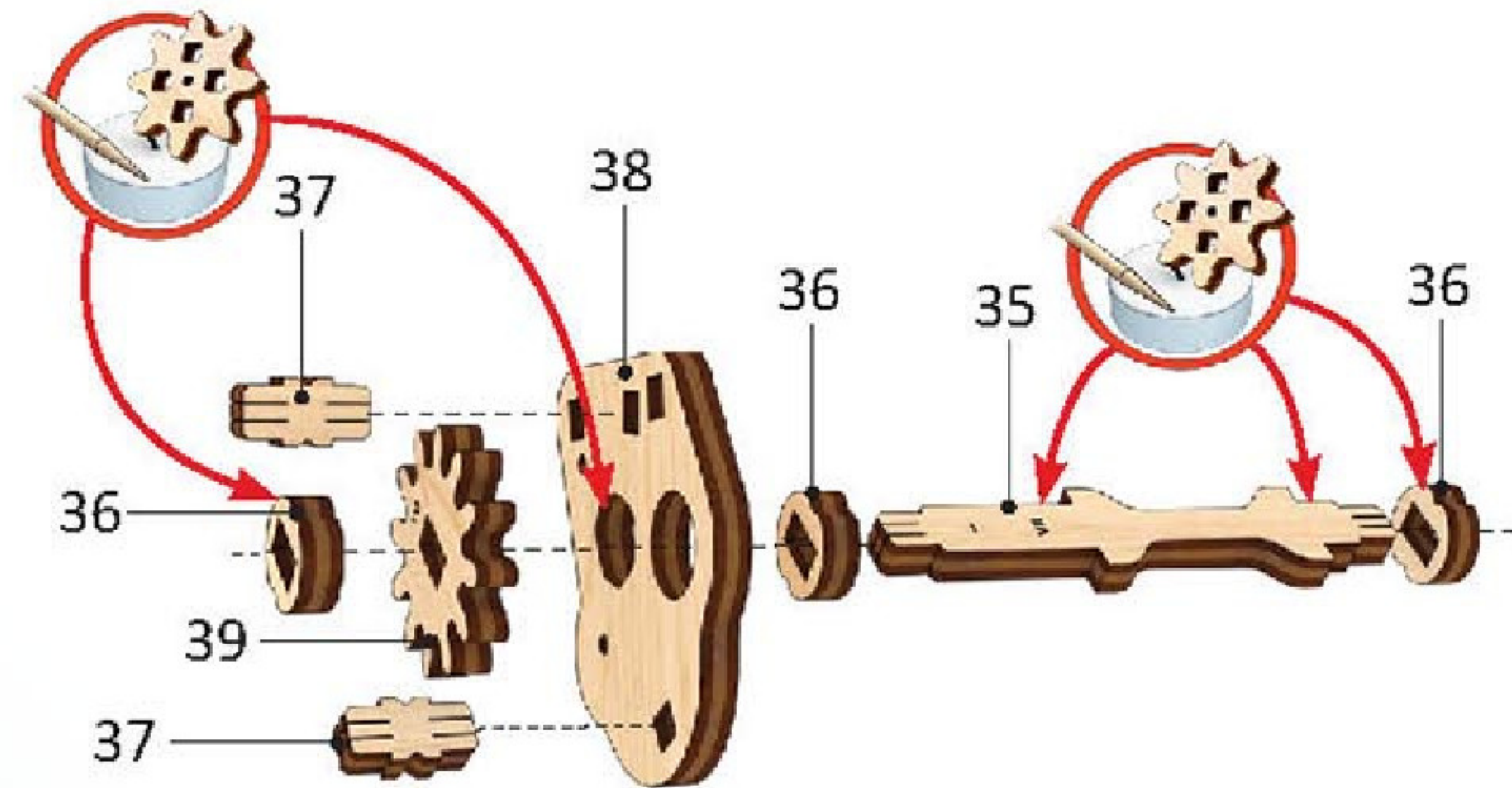

4



5

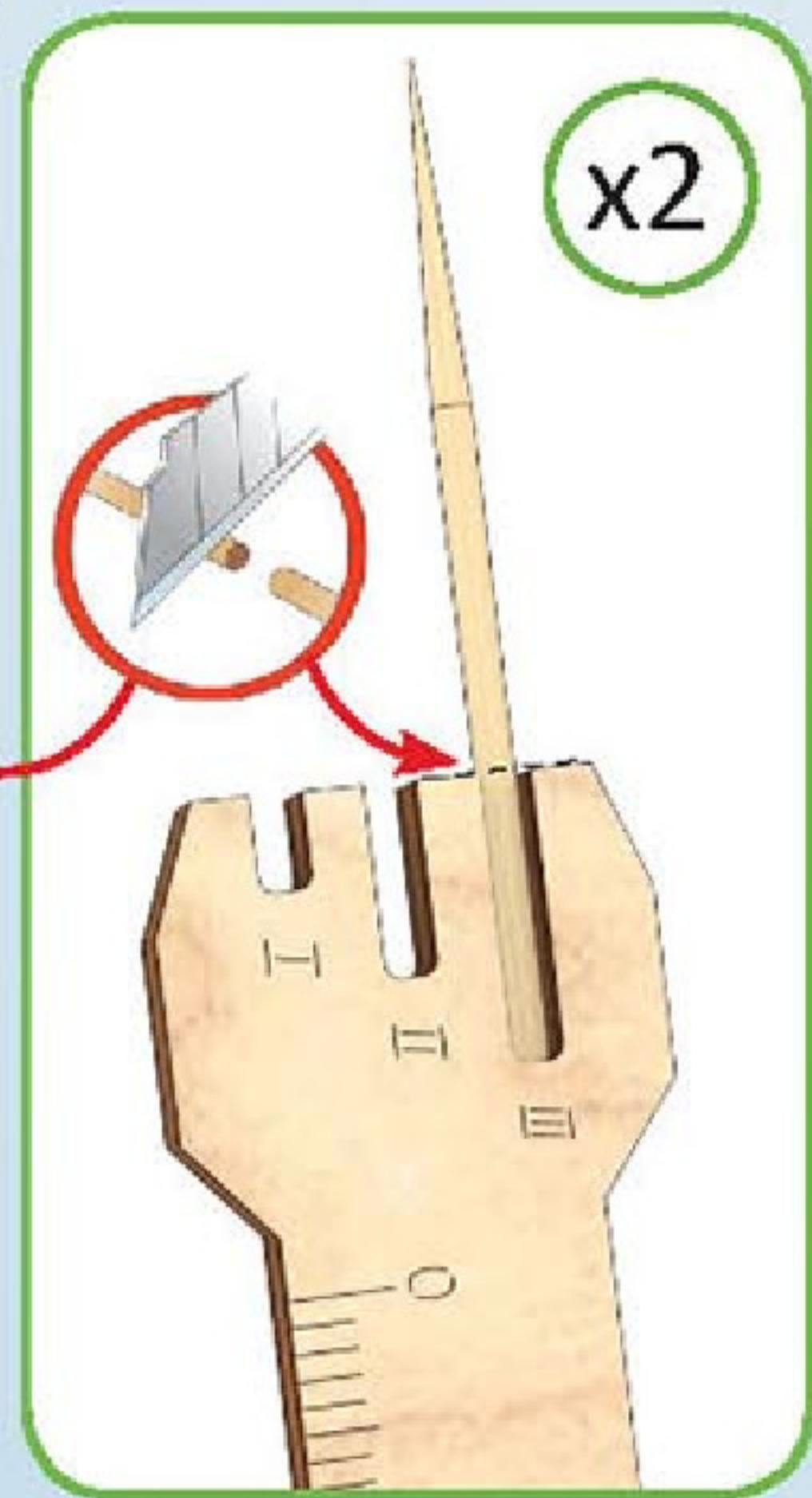

6

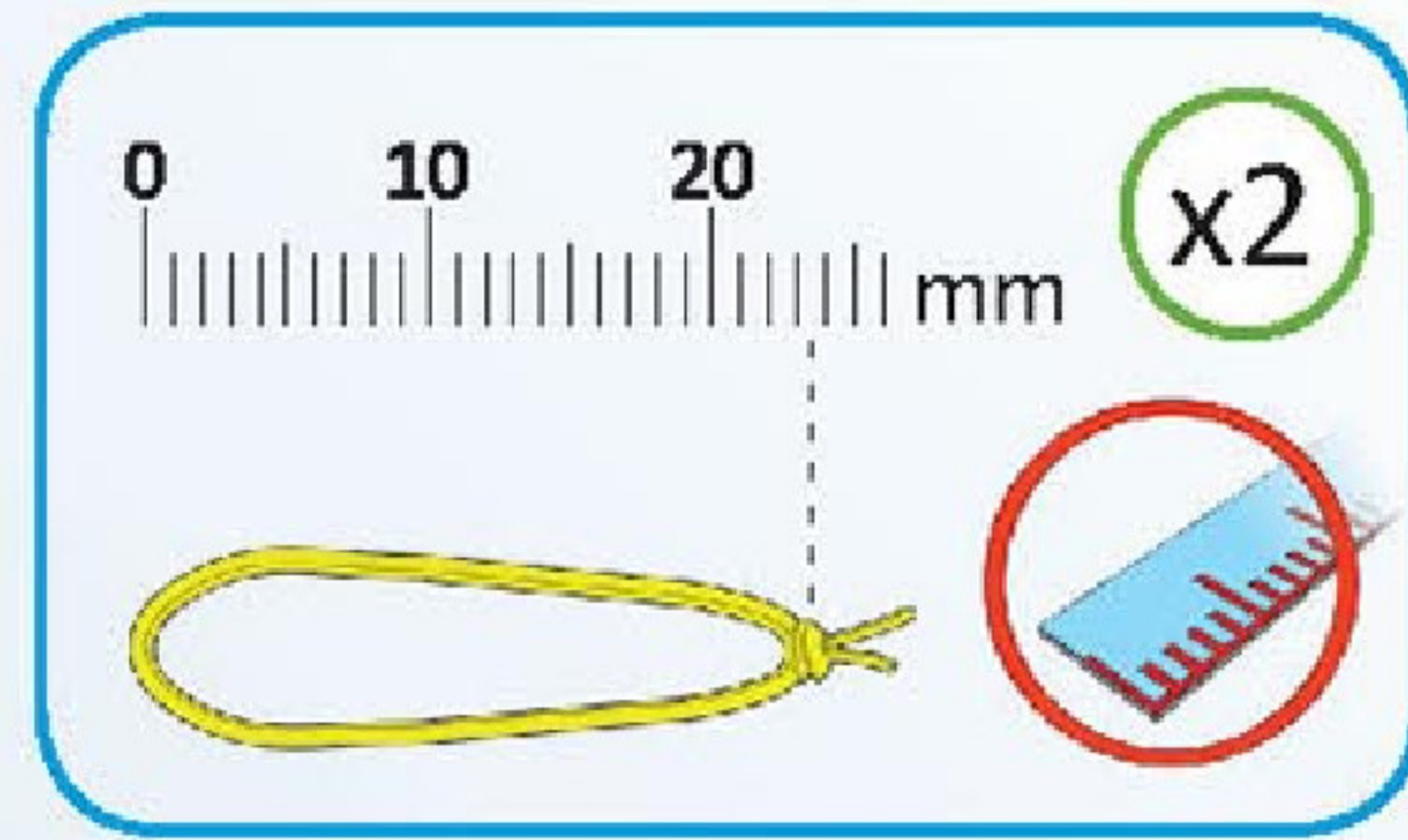

7

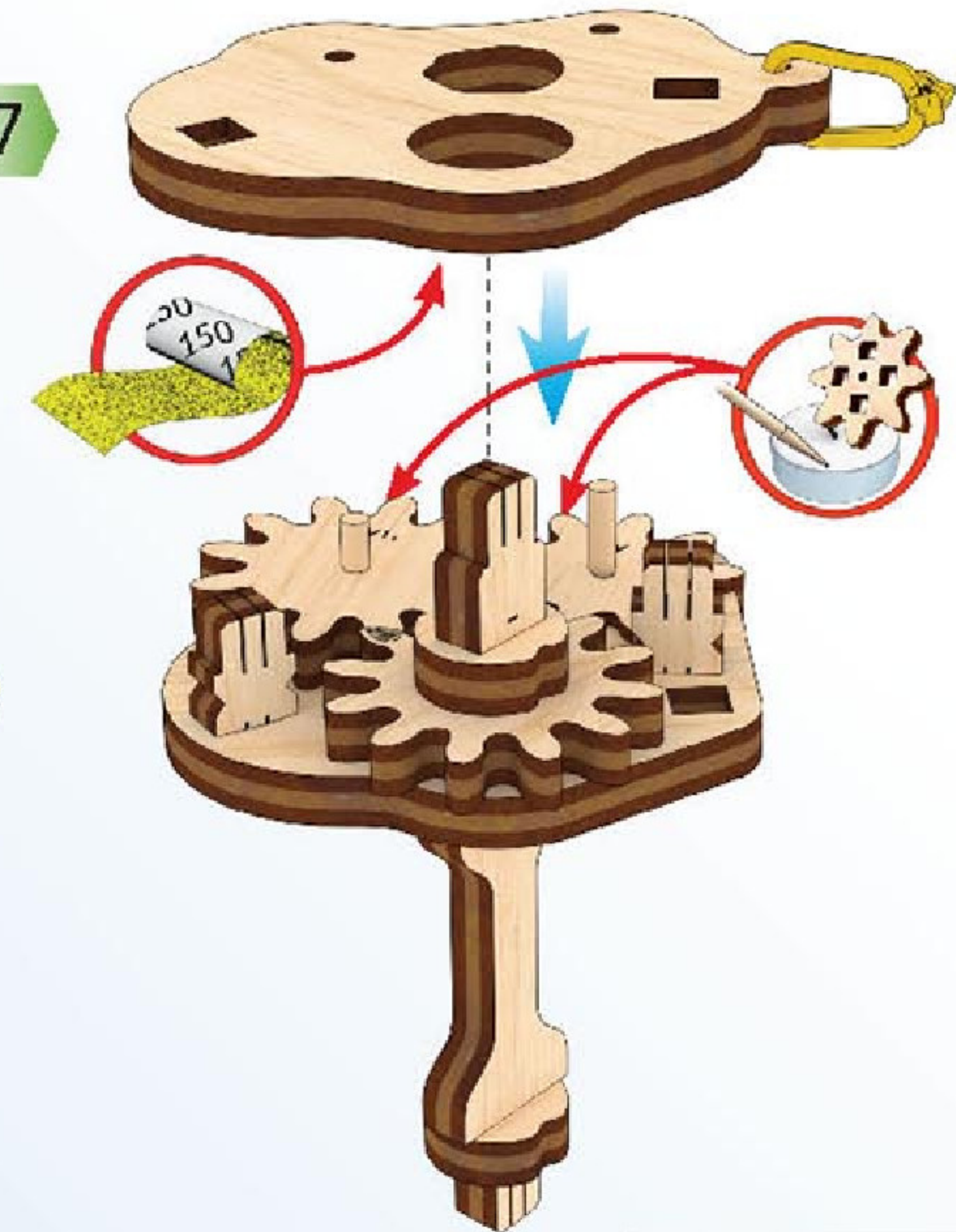

8

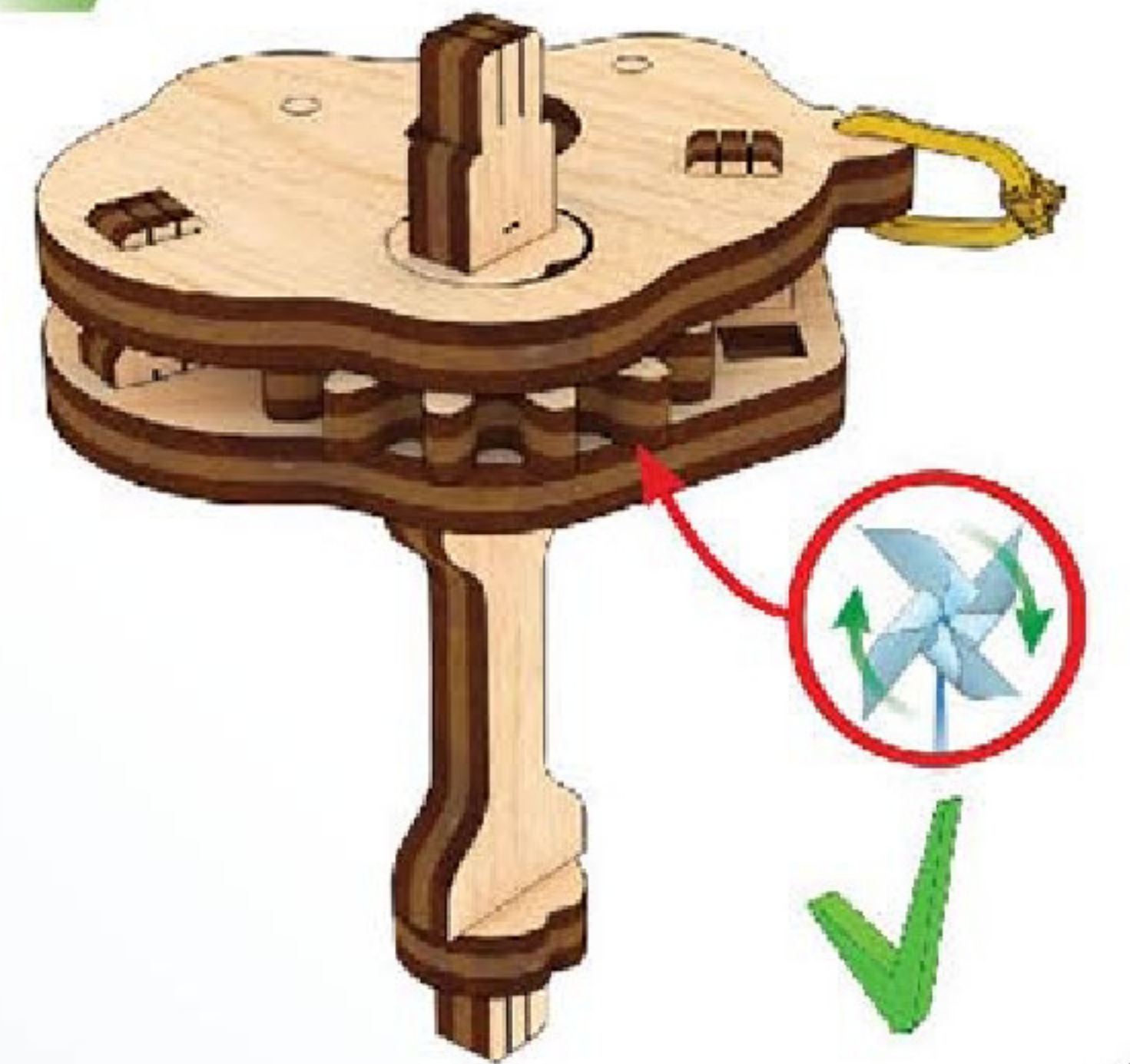

10

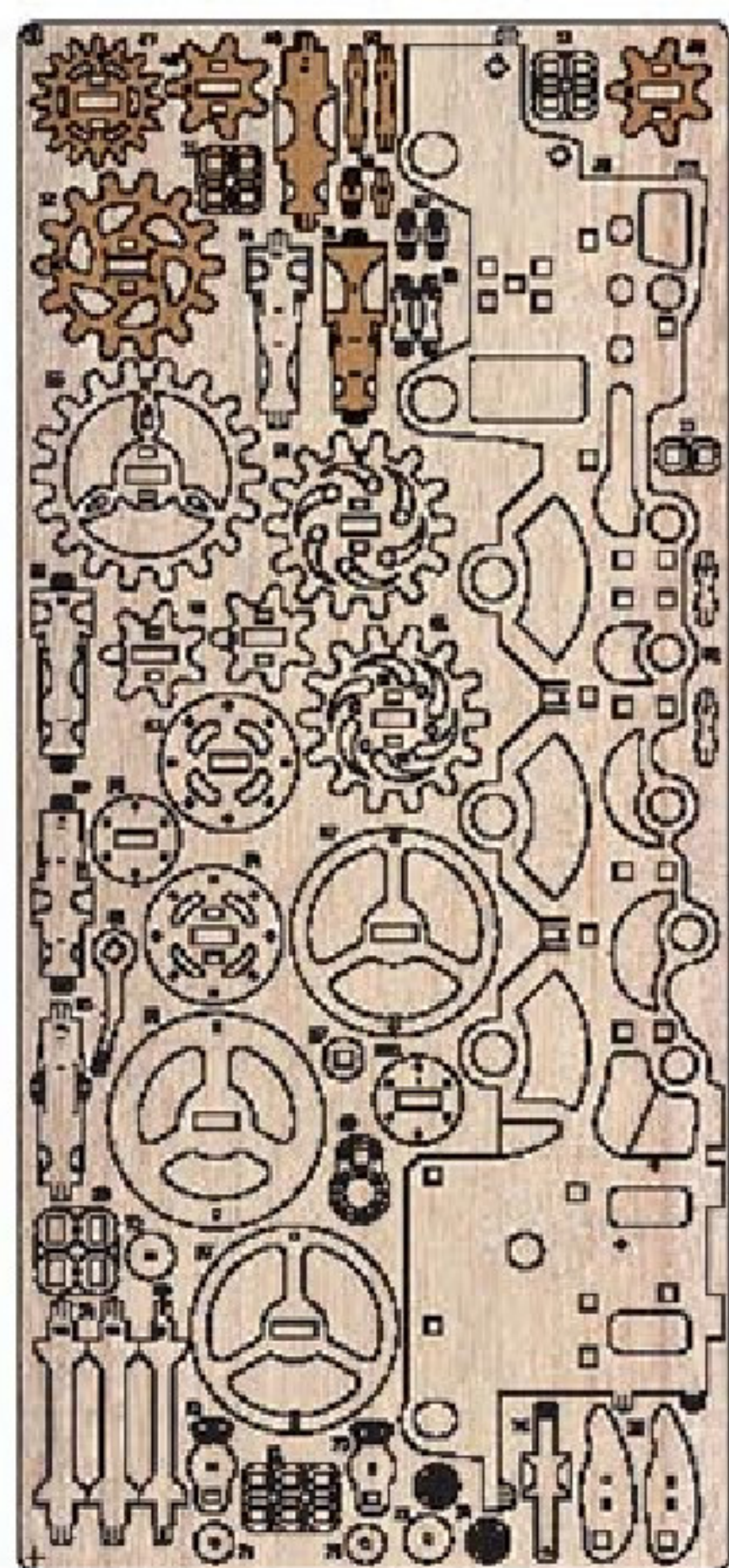
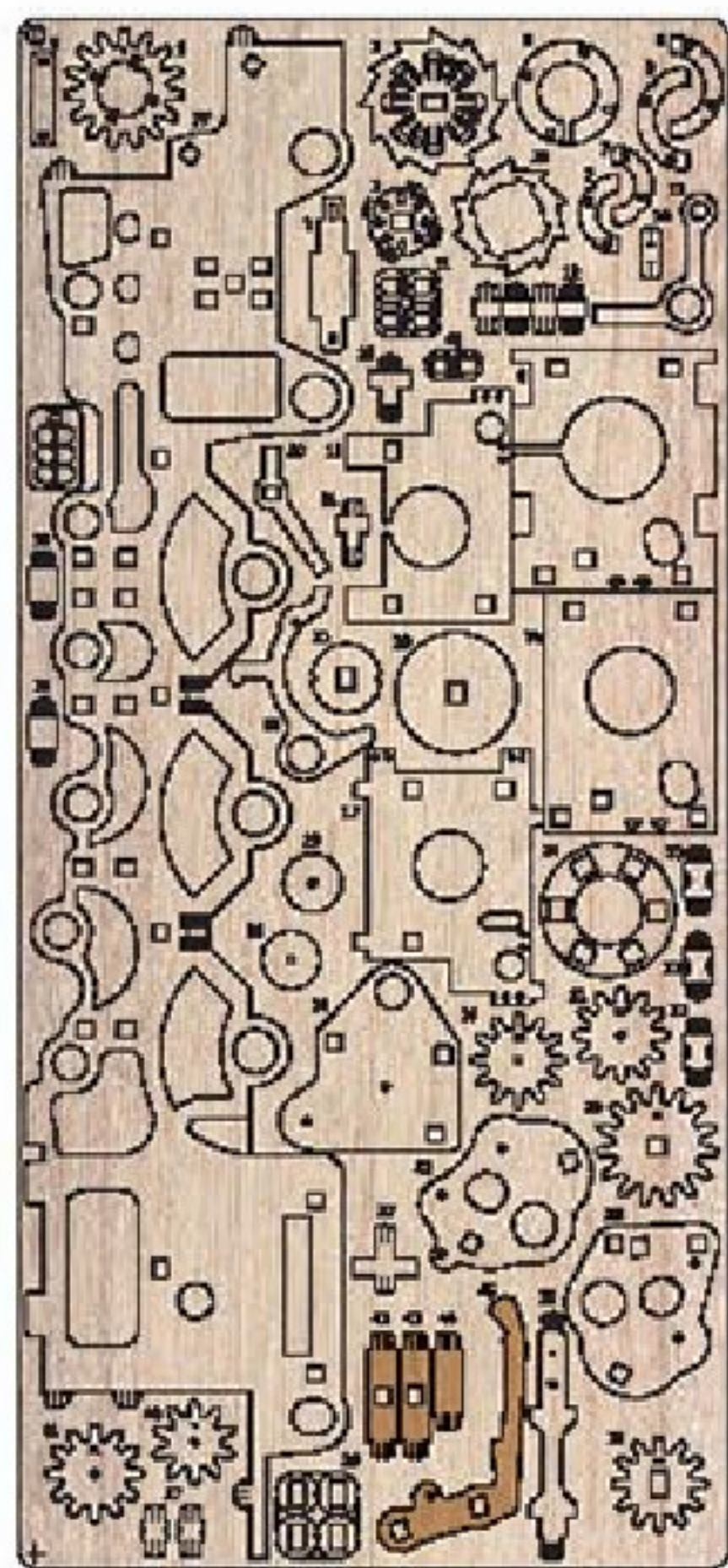

1

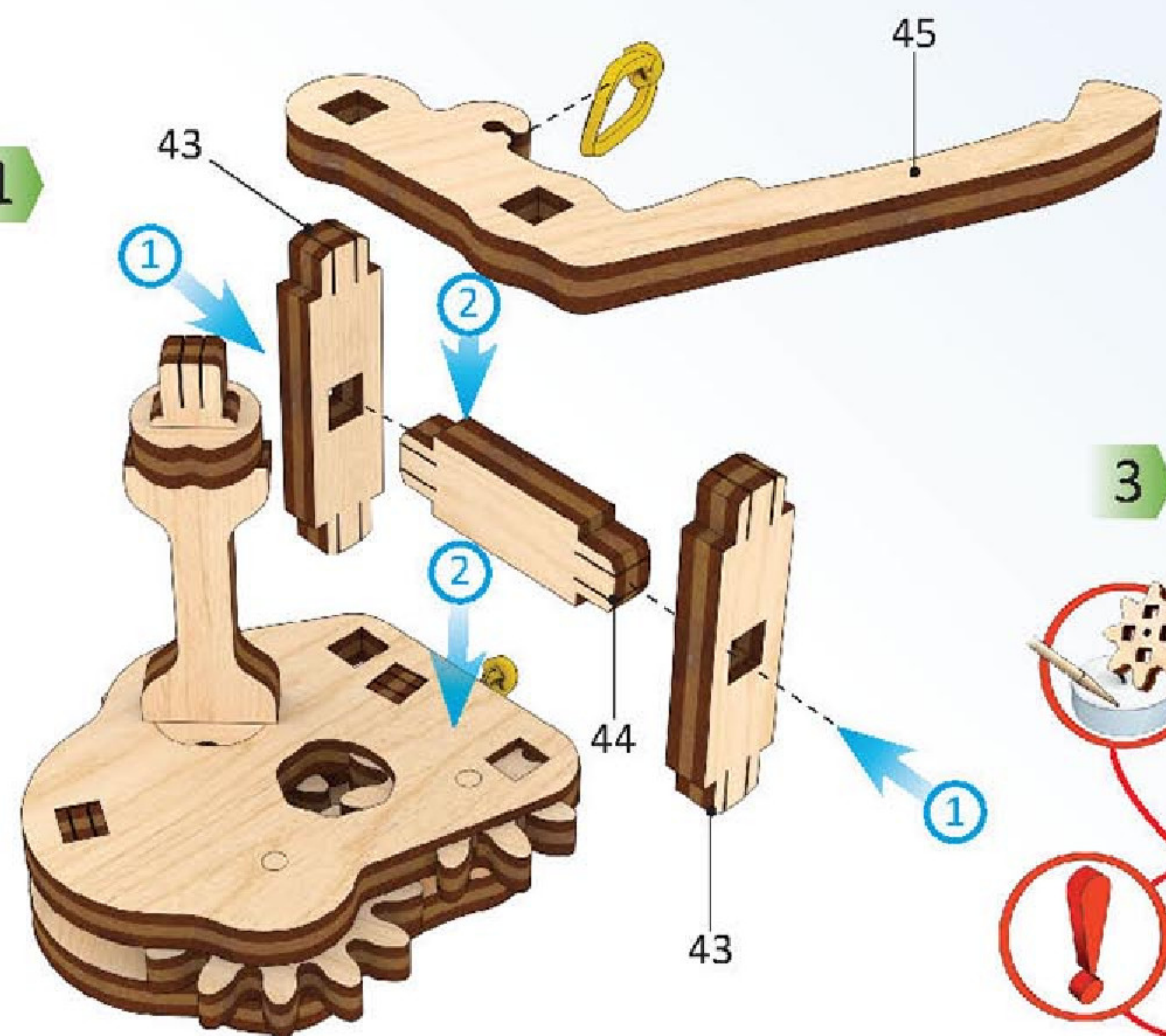

2

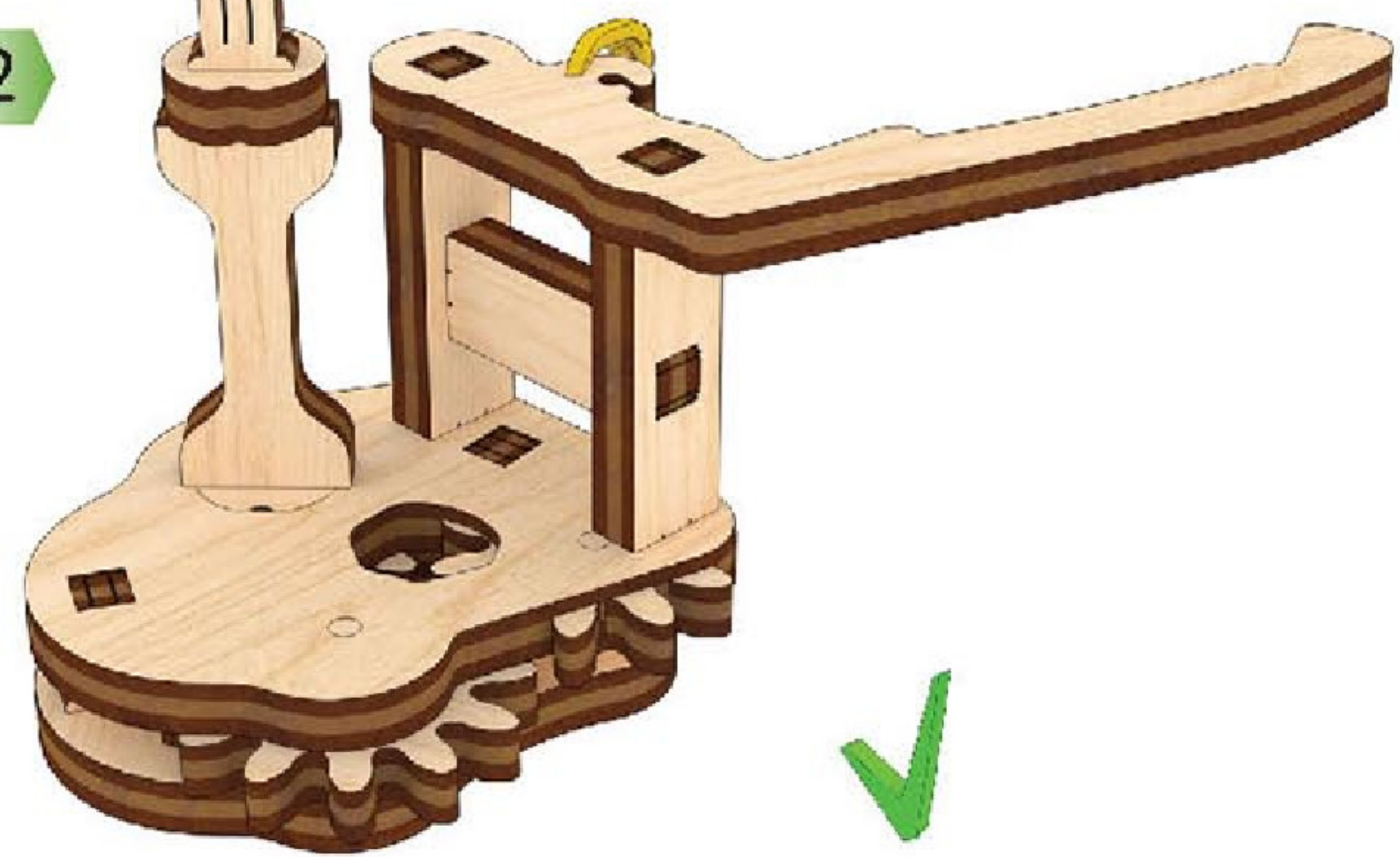

3

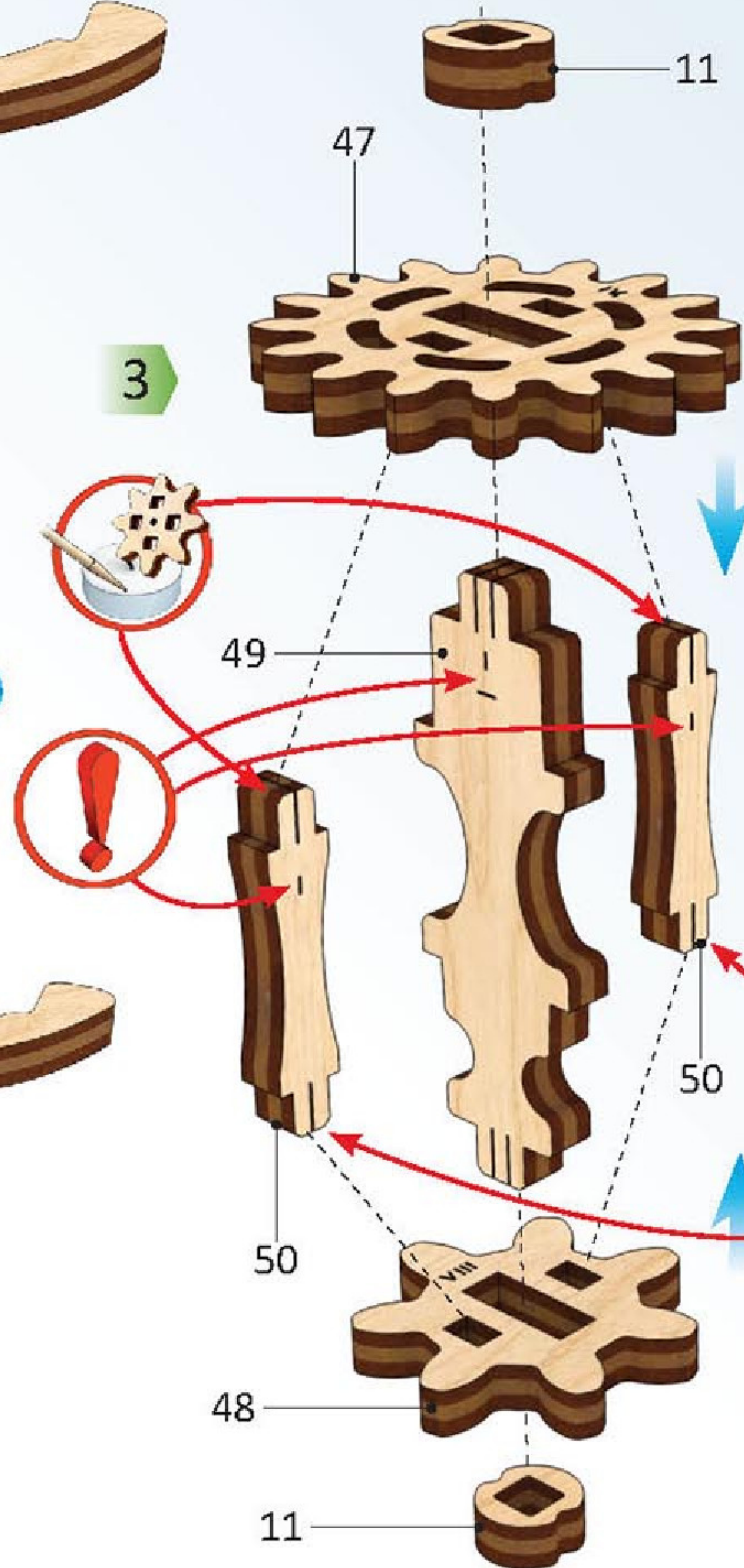

4

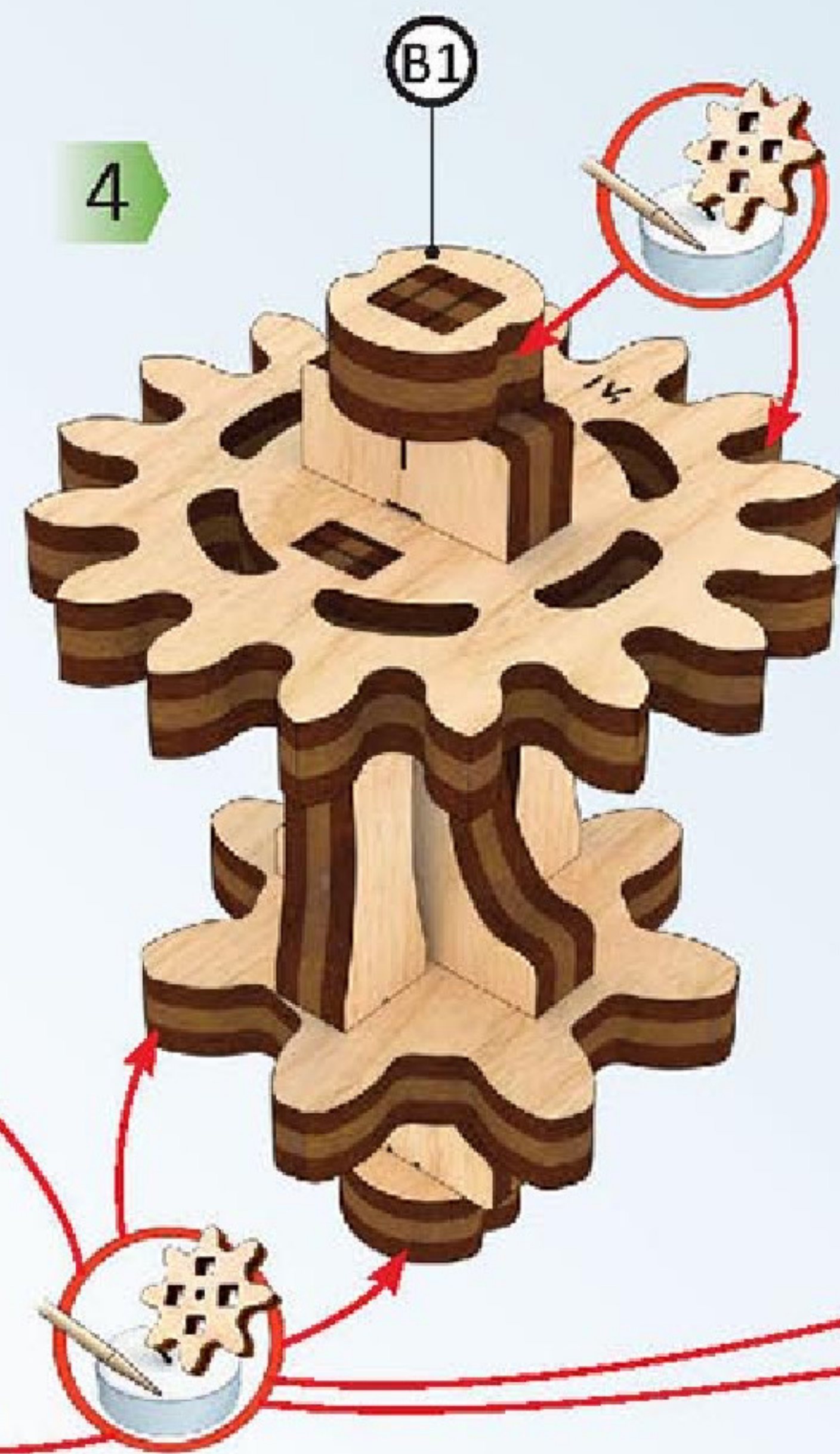

5

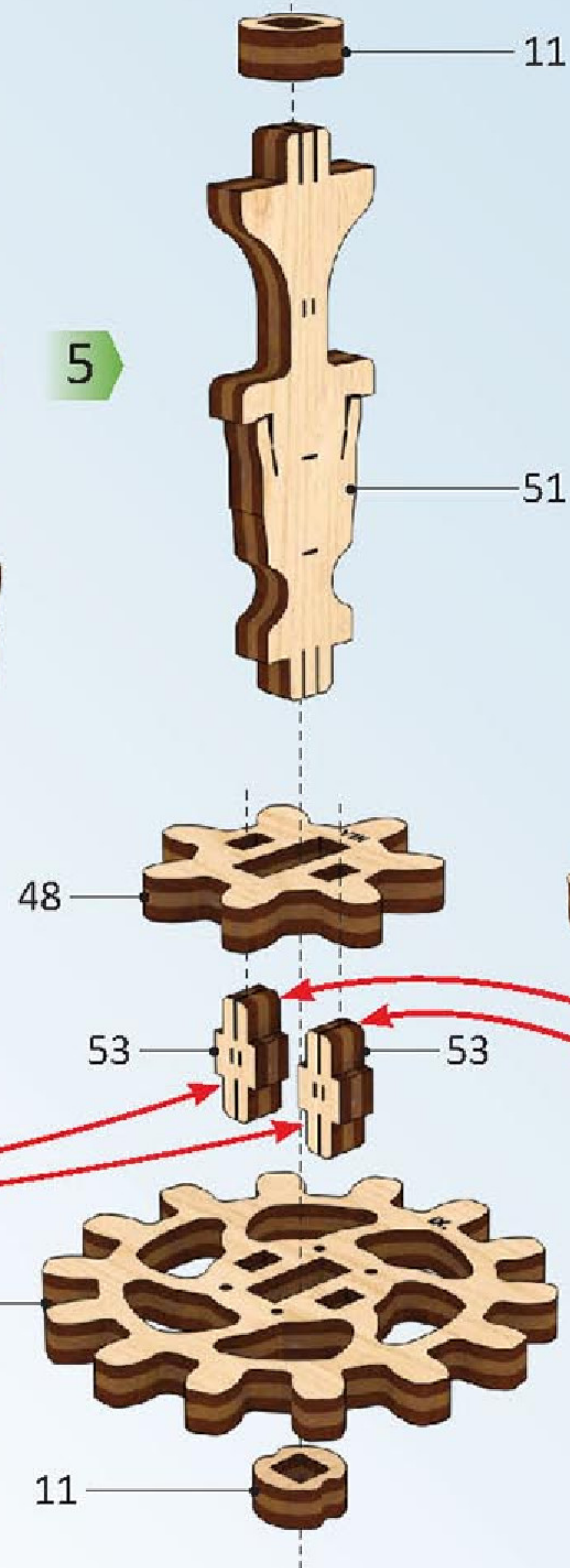

6





1

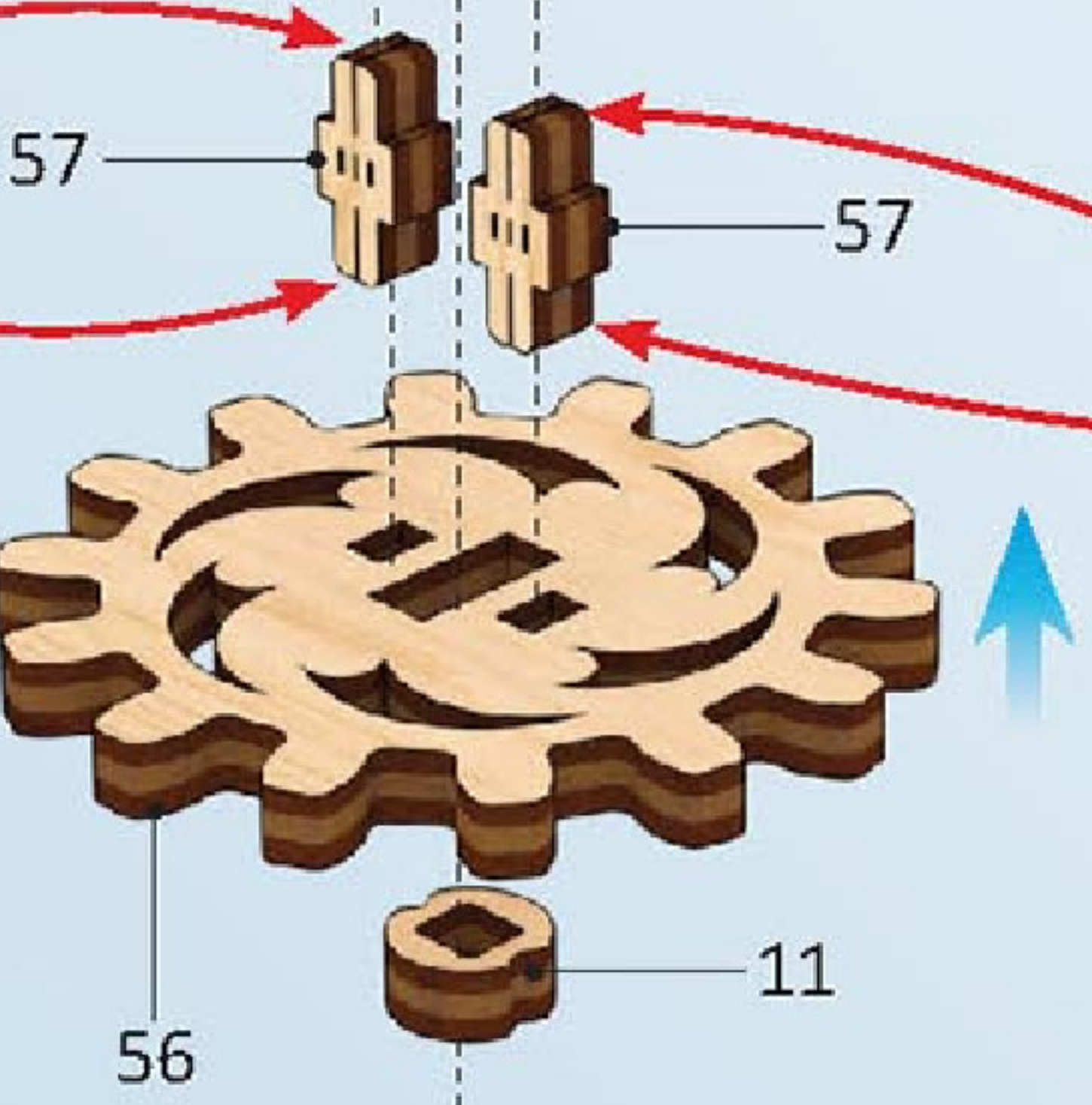
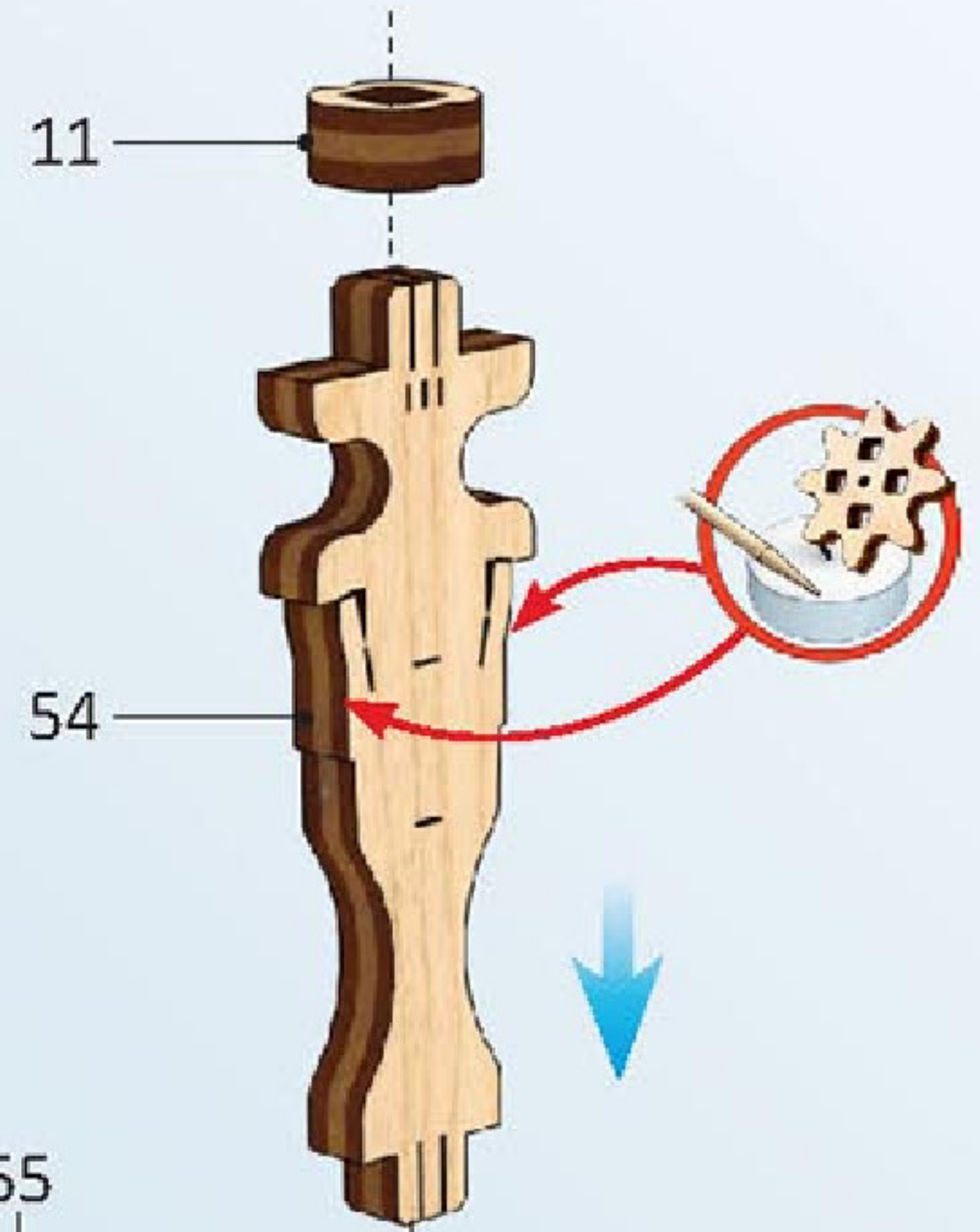

2

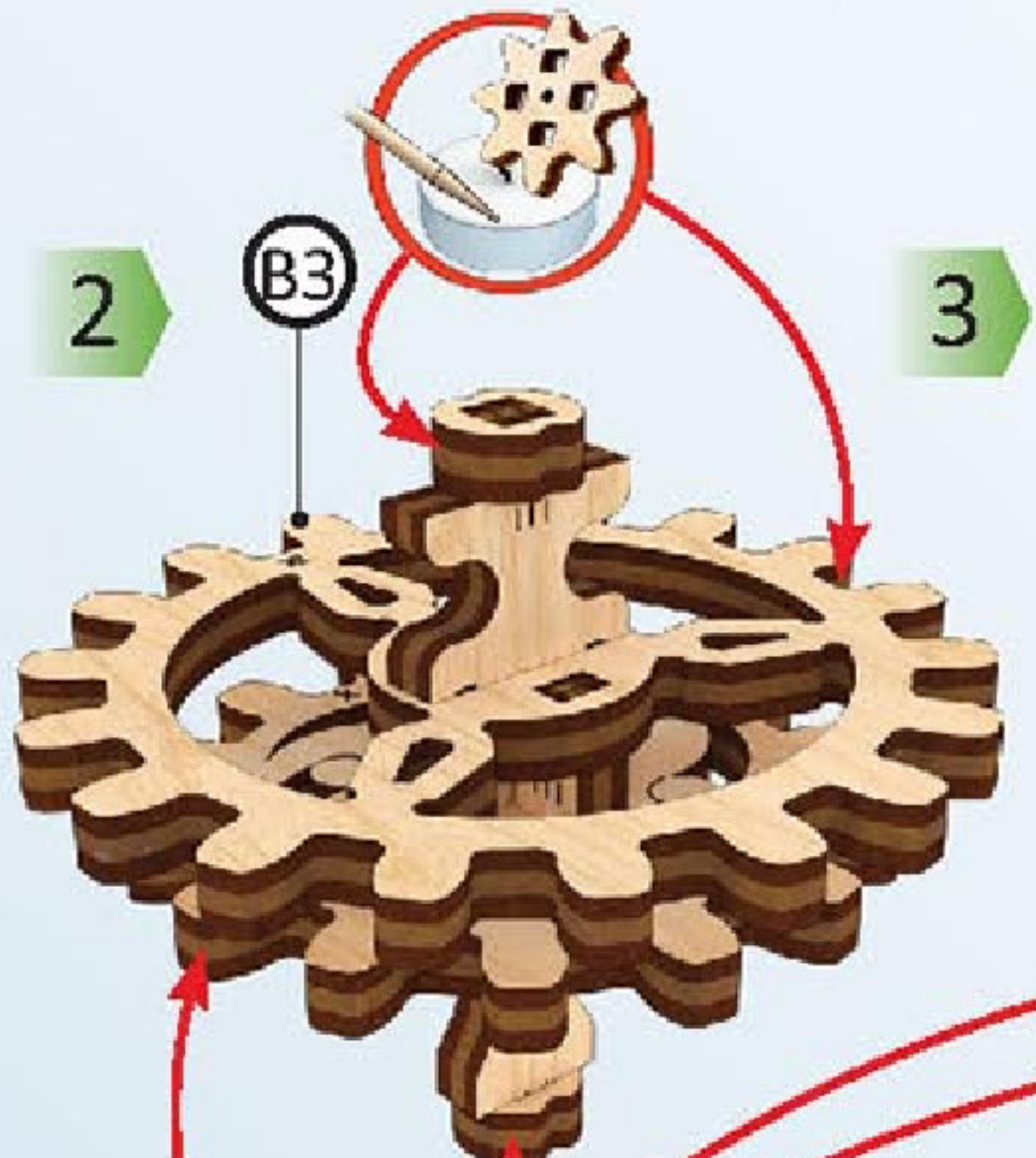

3

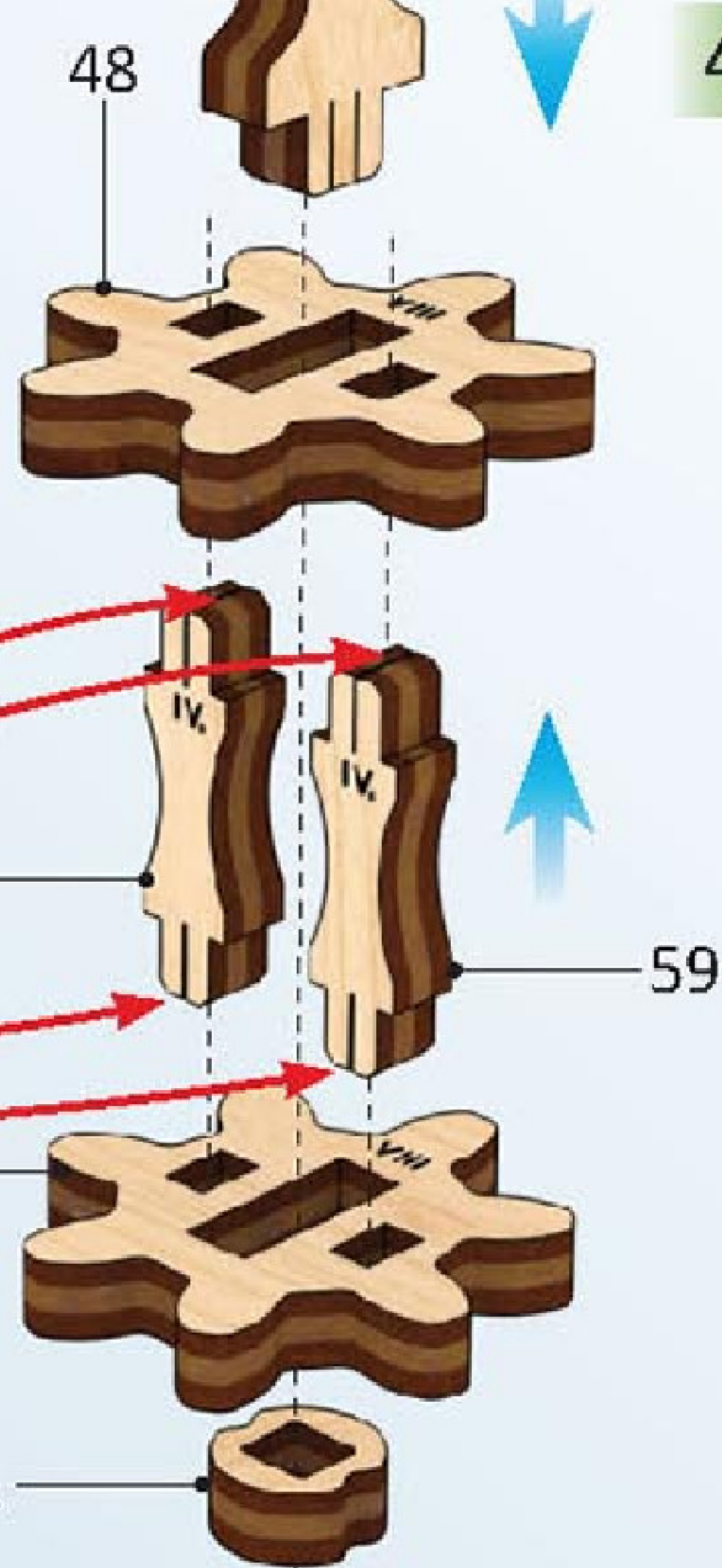

4

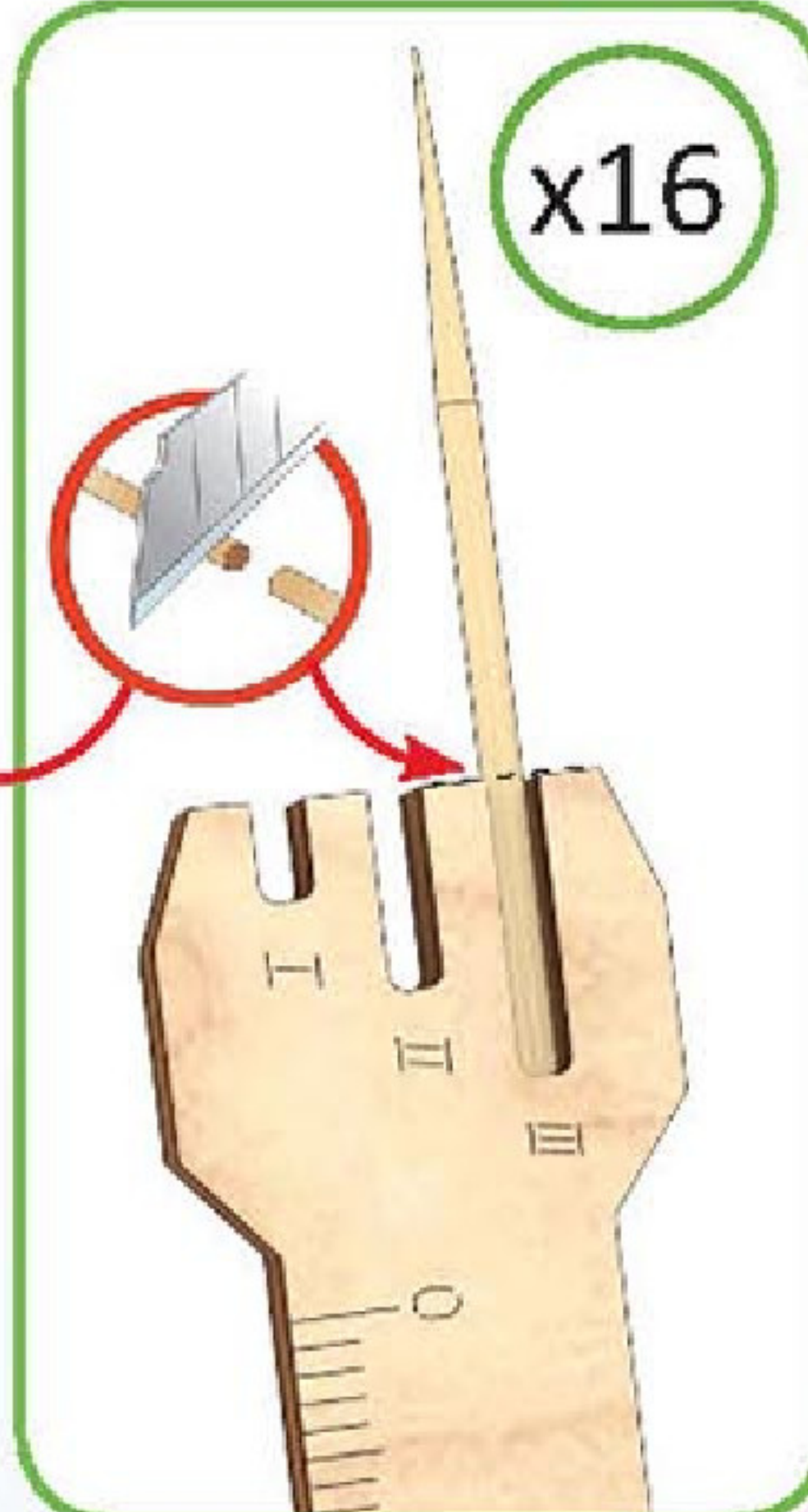

5

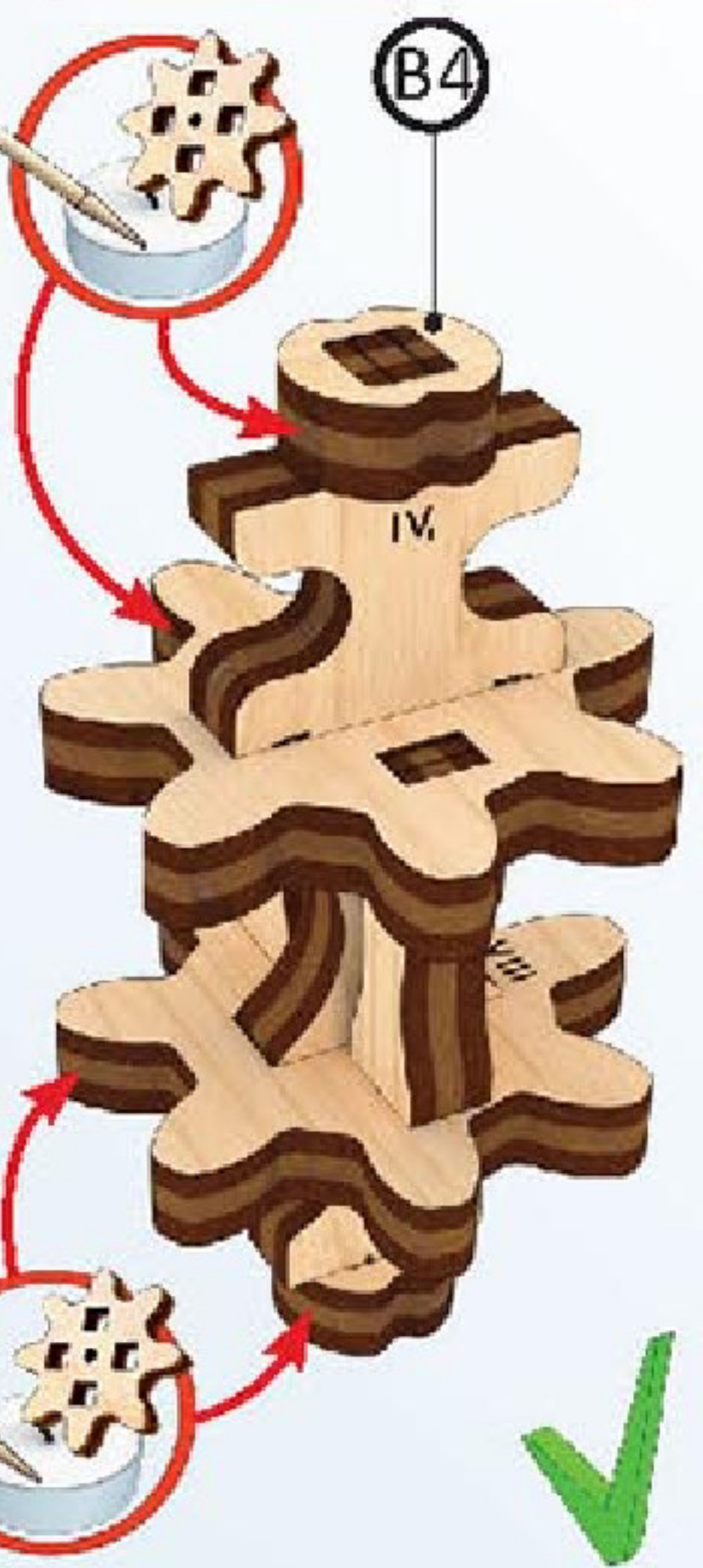

5

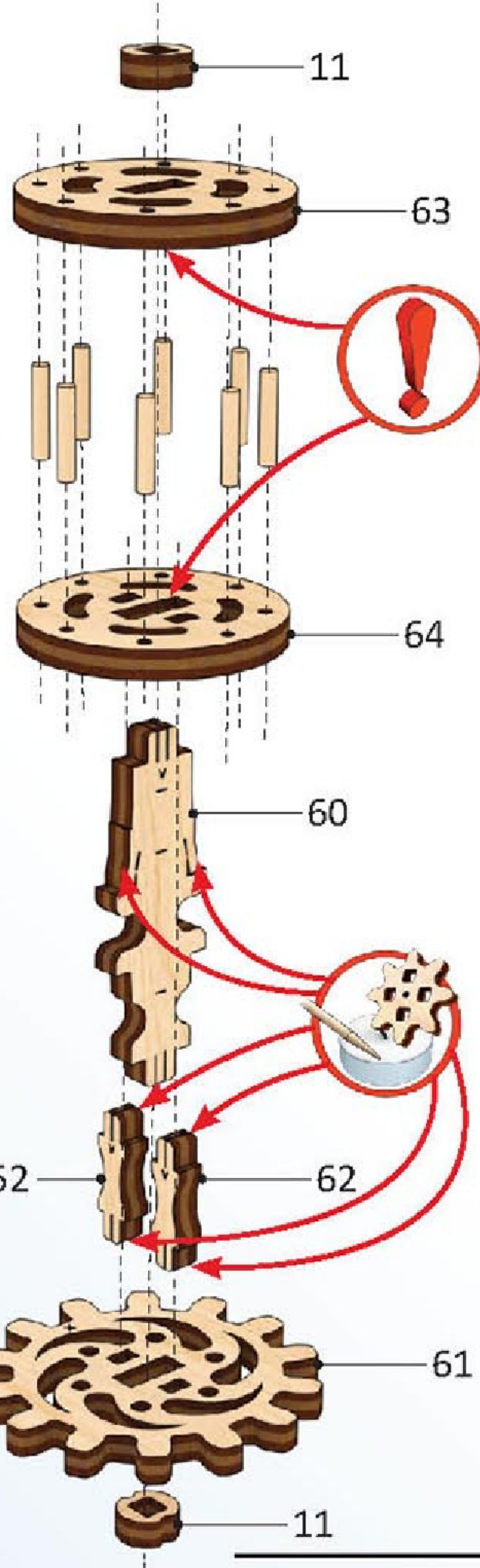

6

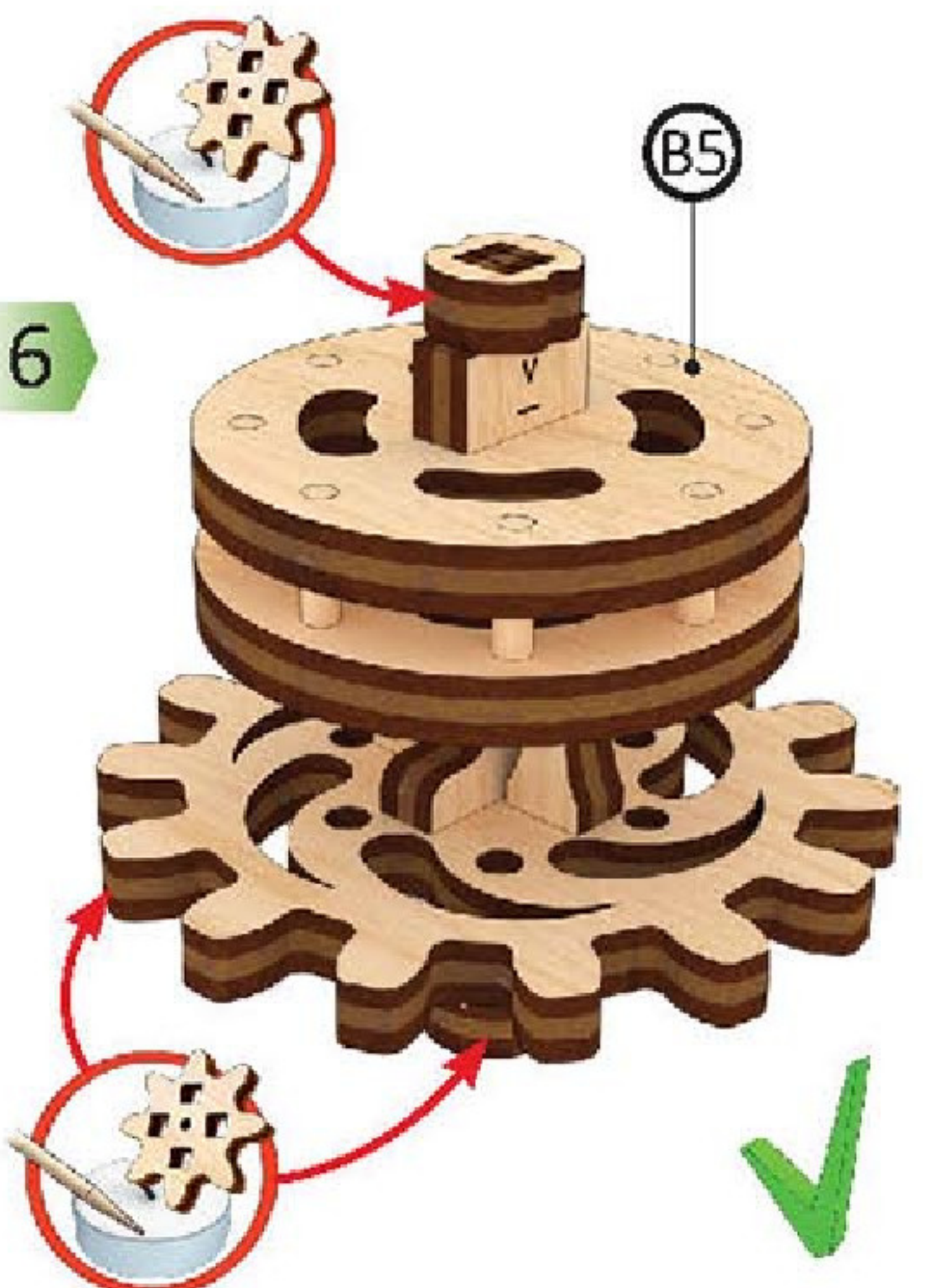

12

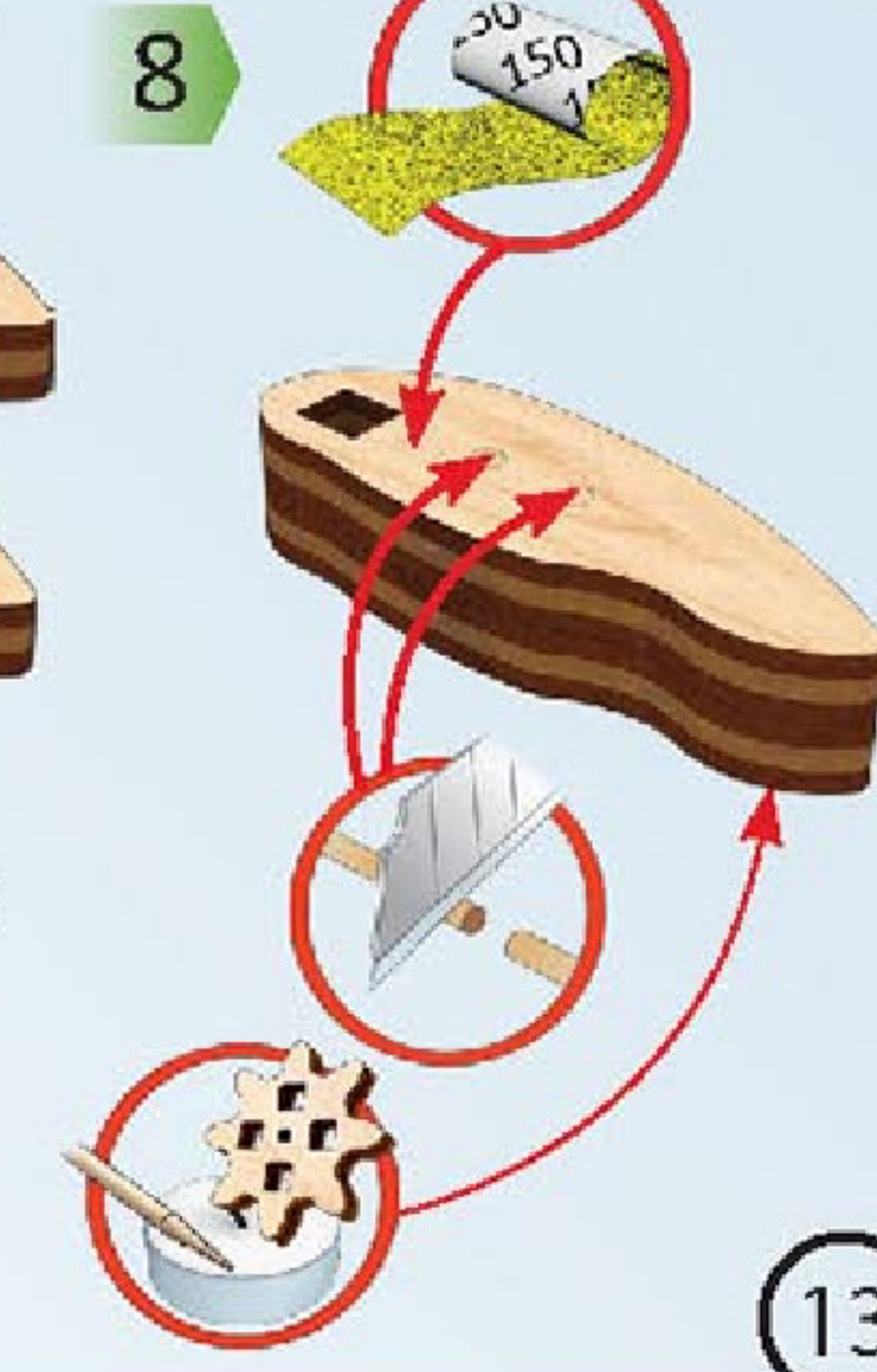
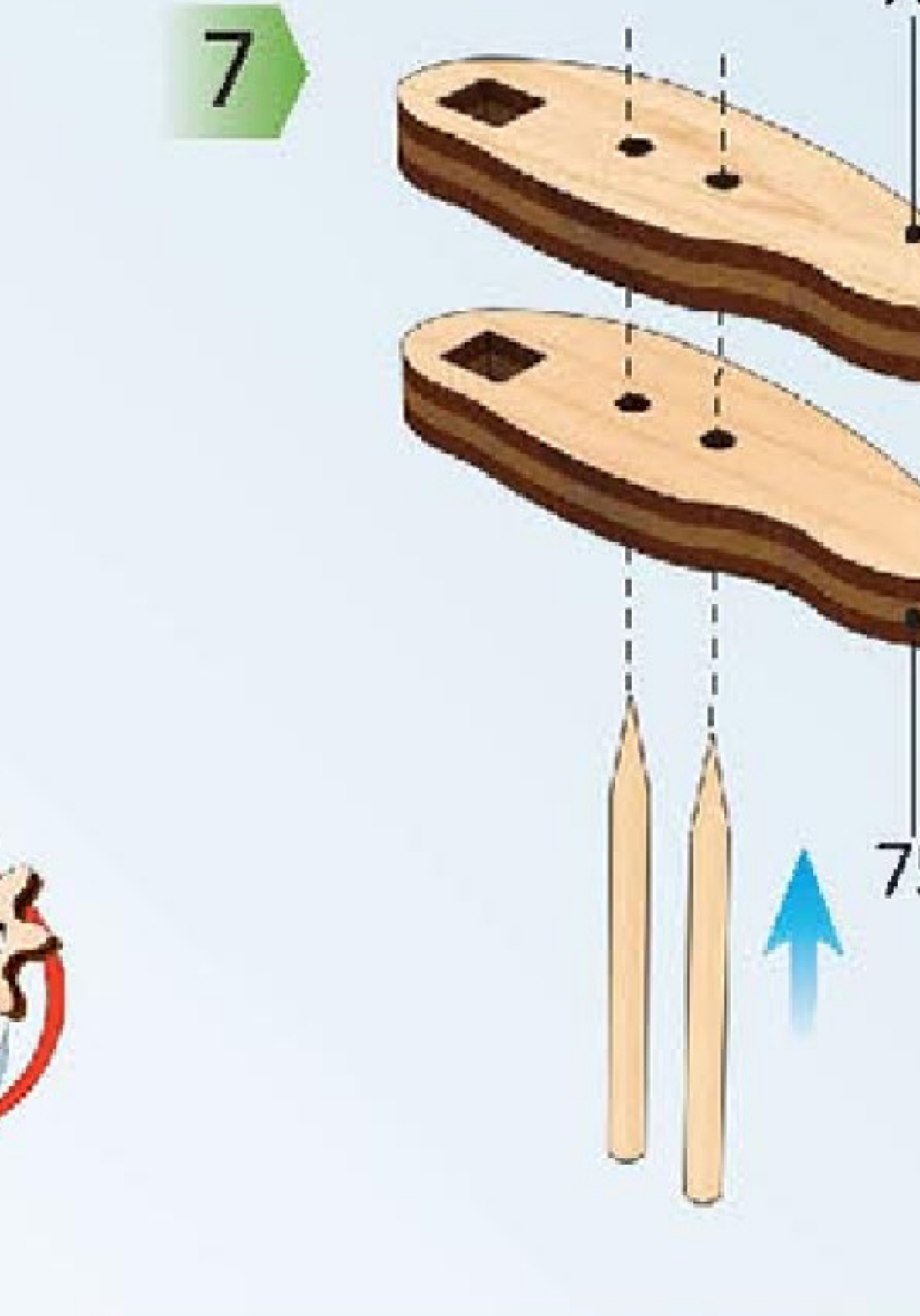
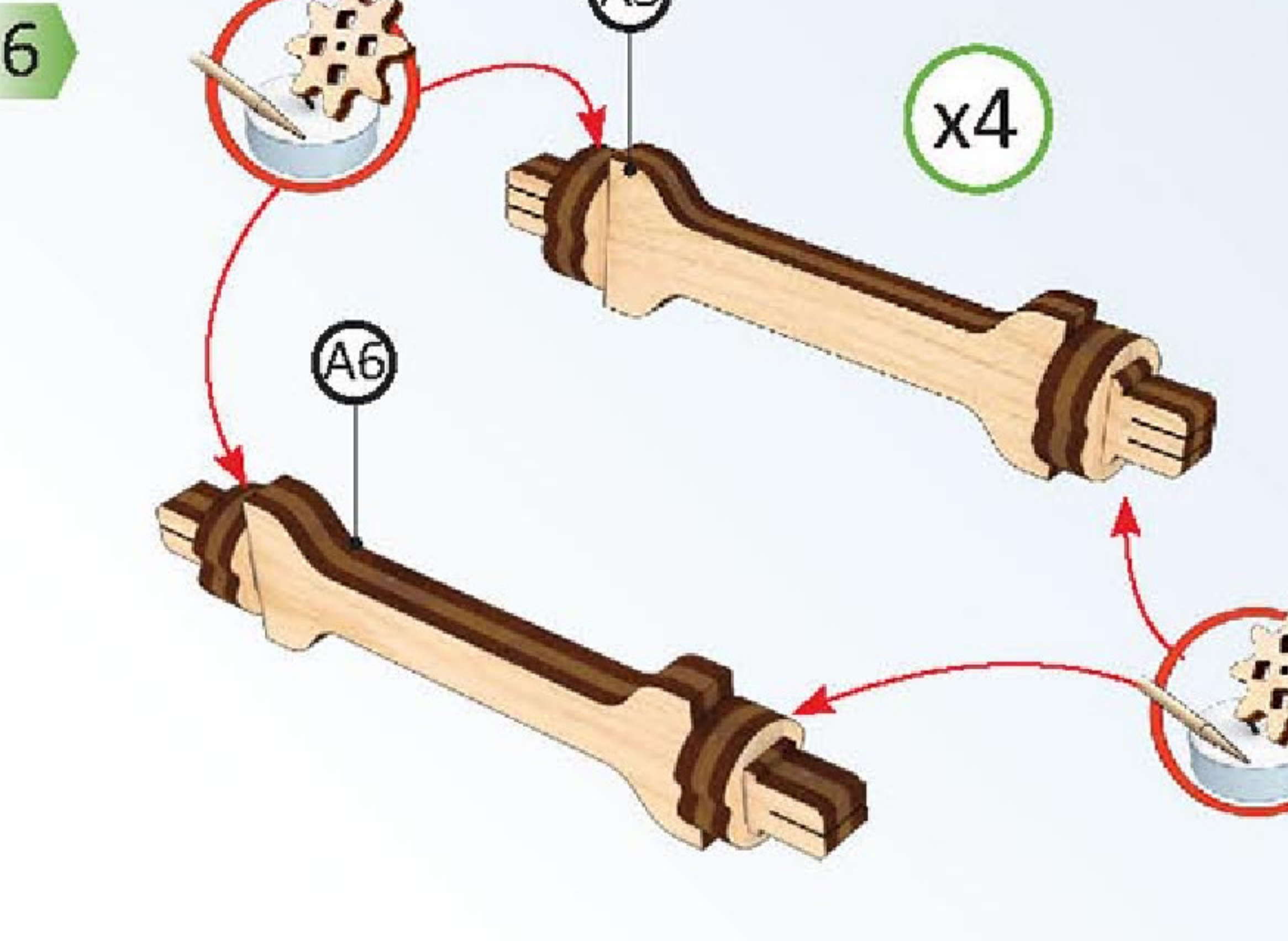
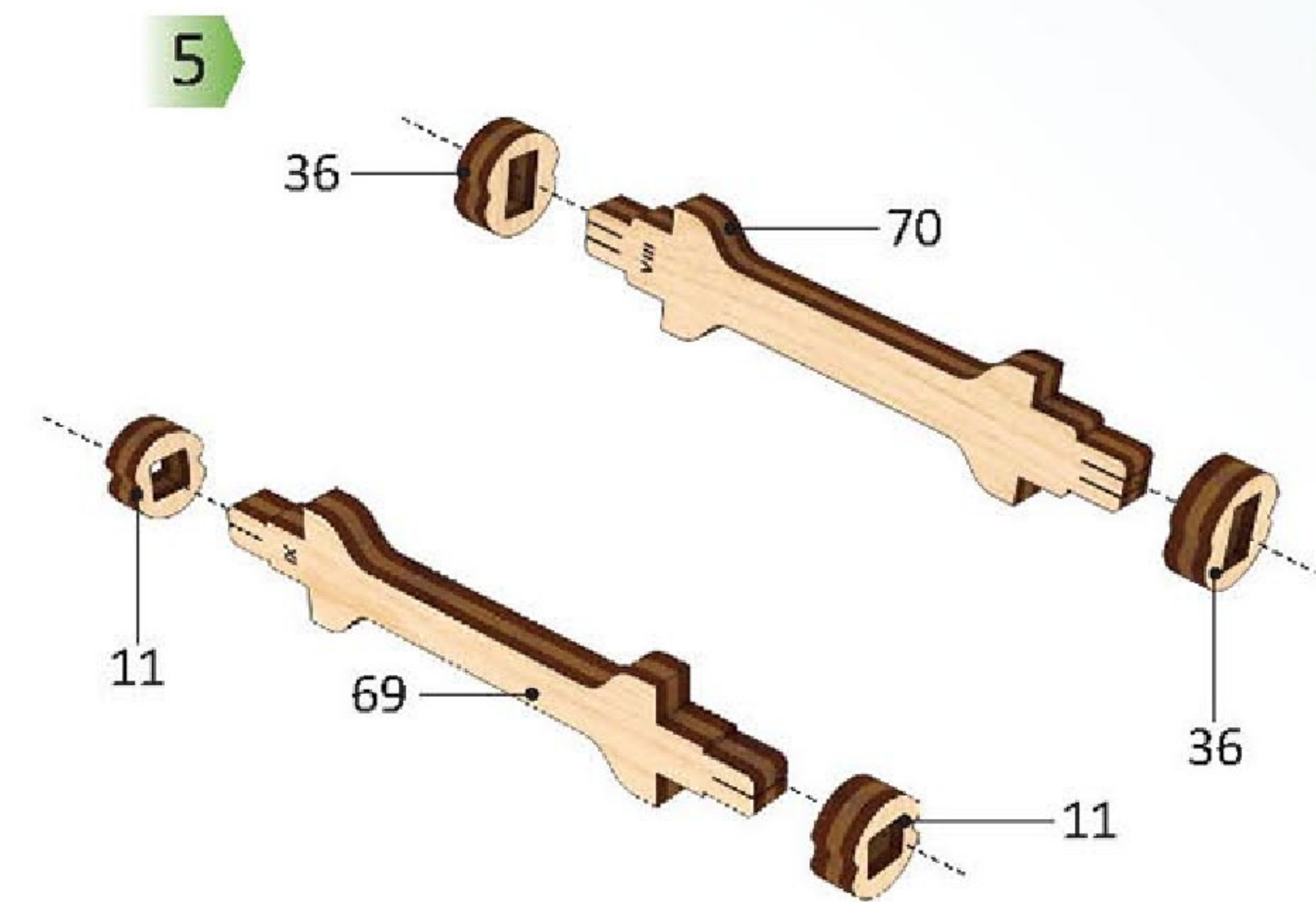
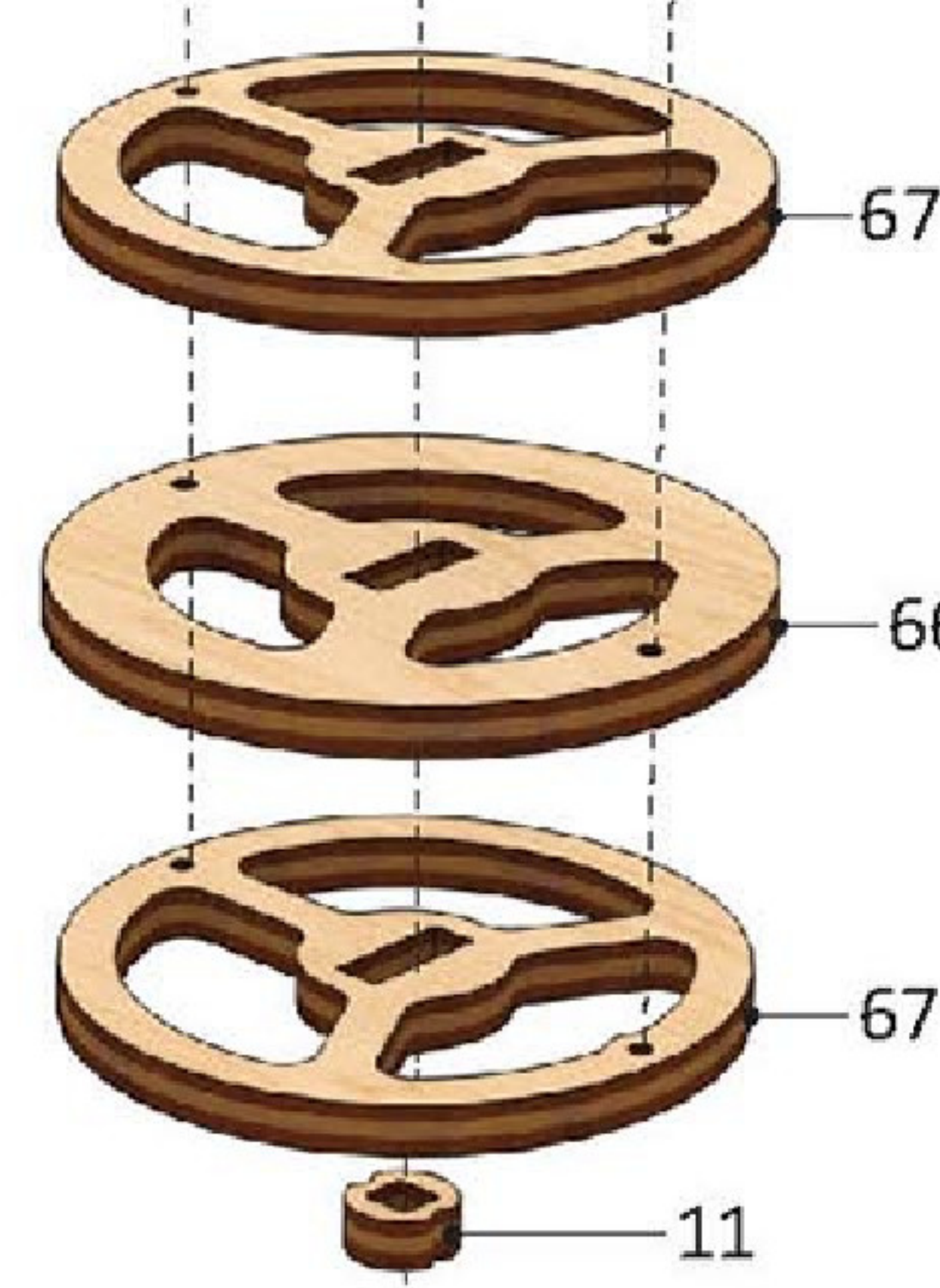
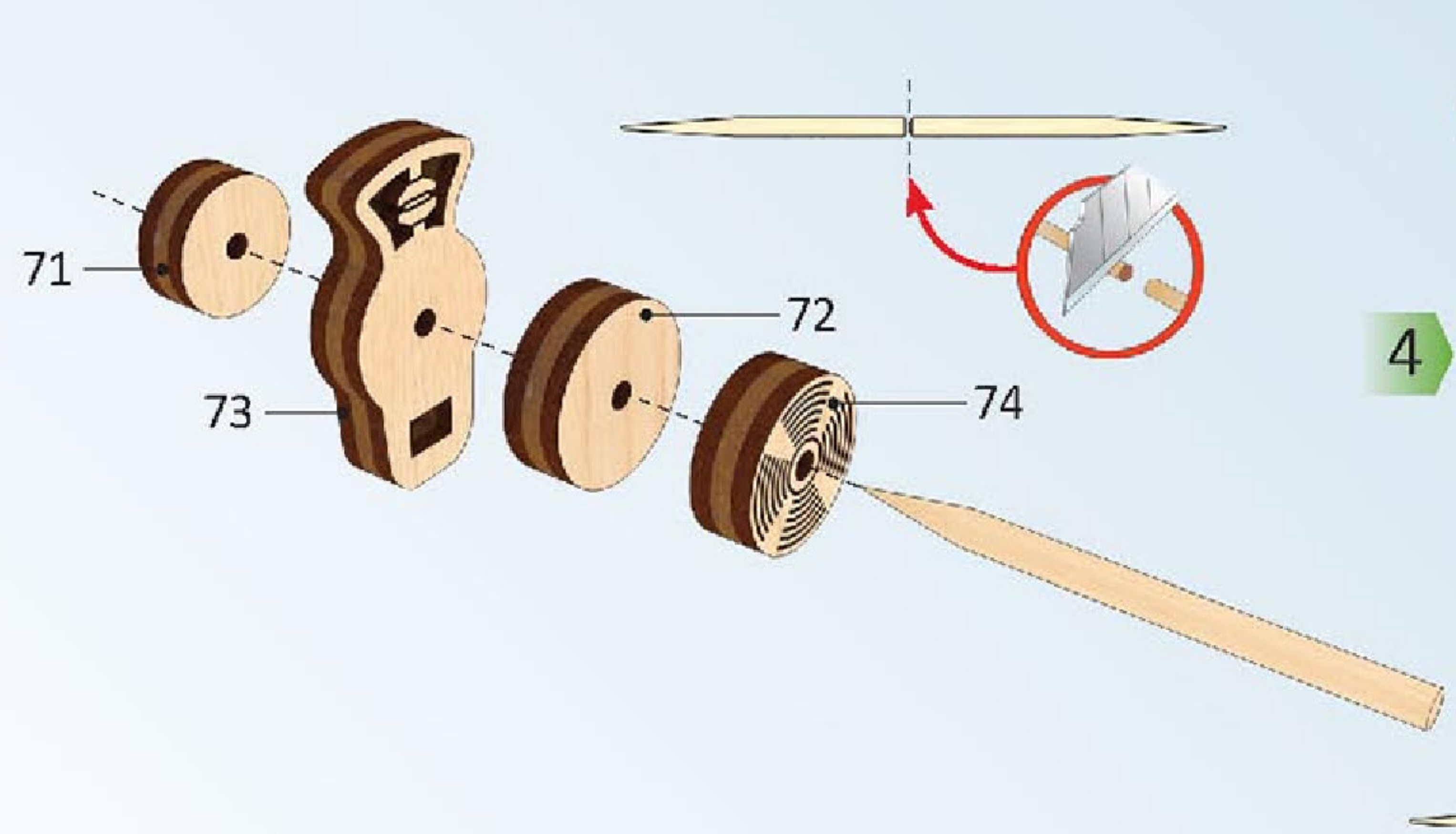
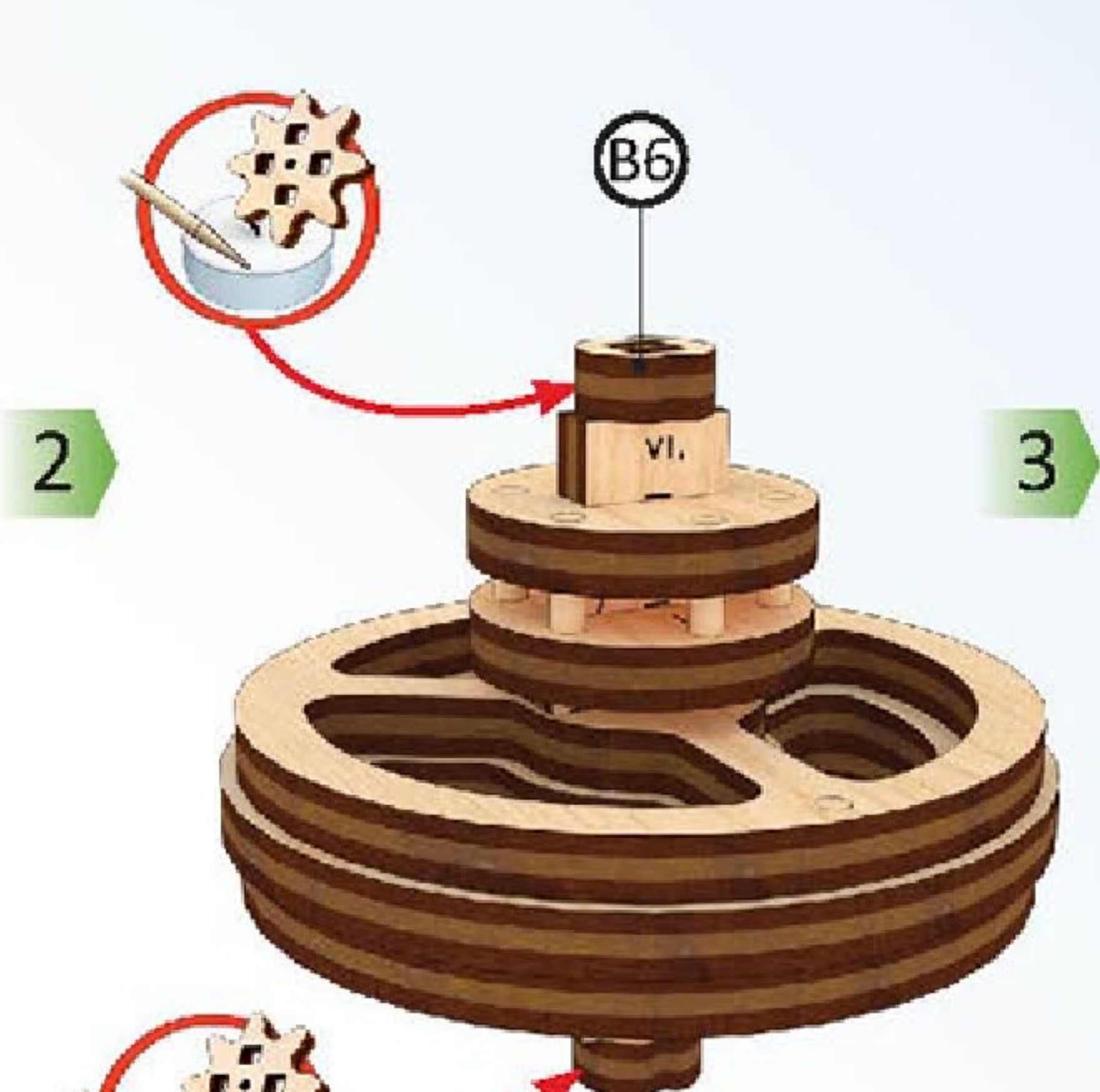
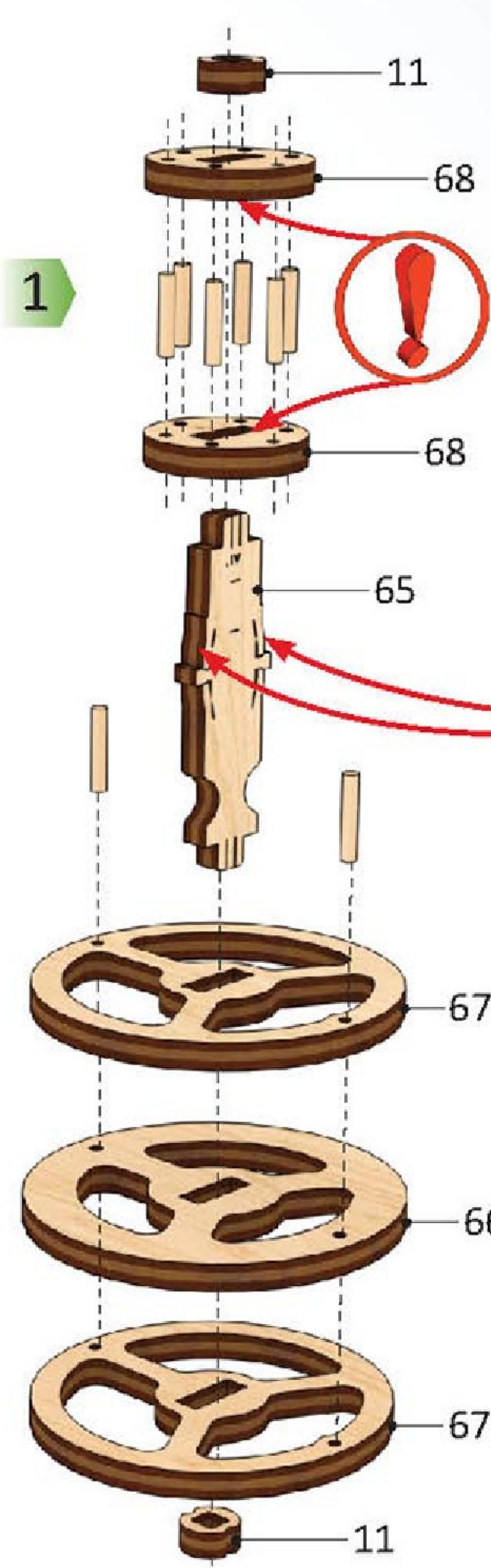
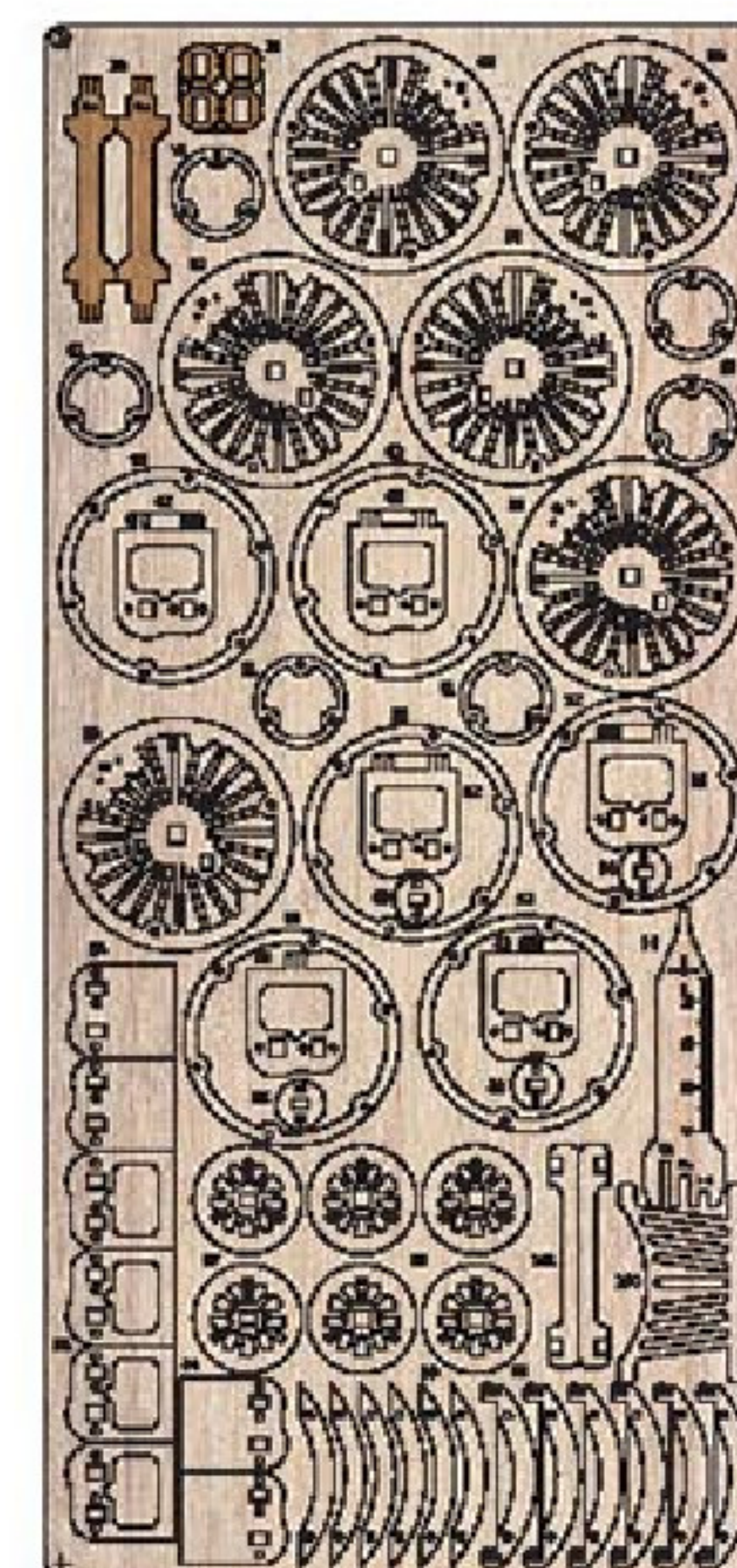
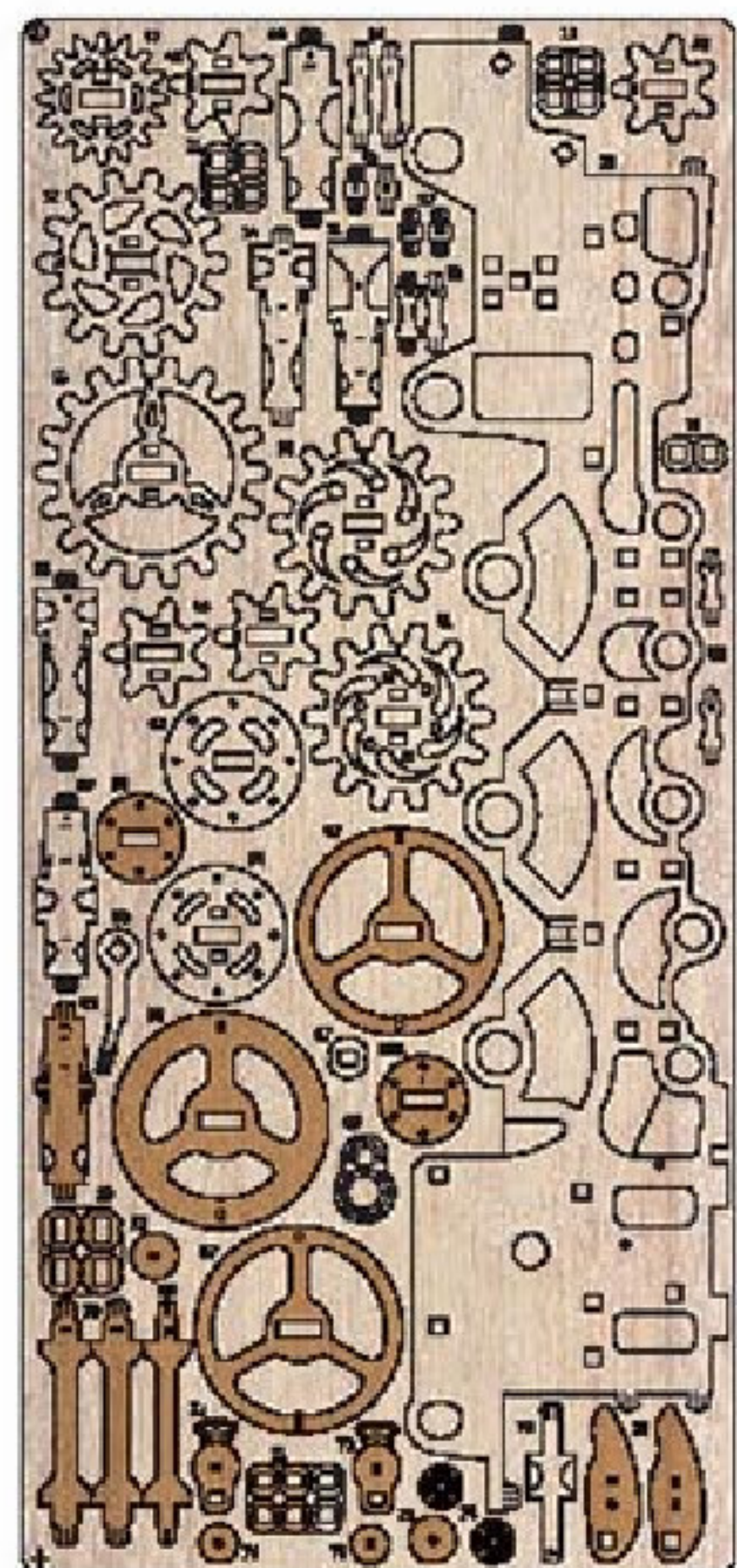

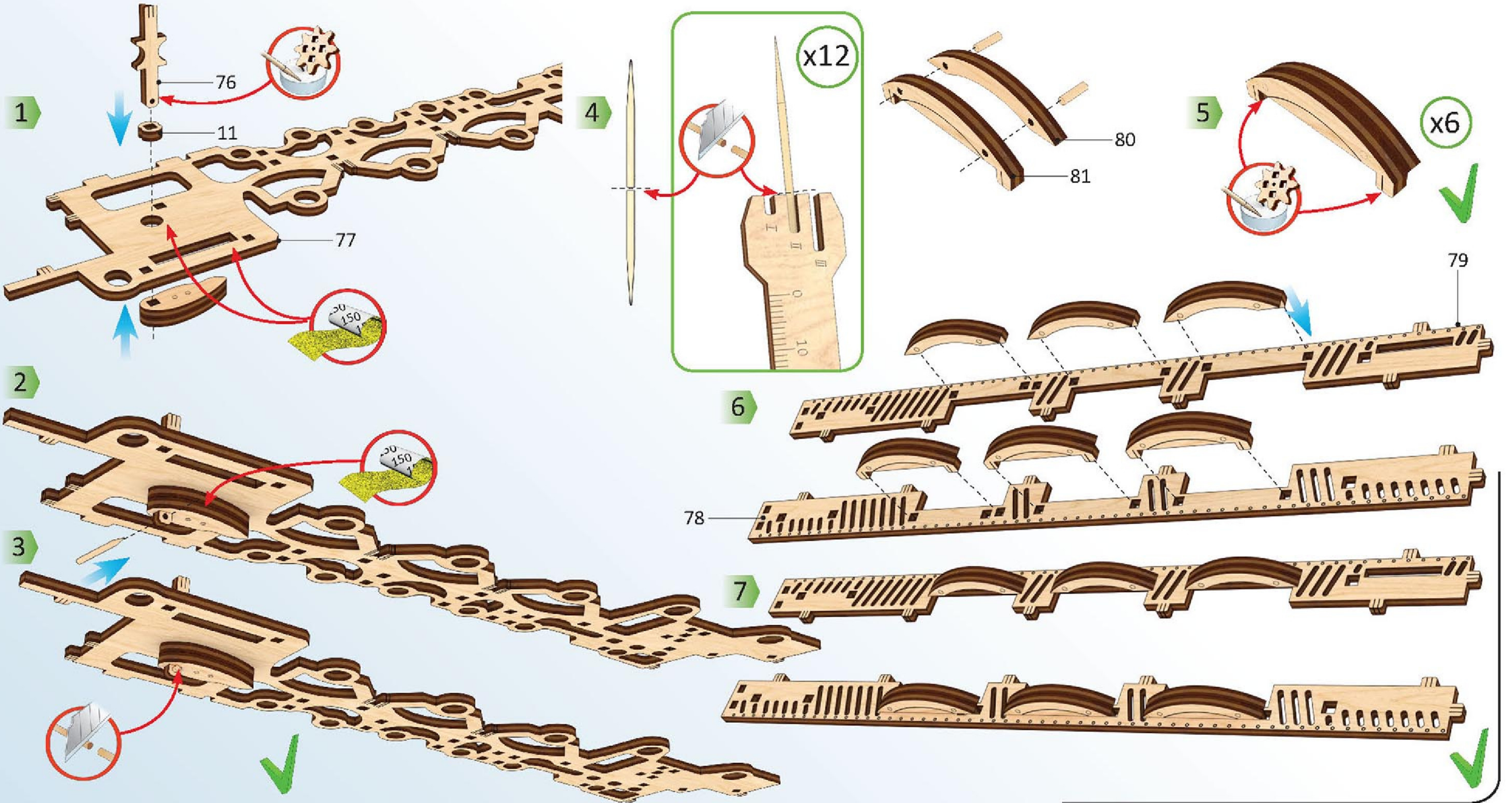
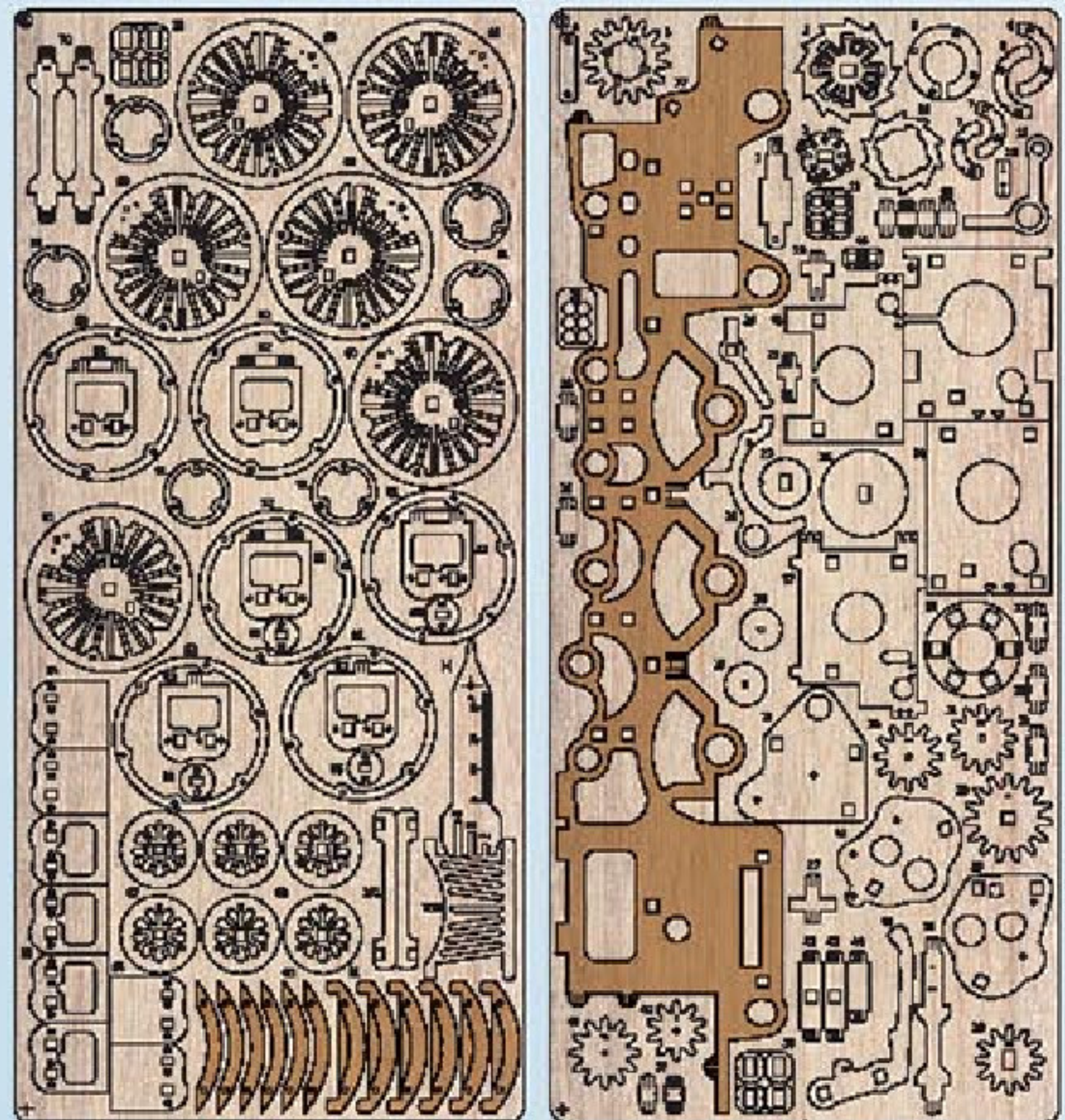
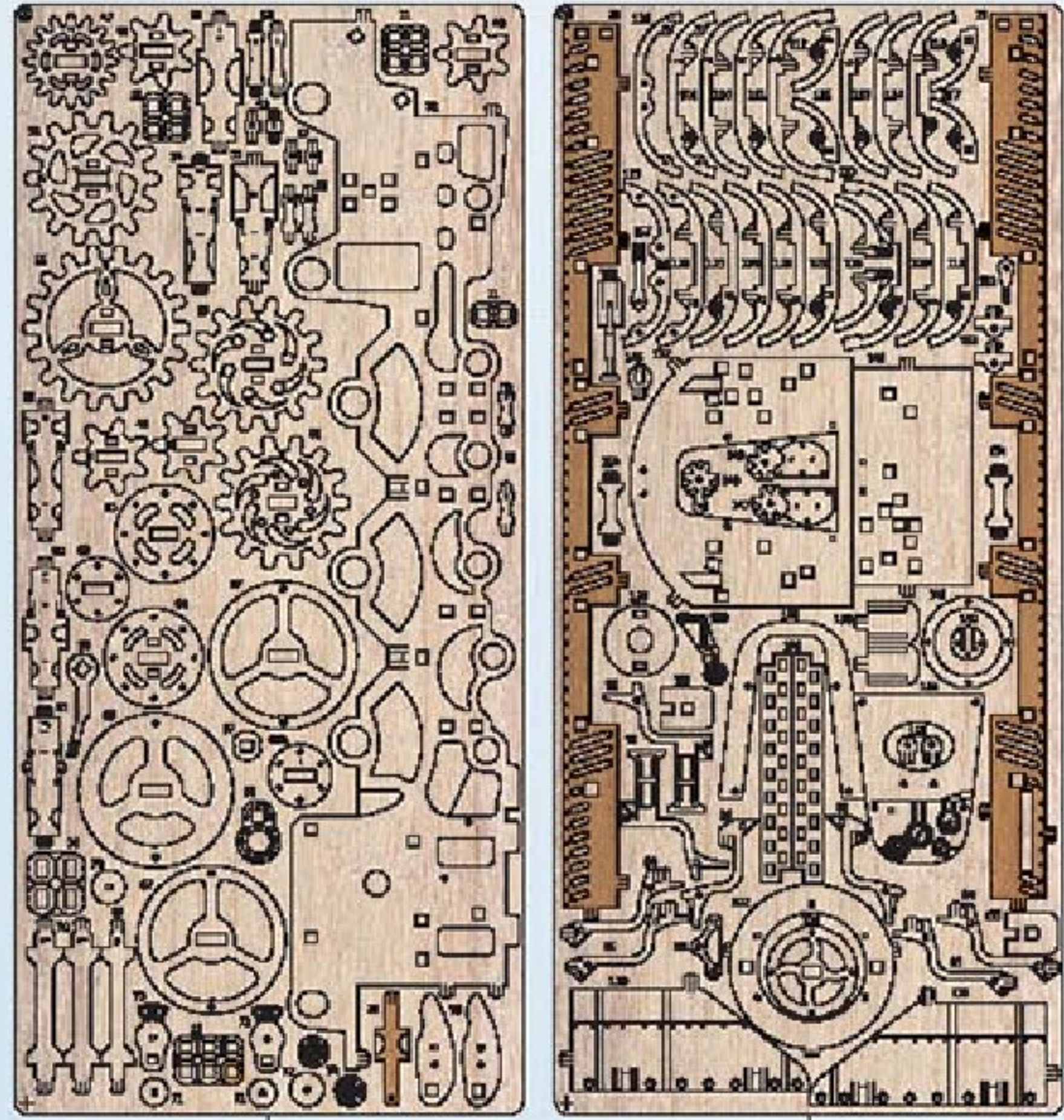

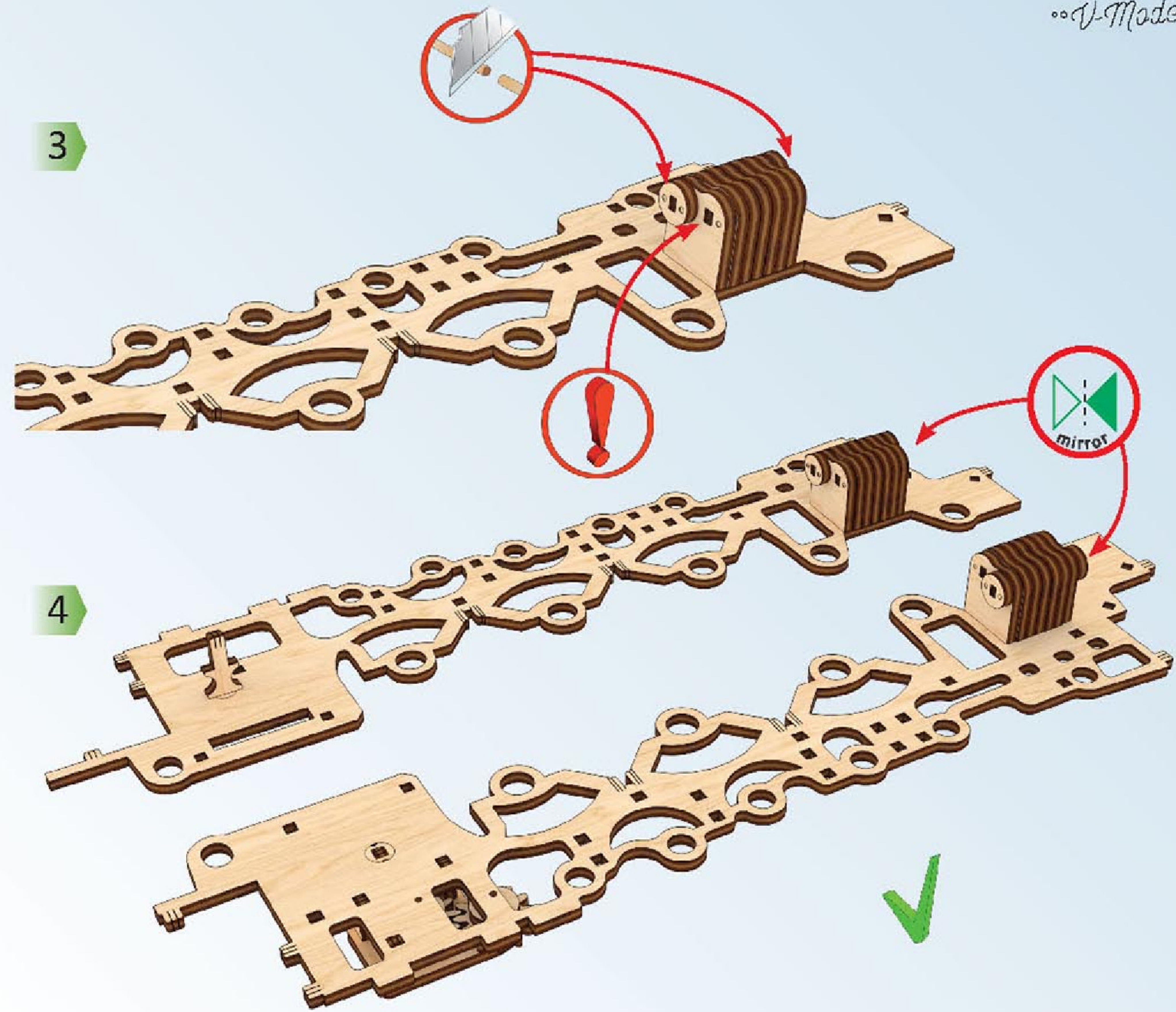
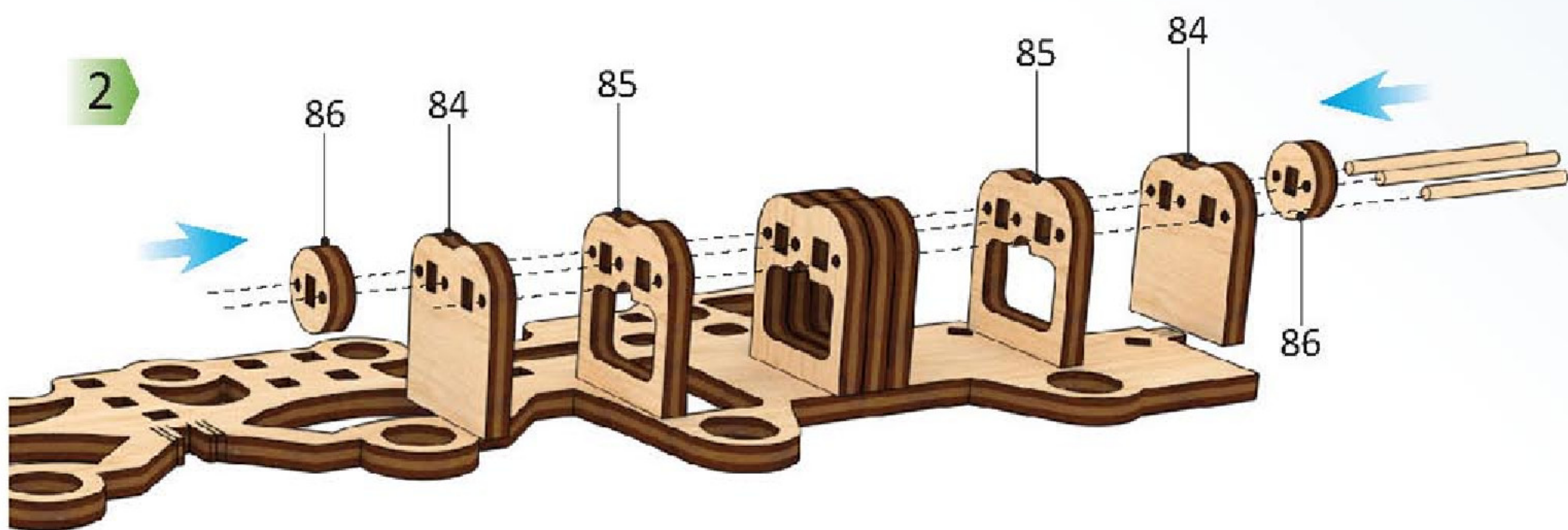
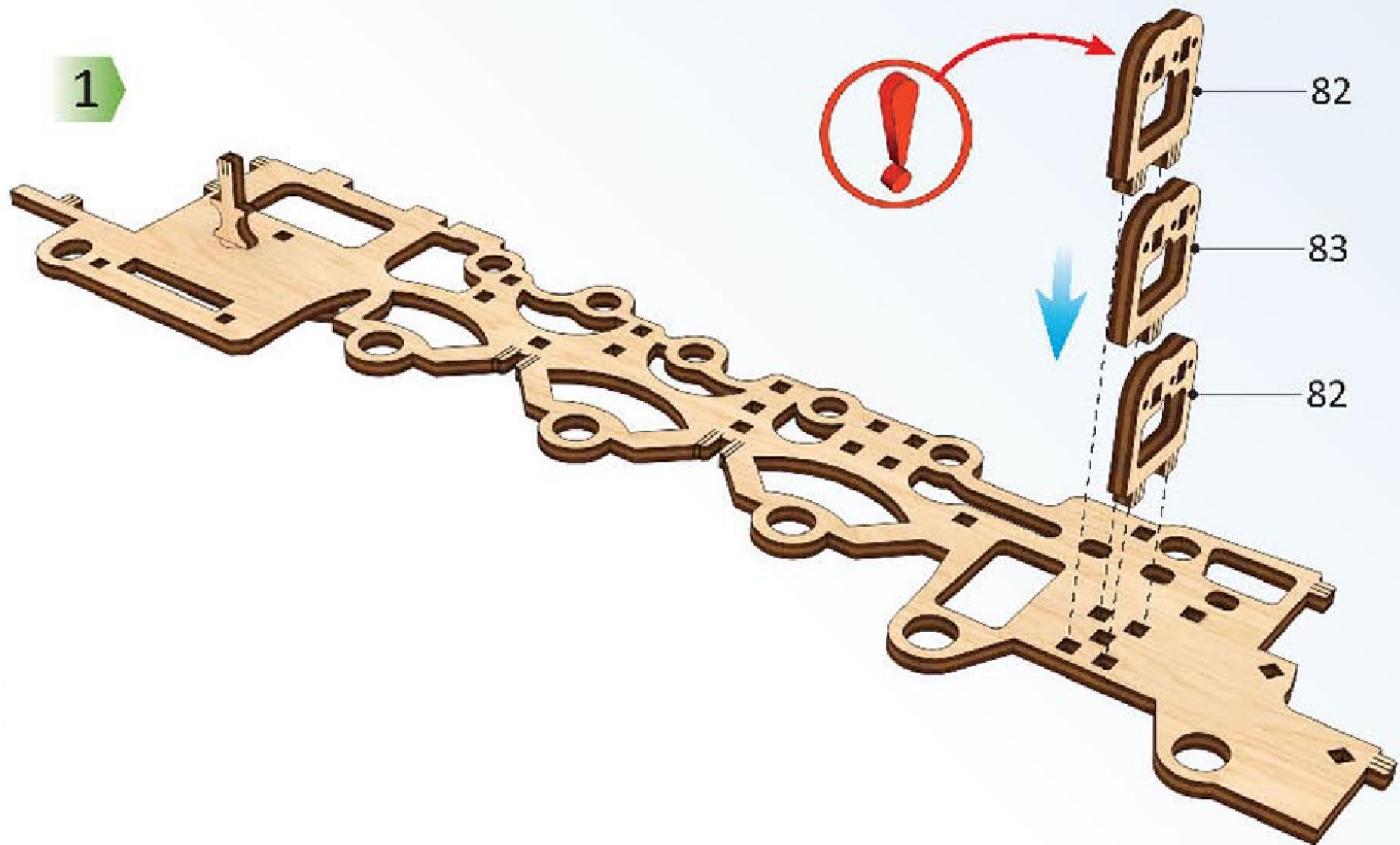
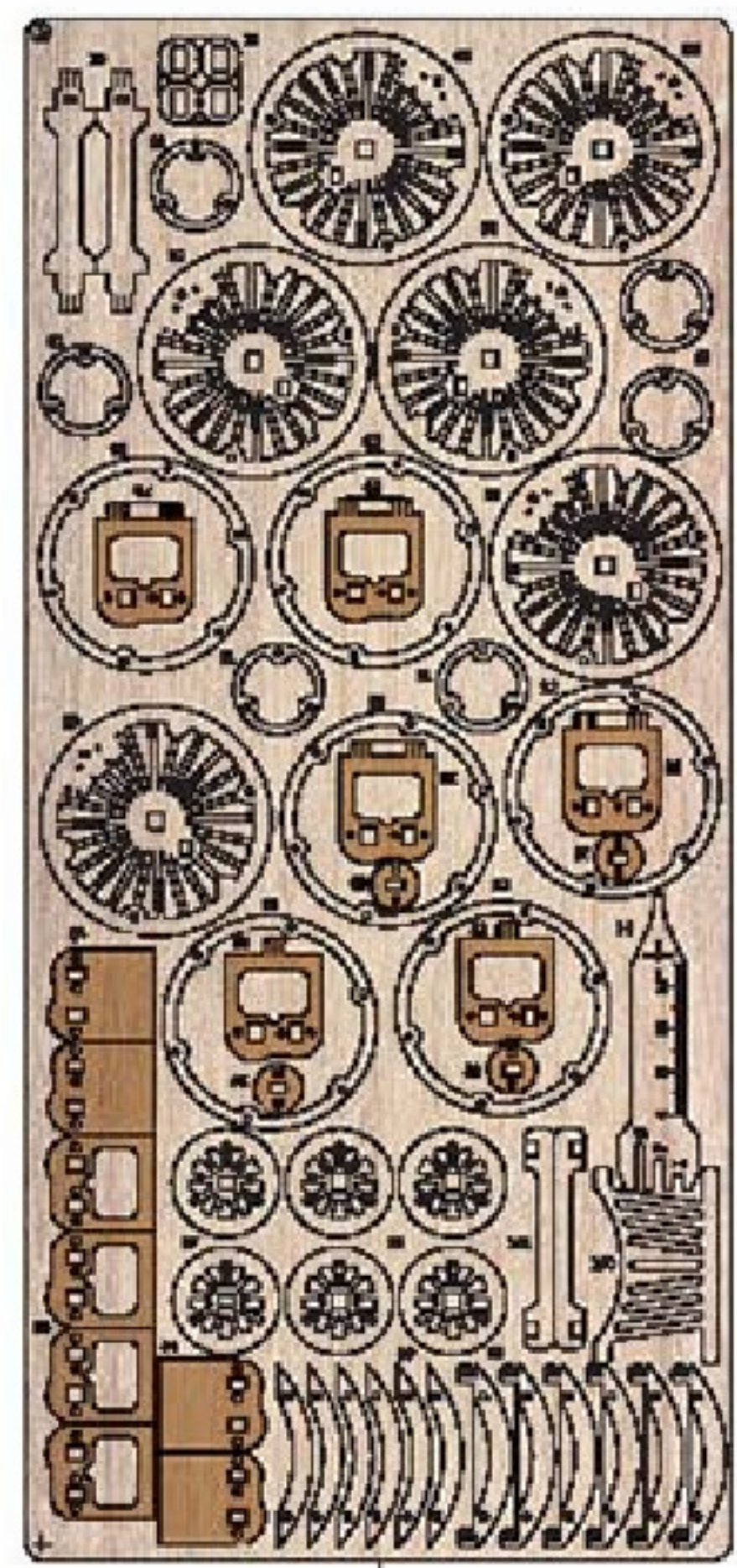

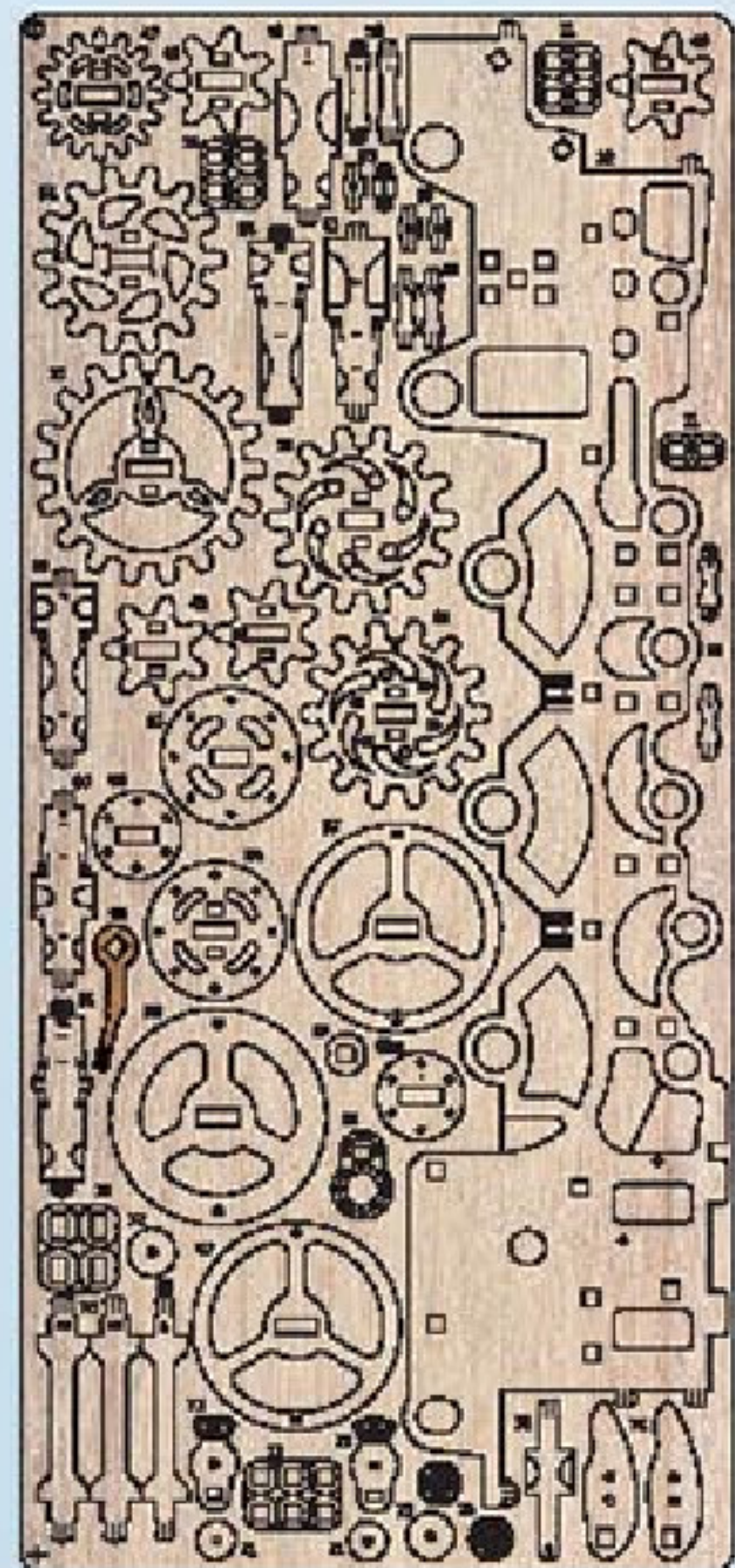
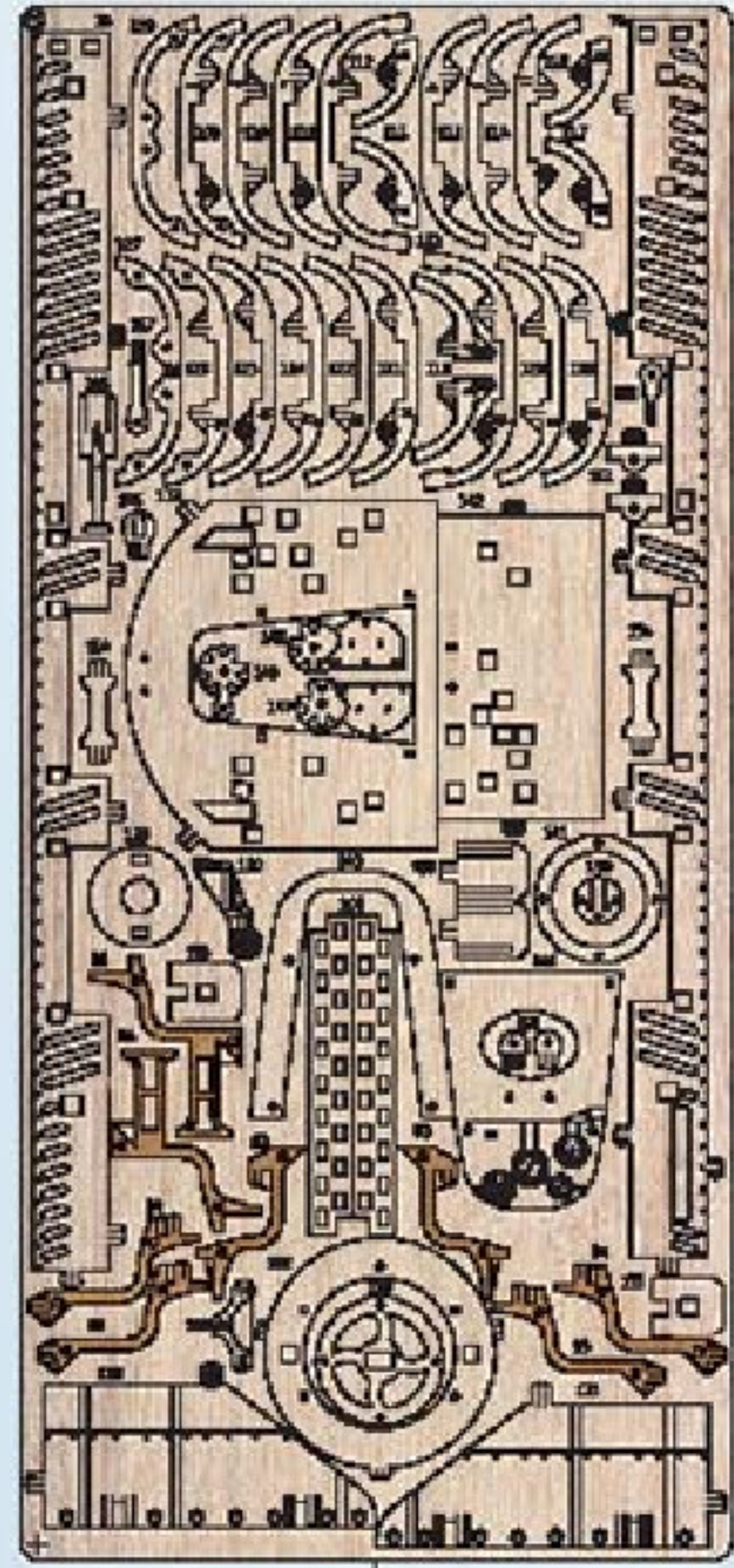

16

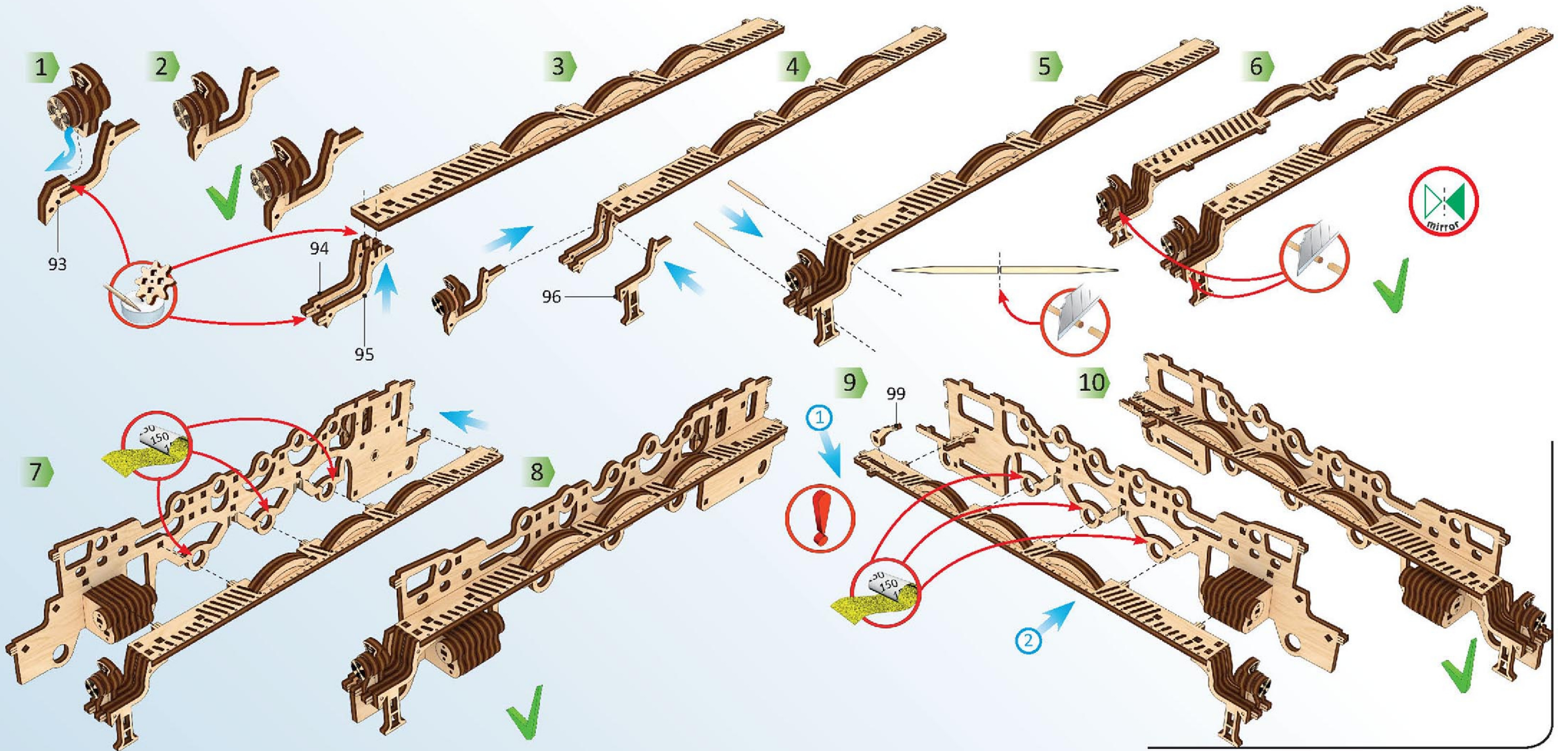



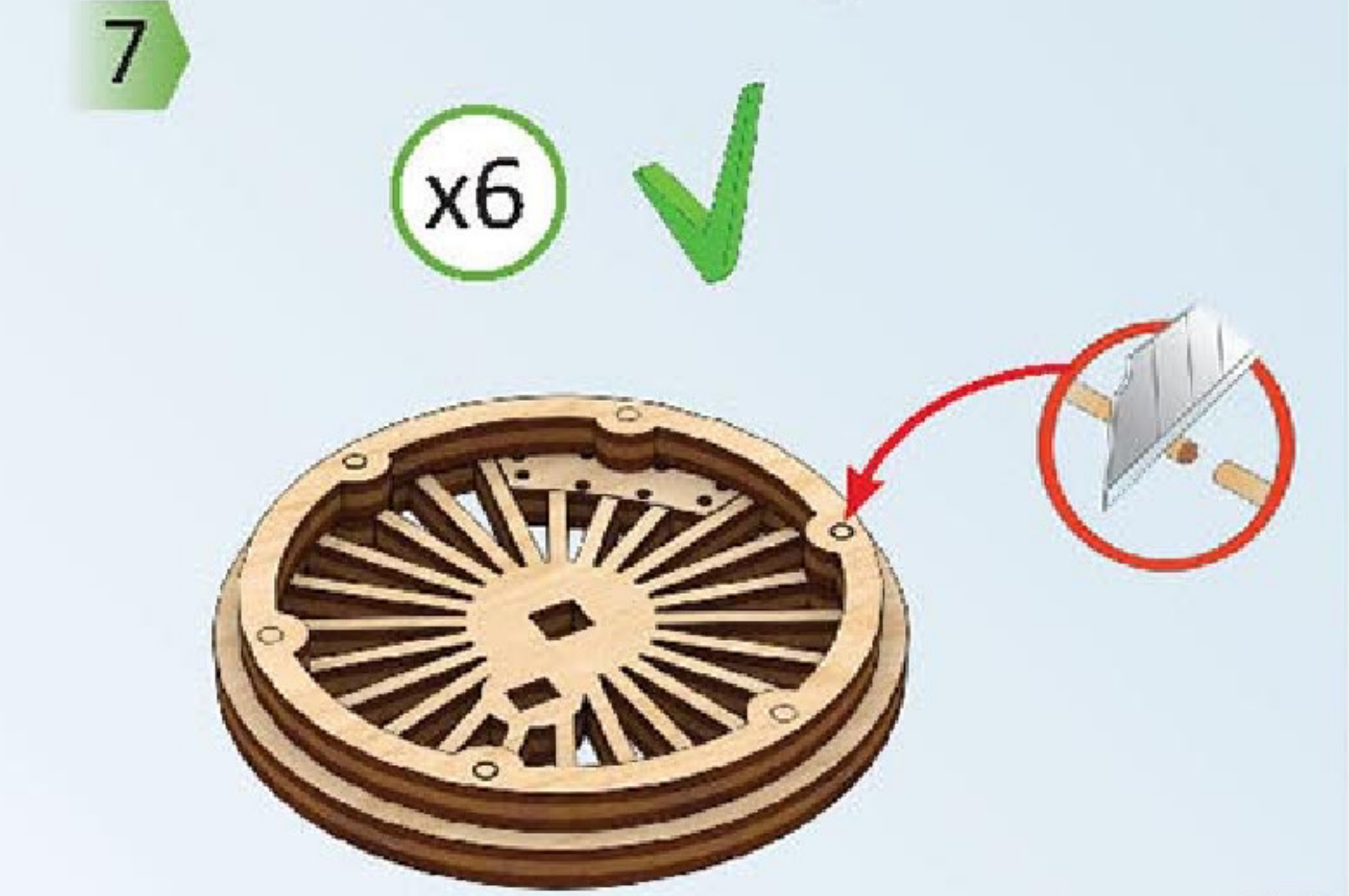
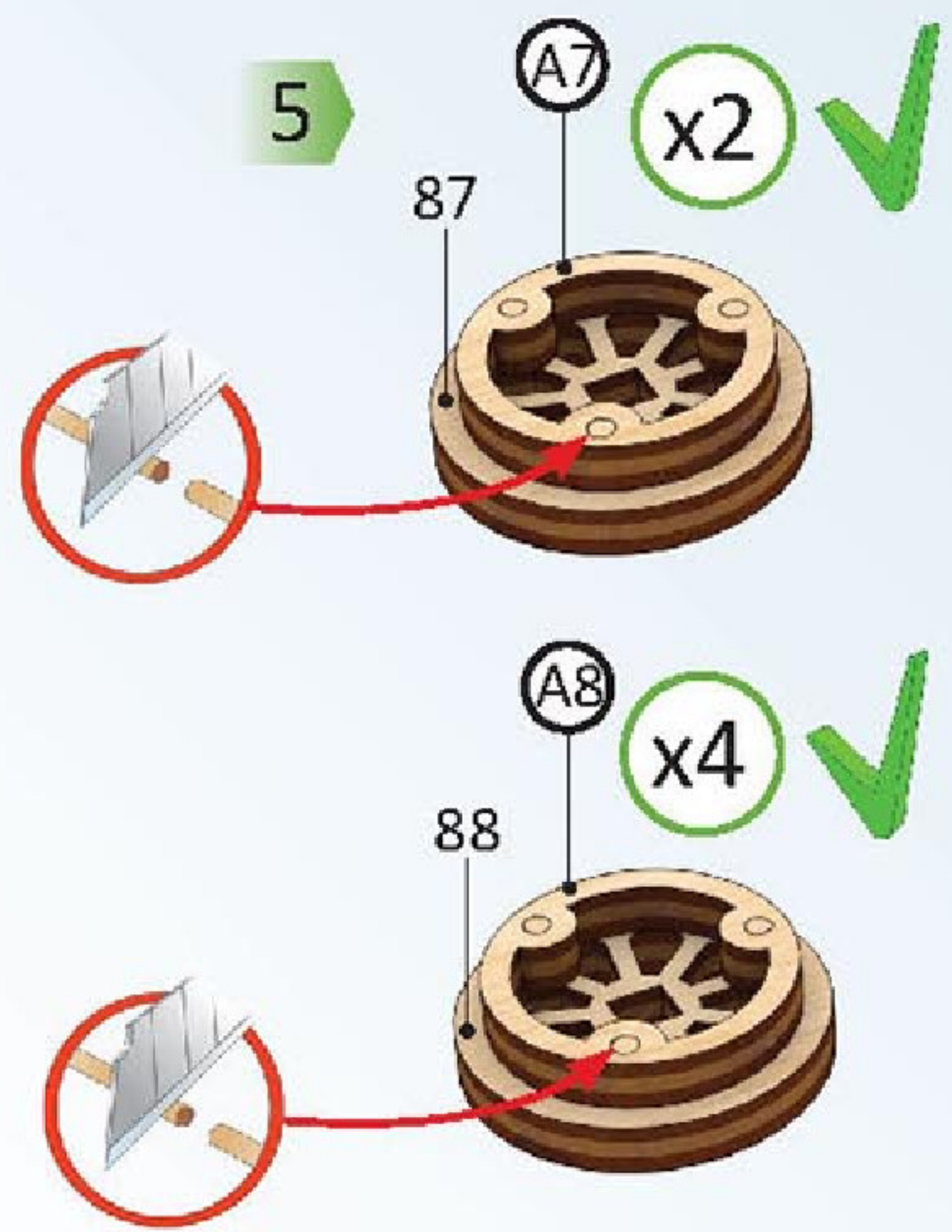
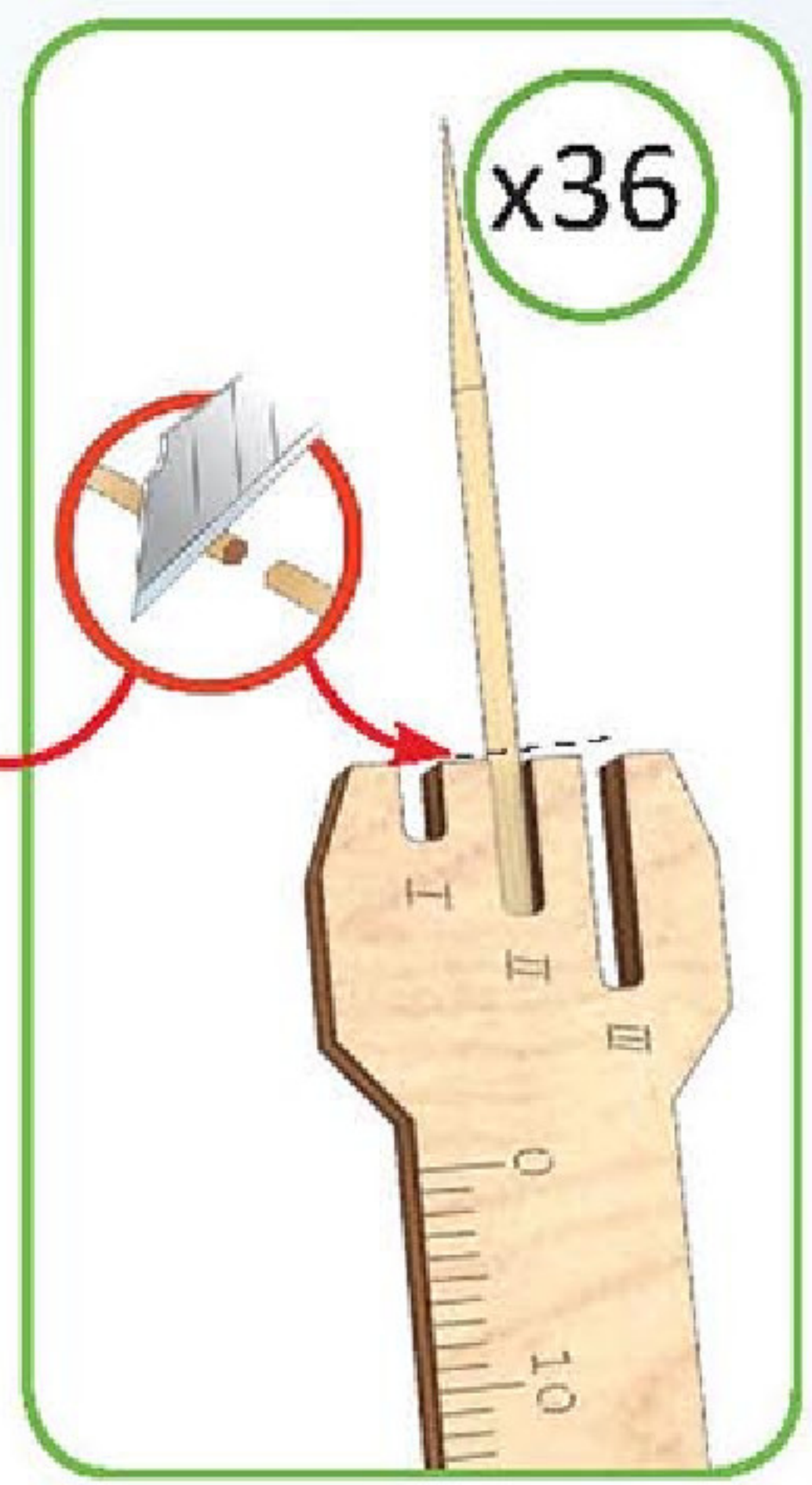
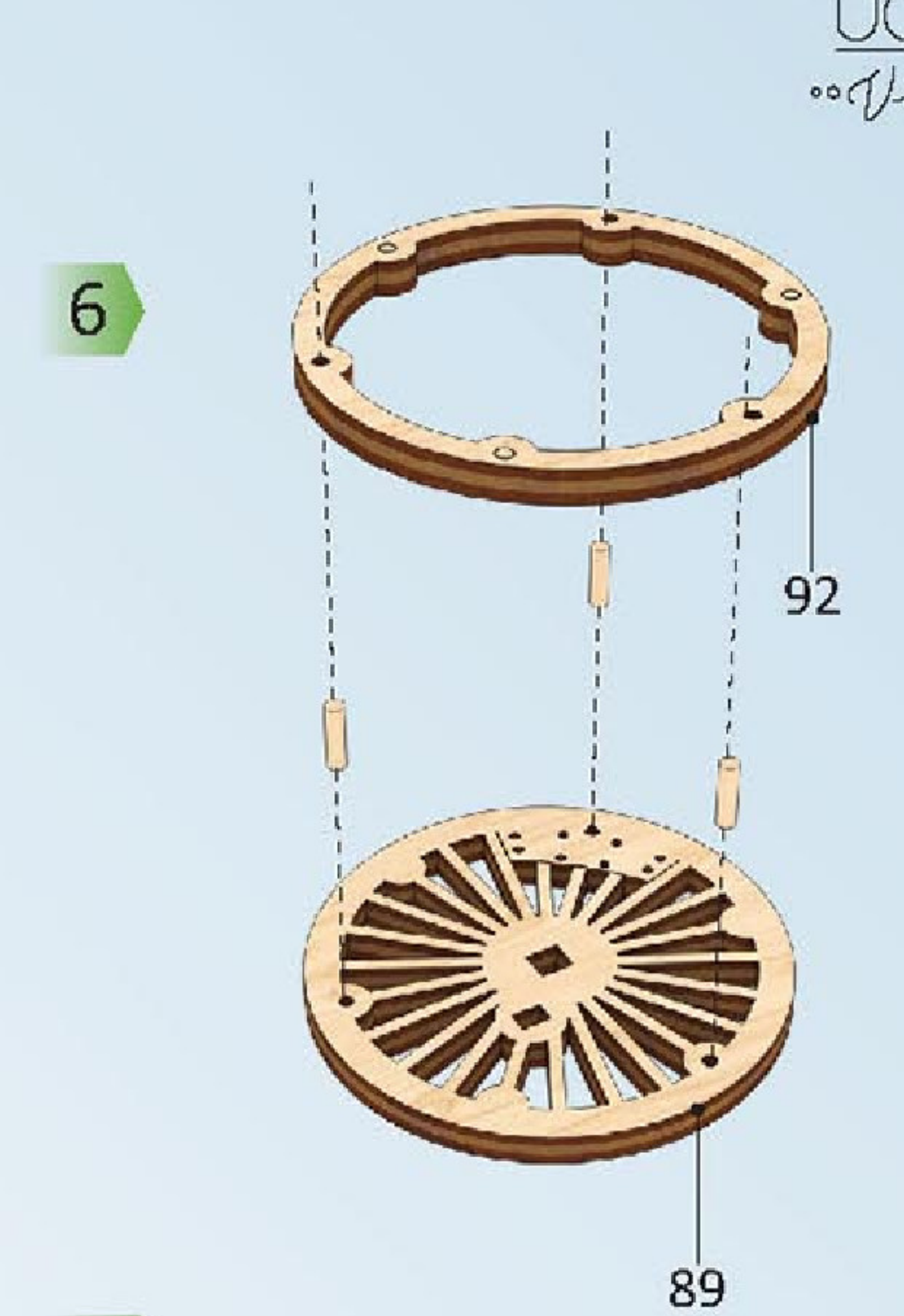
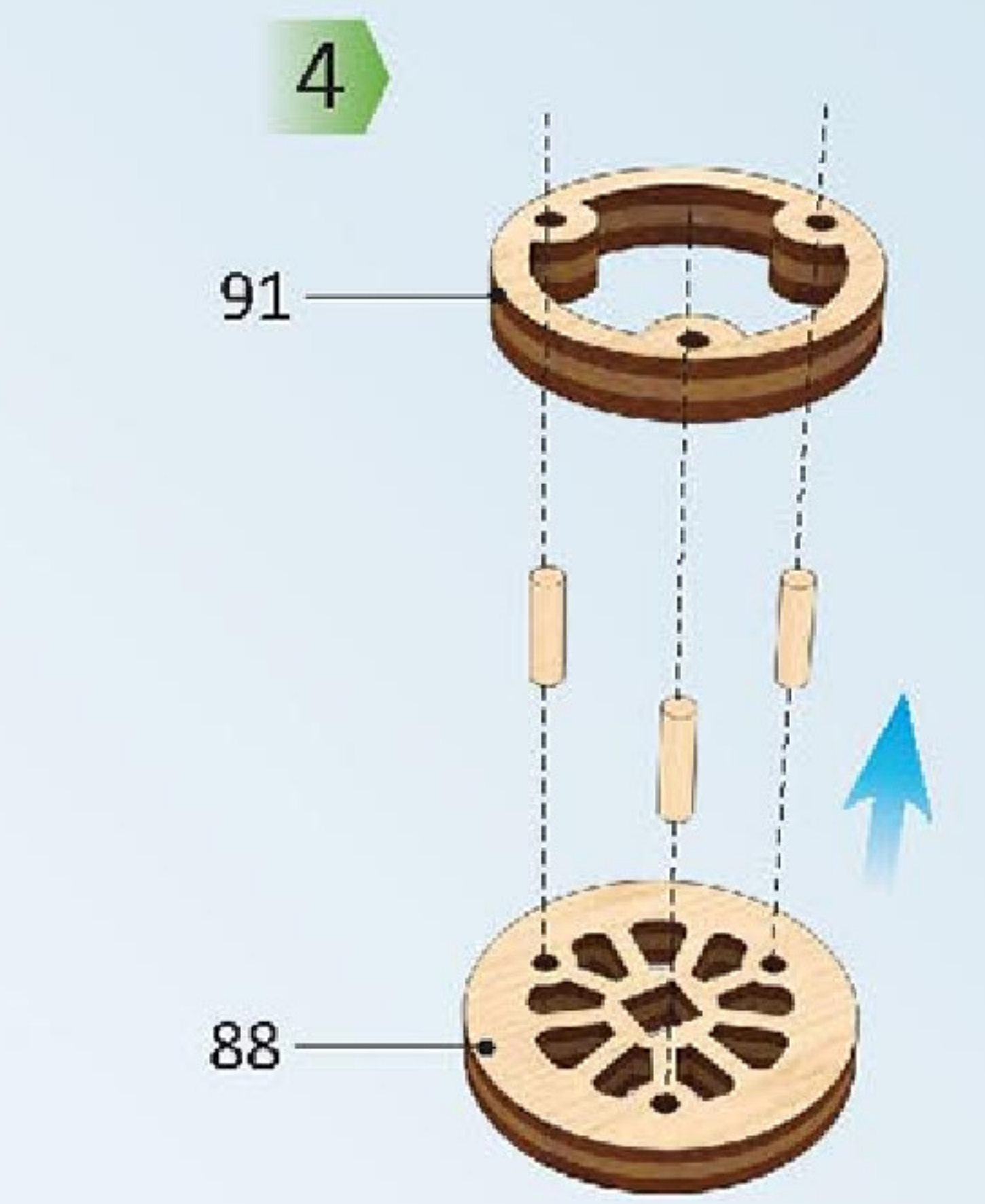
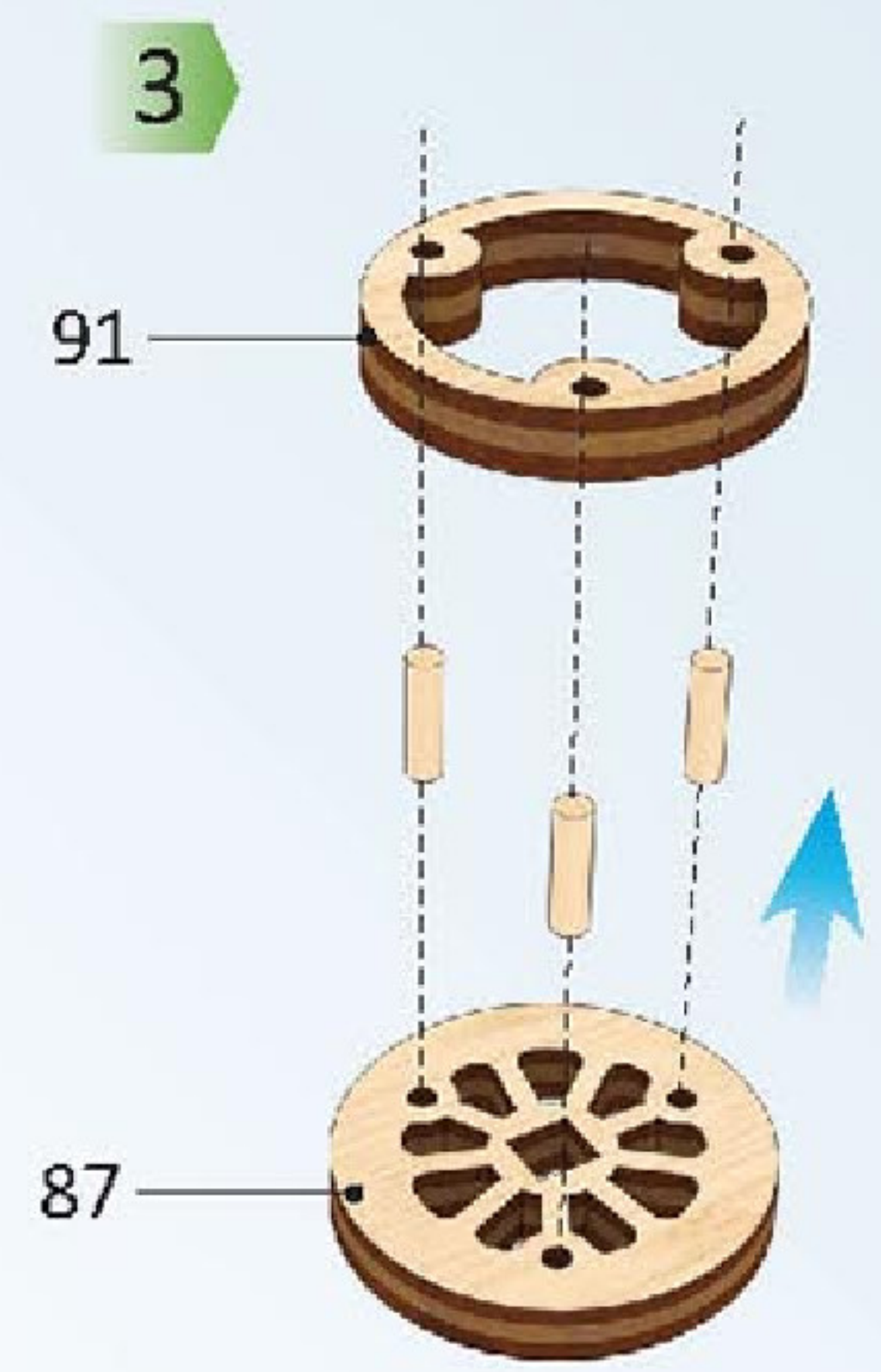
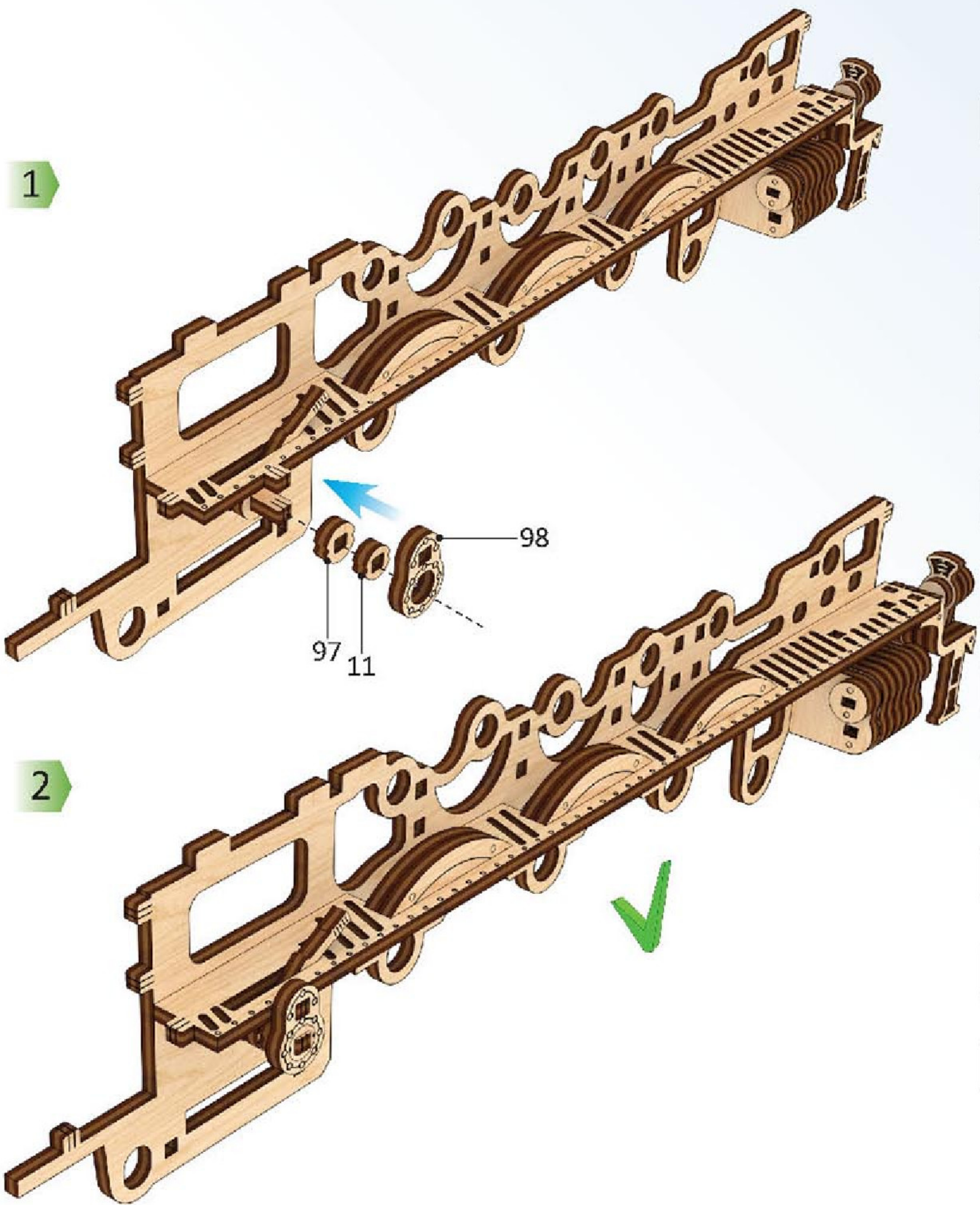
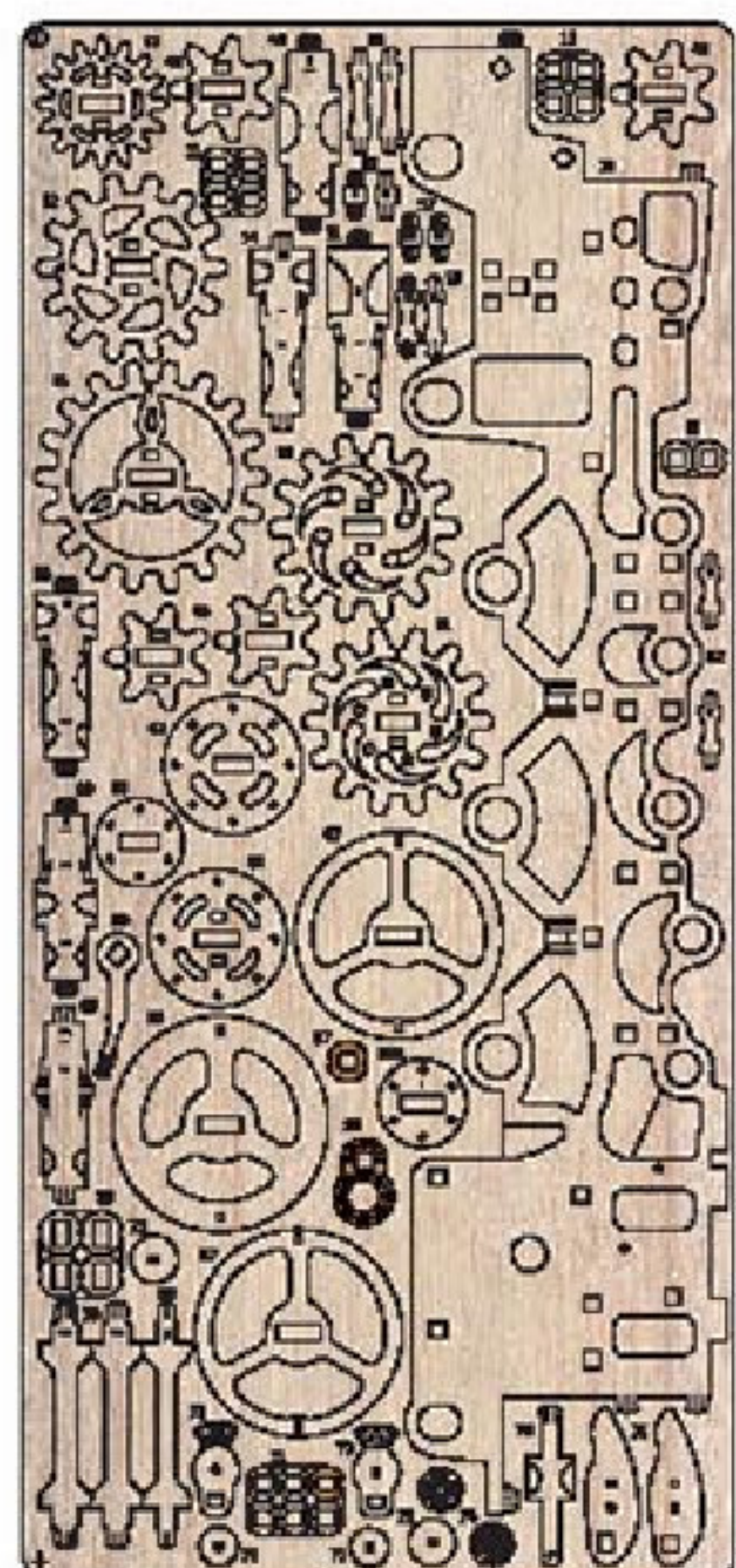
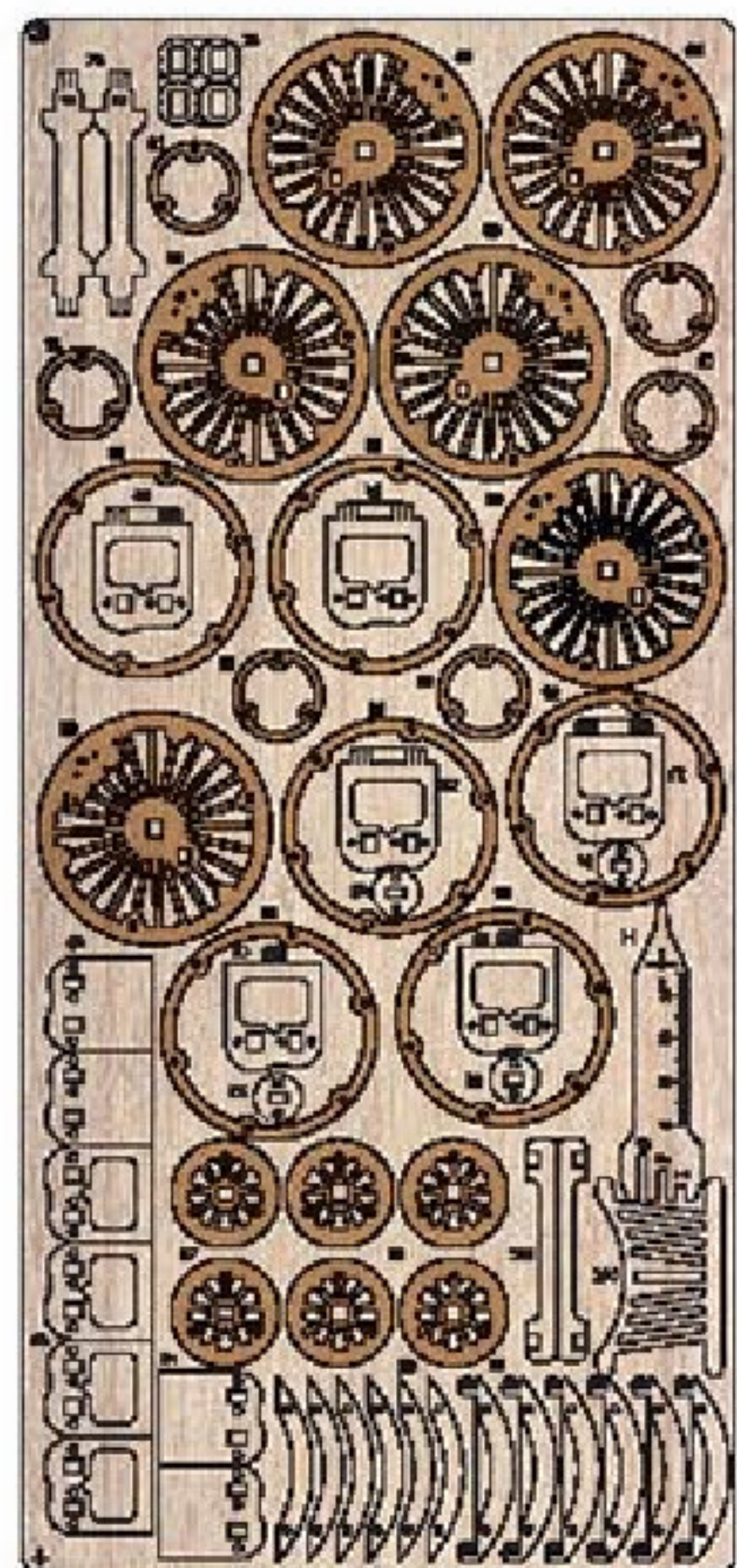

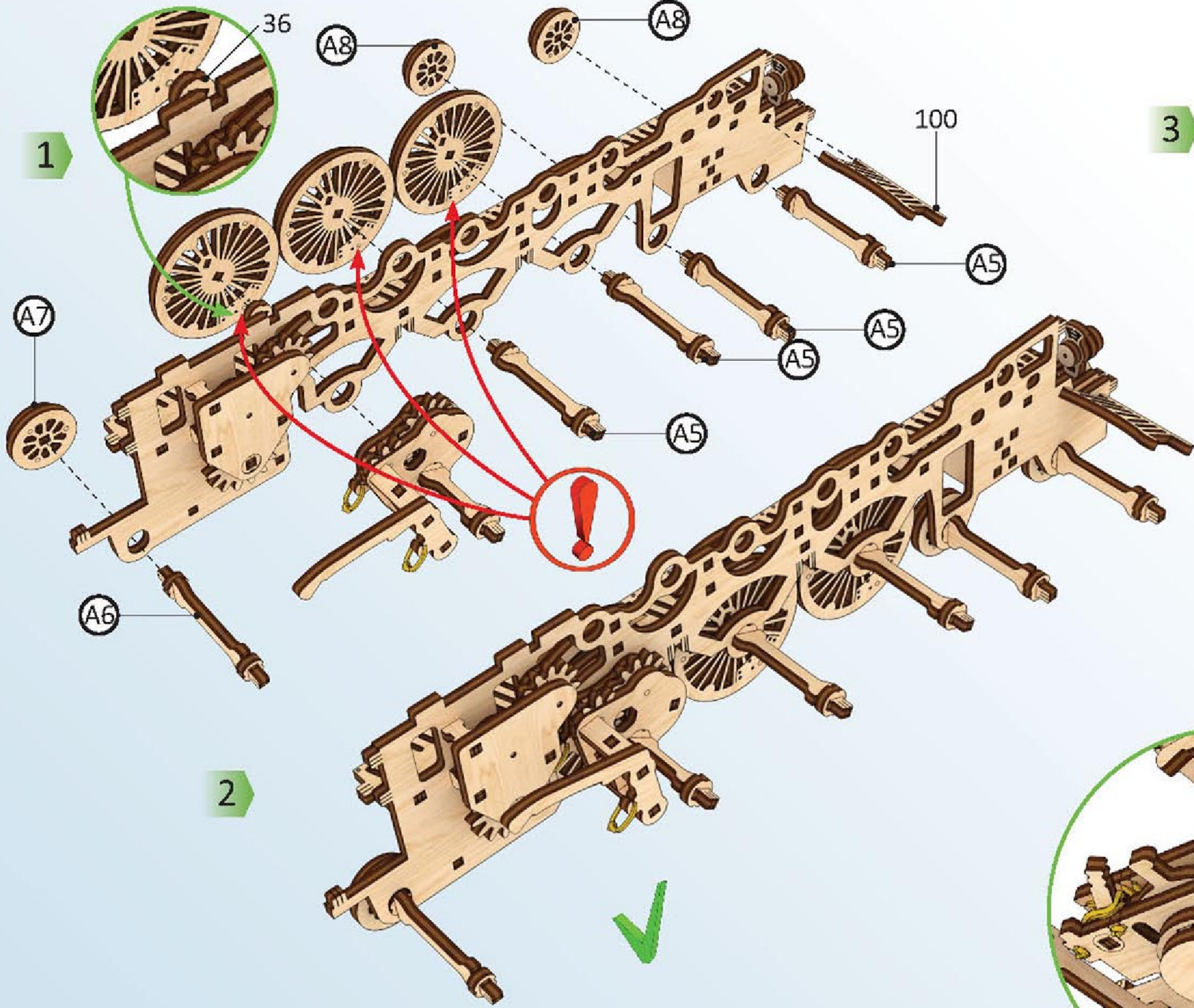
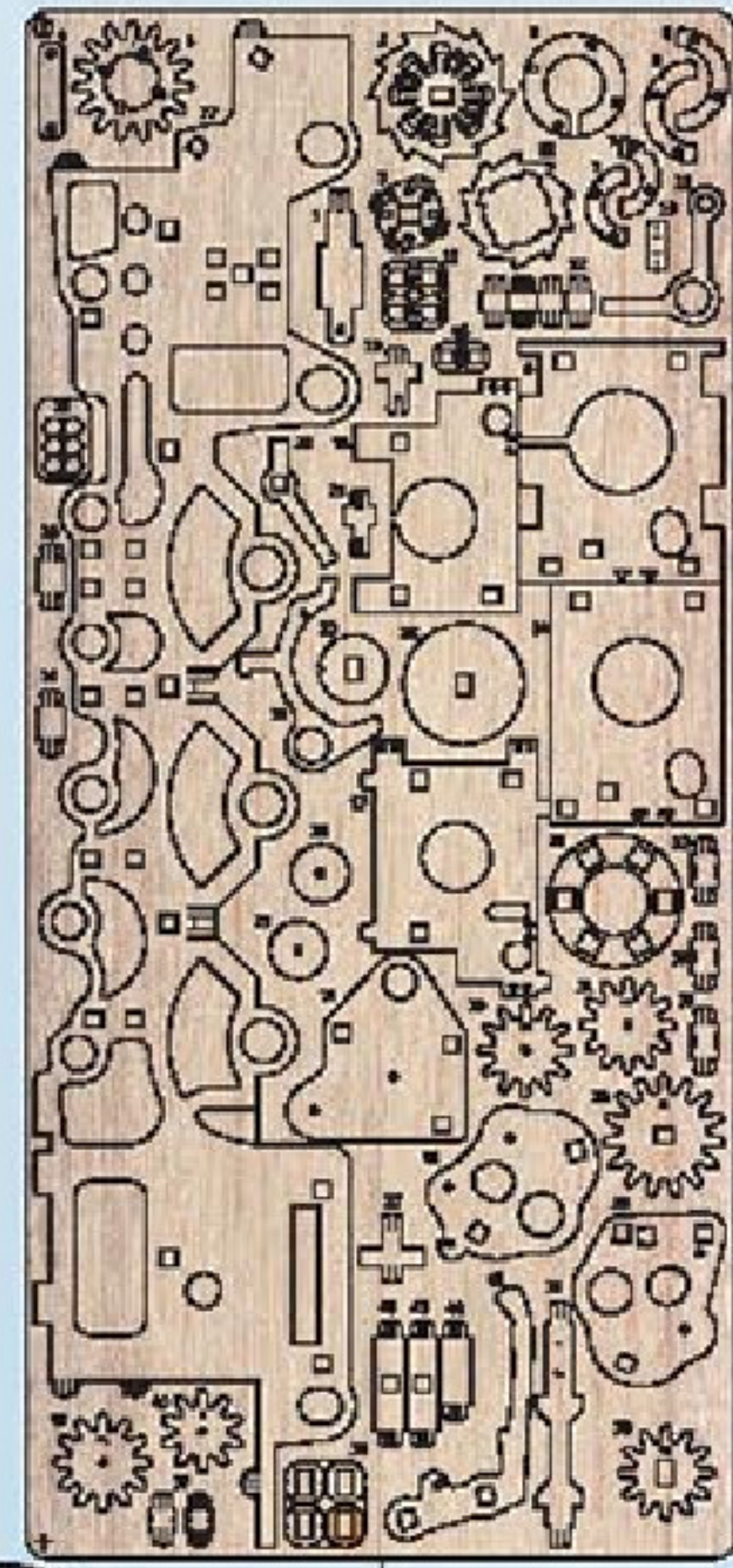
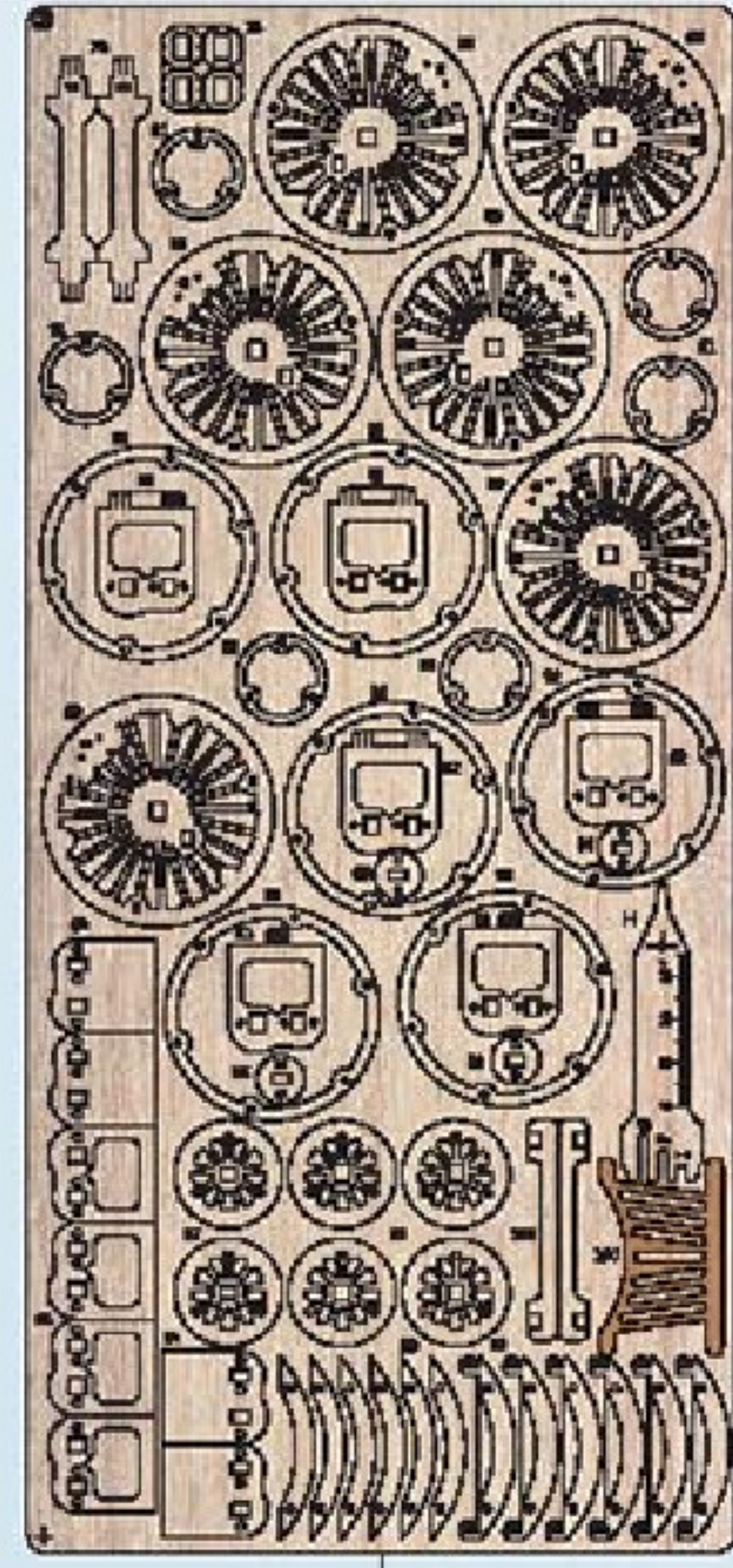

3

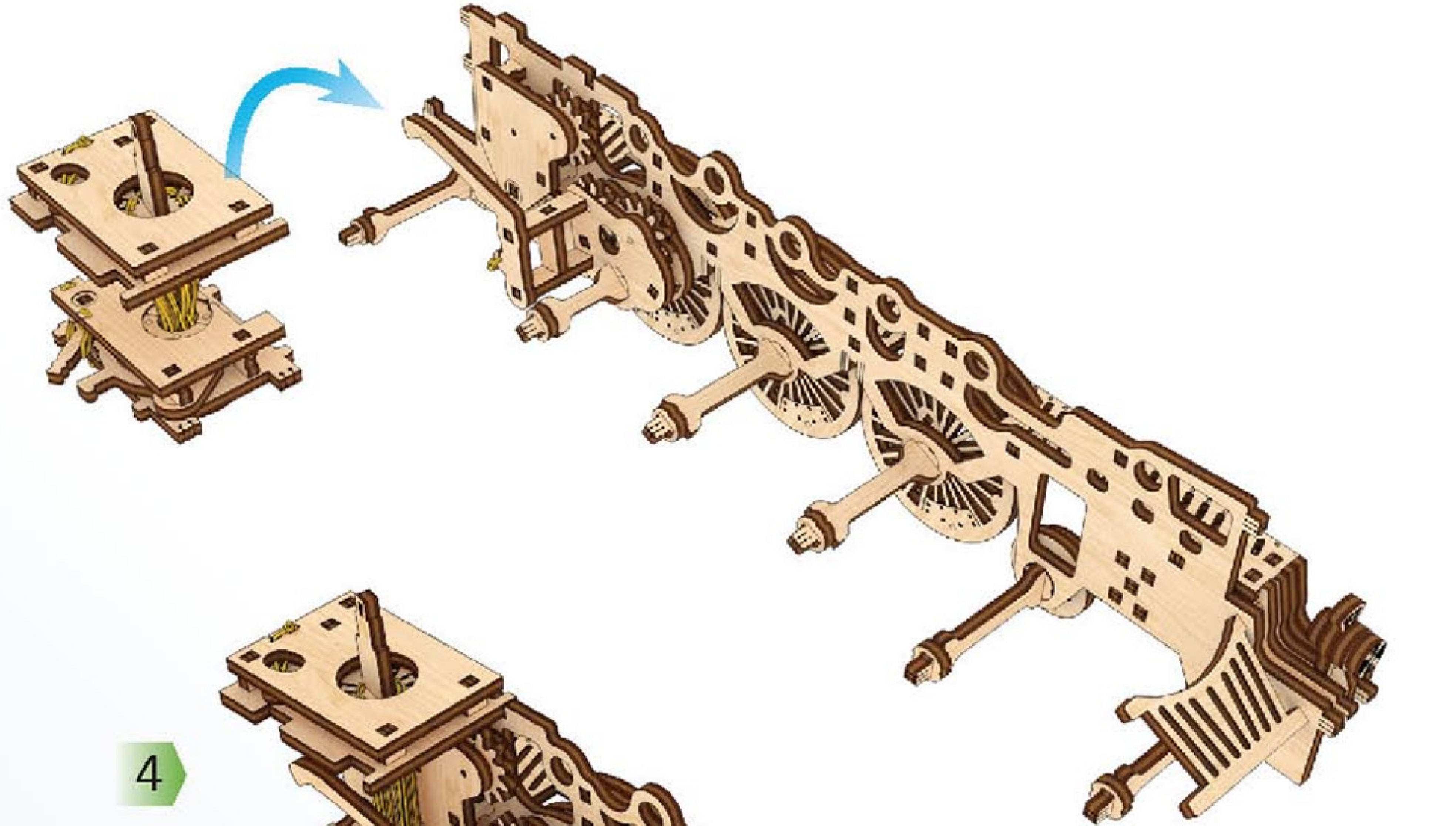

4

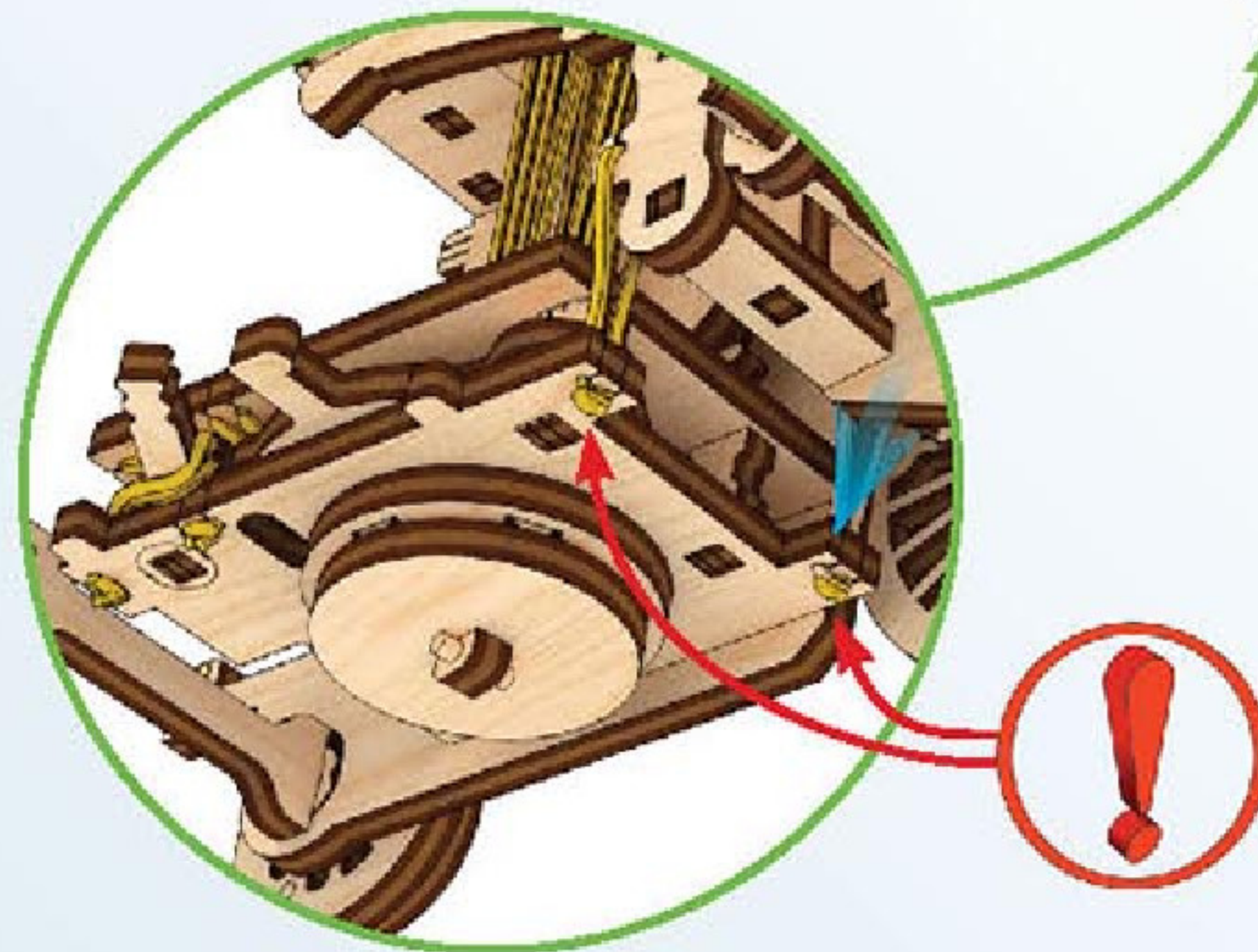

✓

✓

1

B1

4

2

3

A7

5

A8

A8

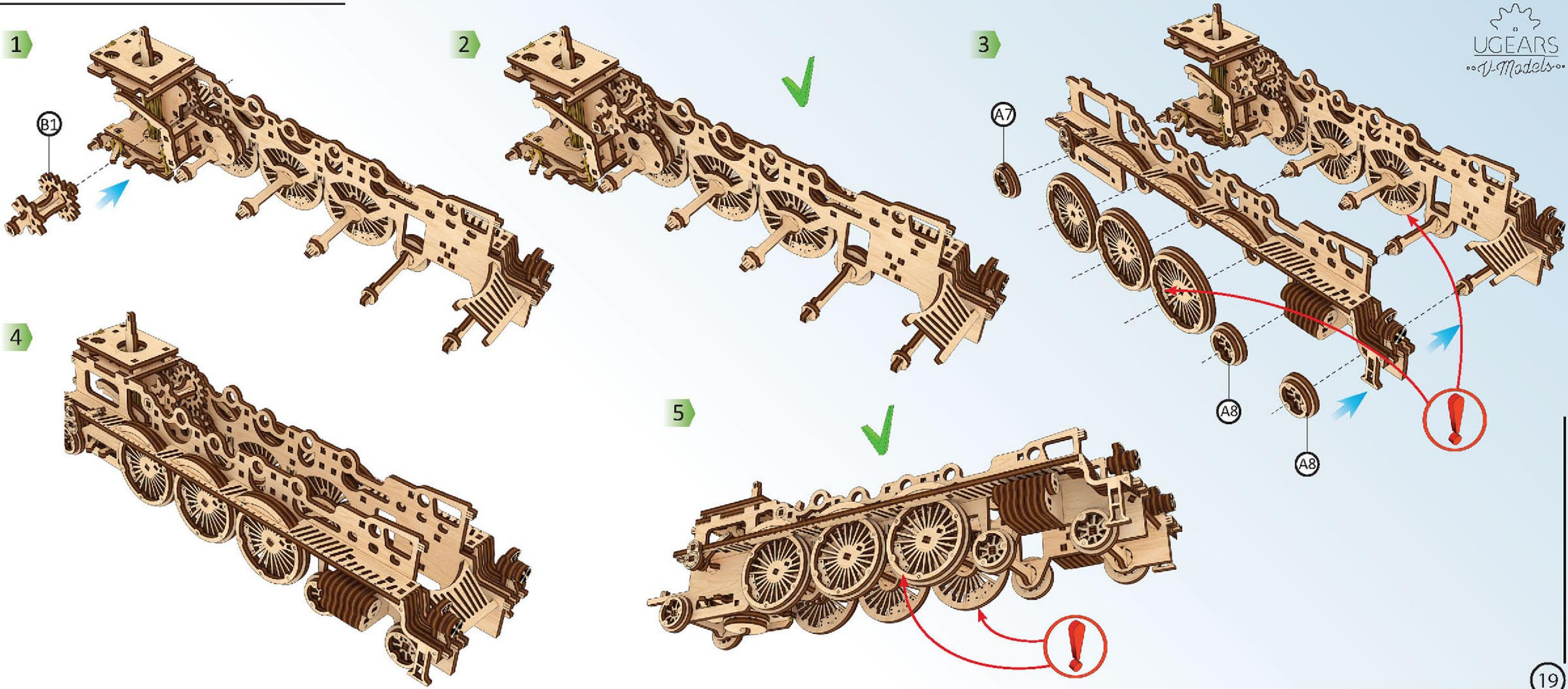

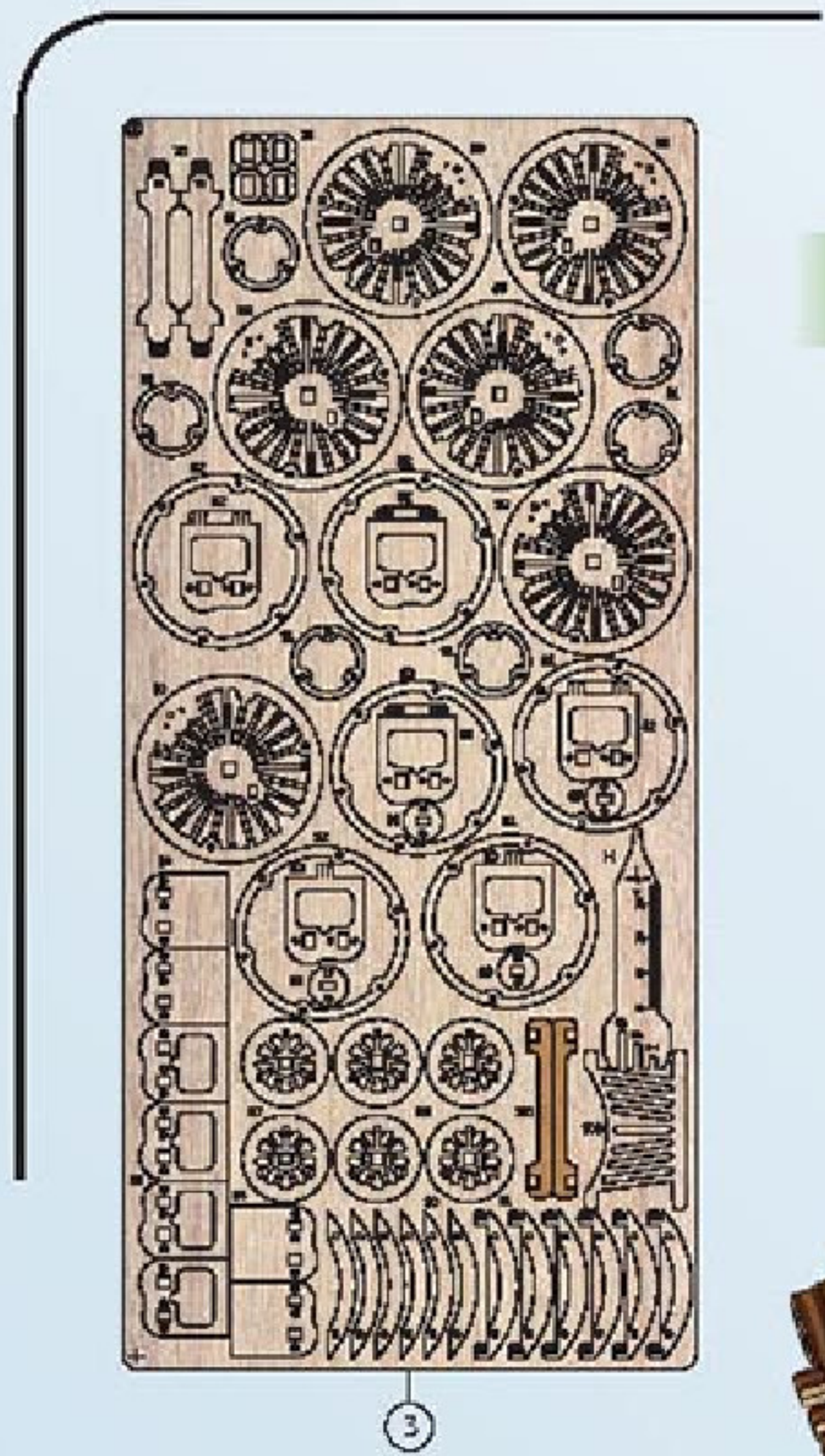

1

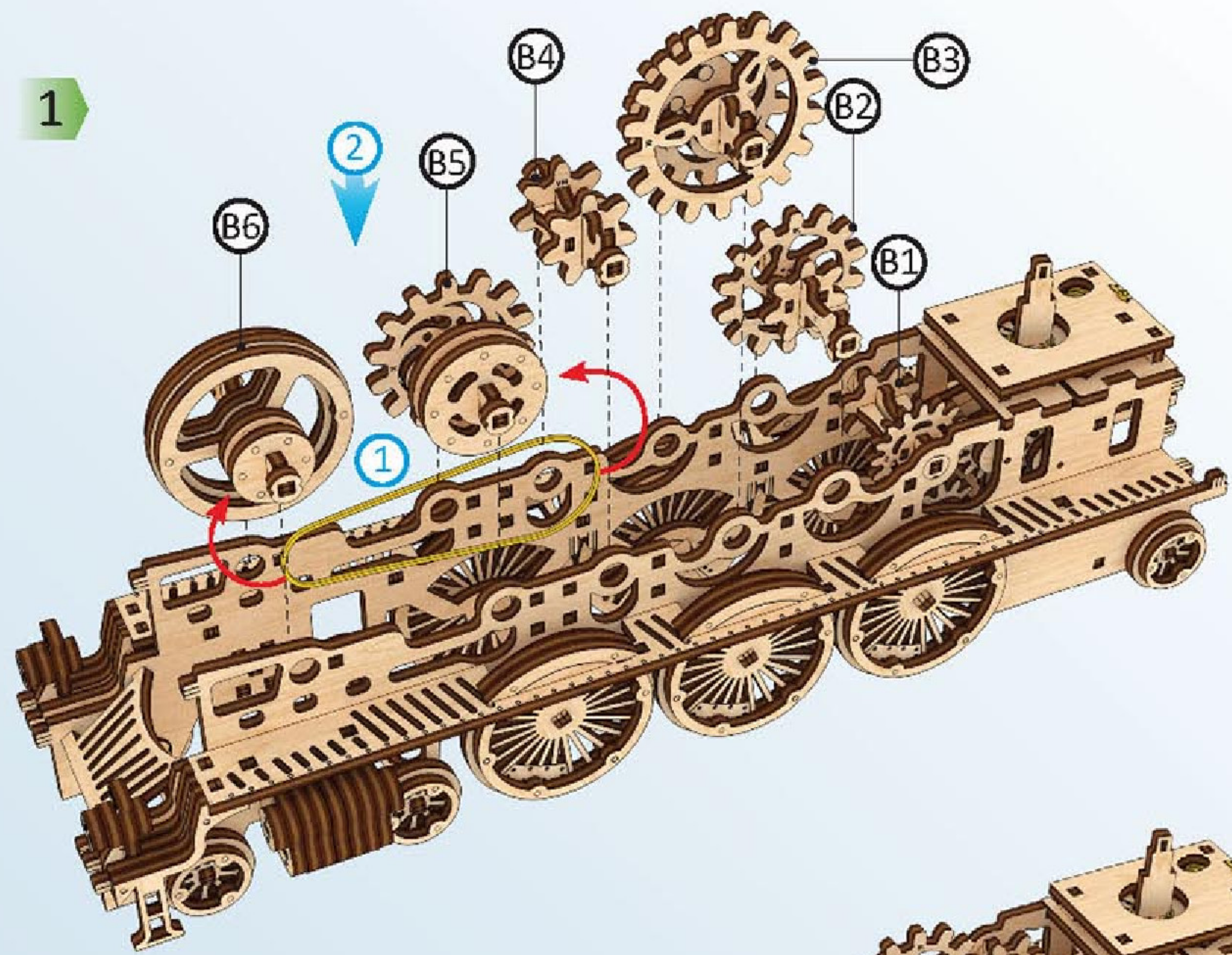

2



3

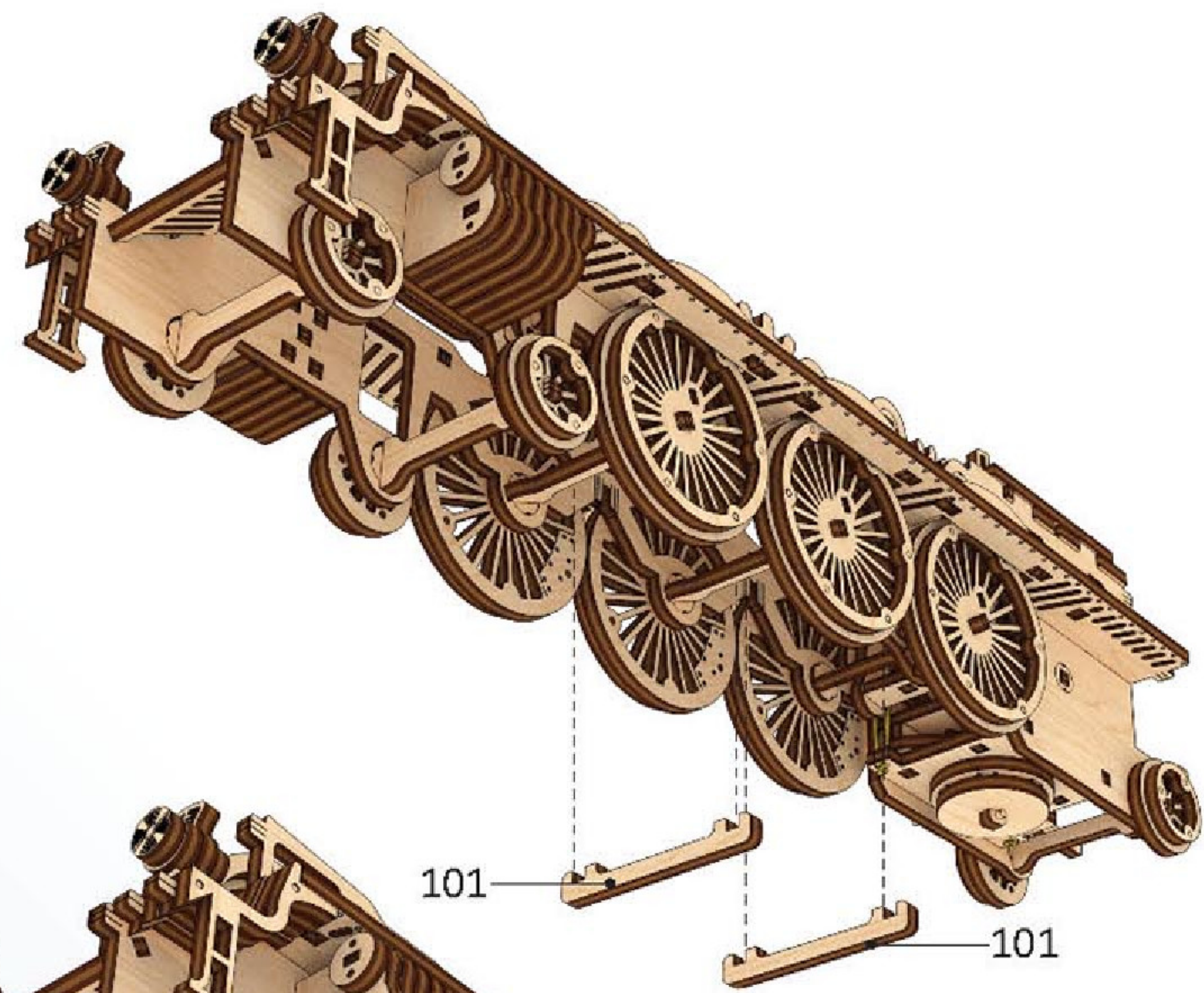

4

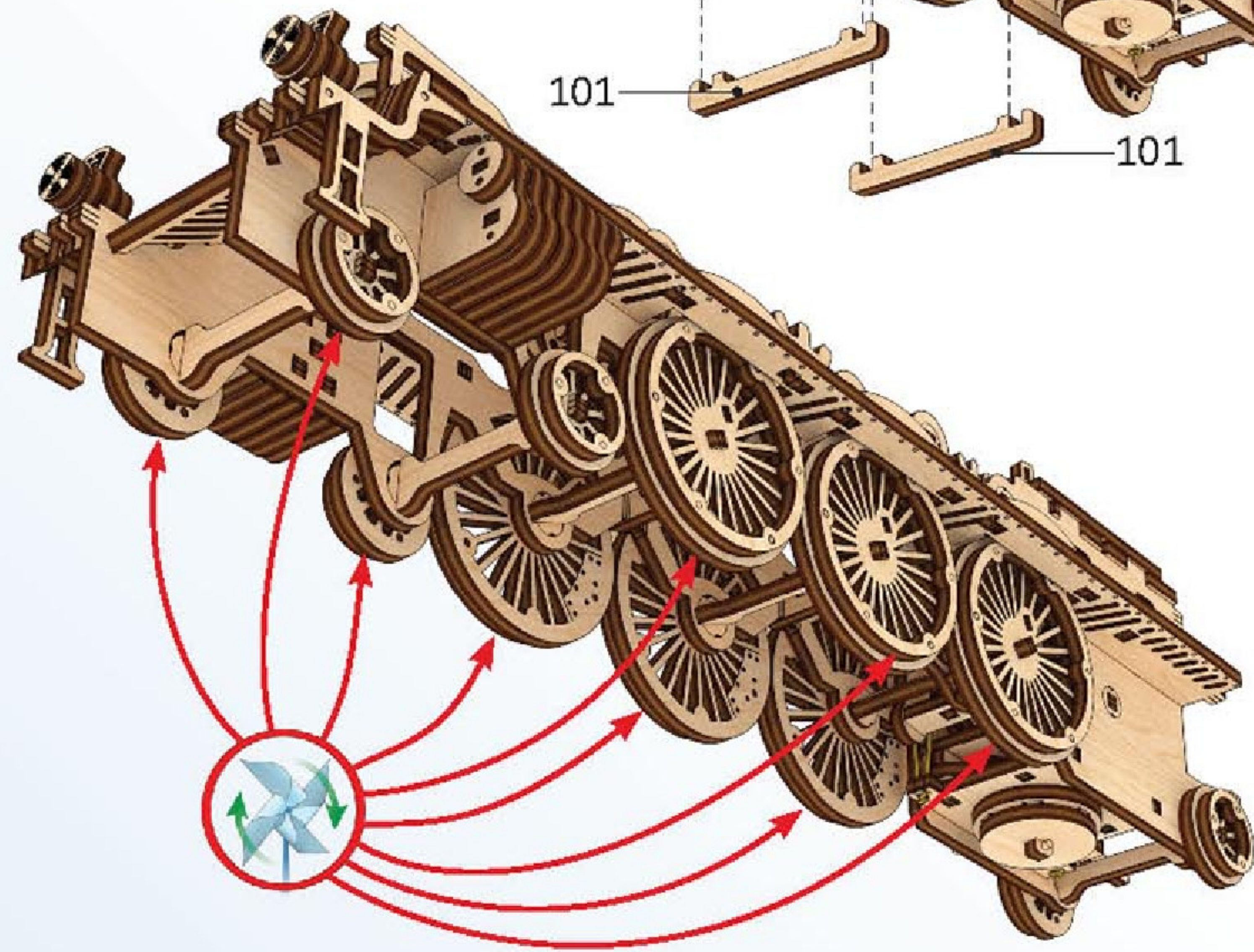

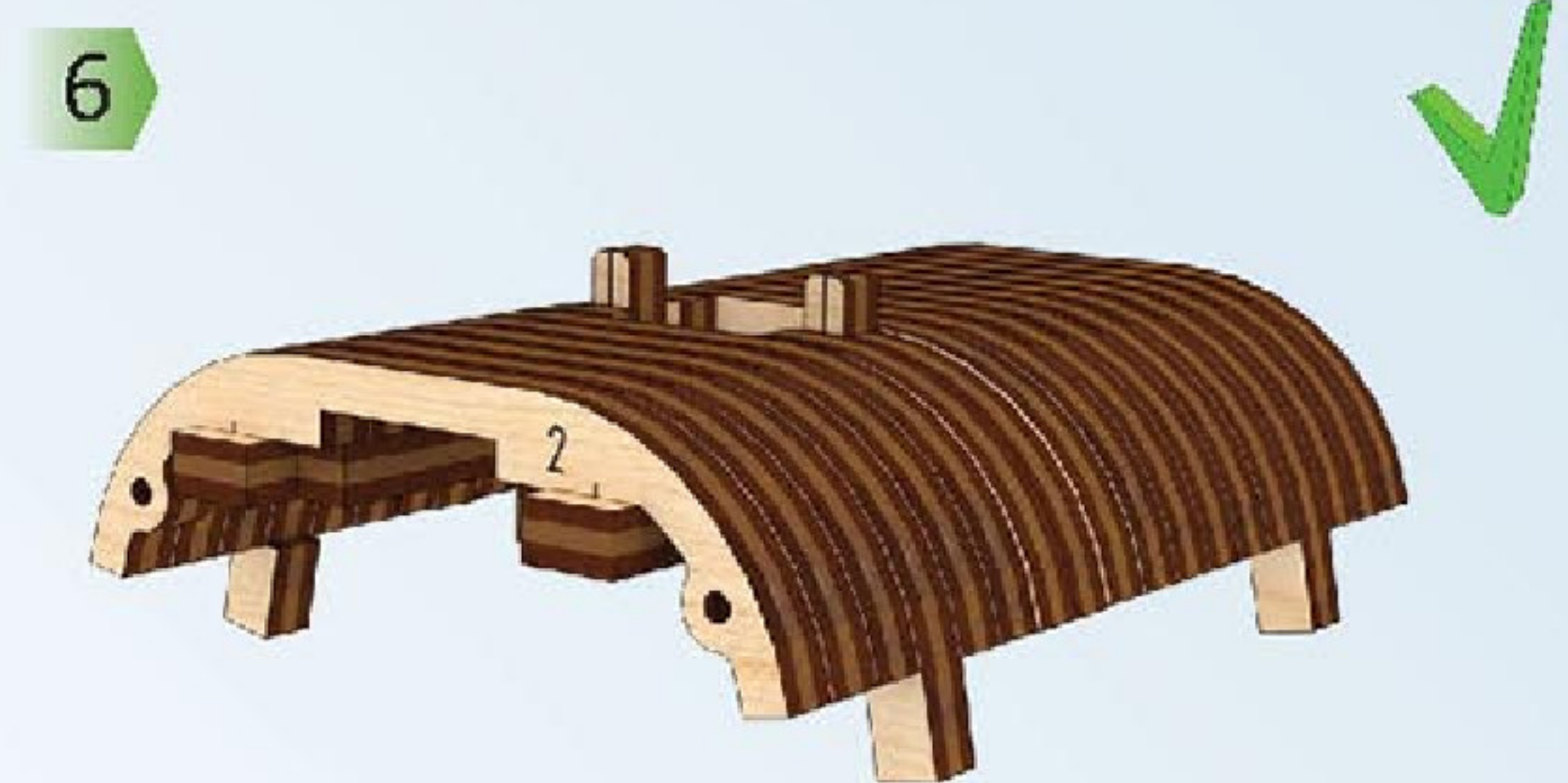
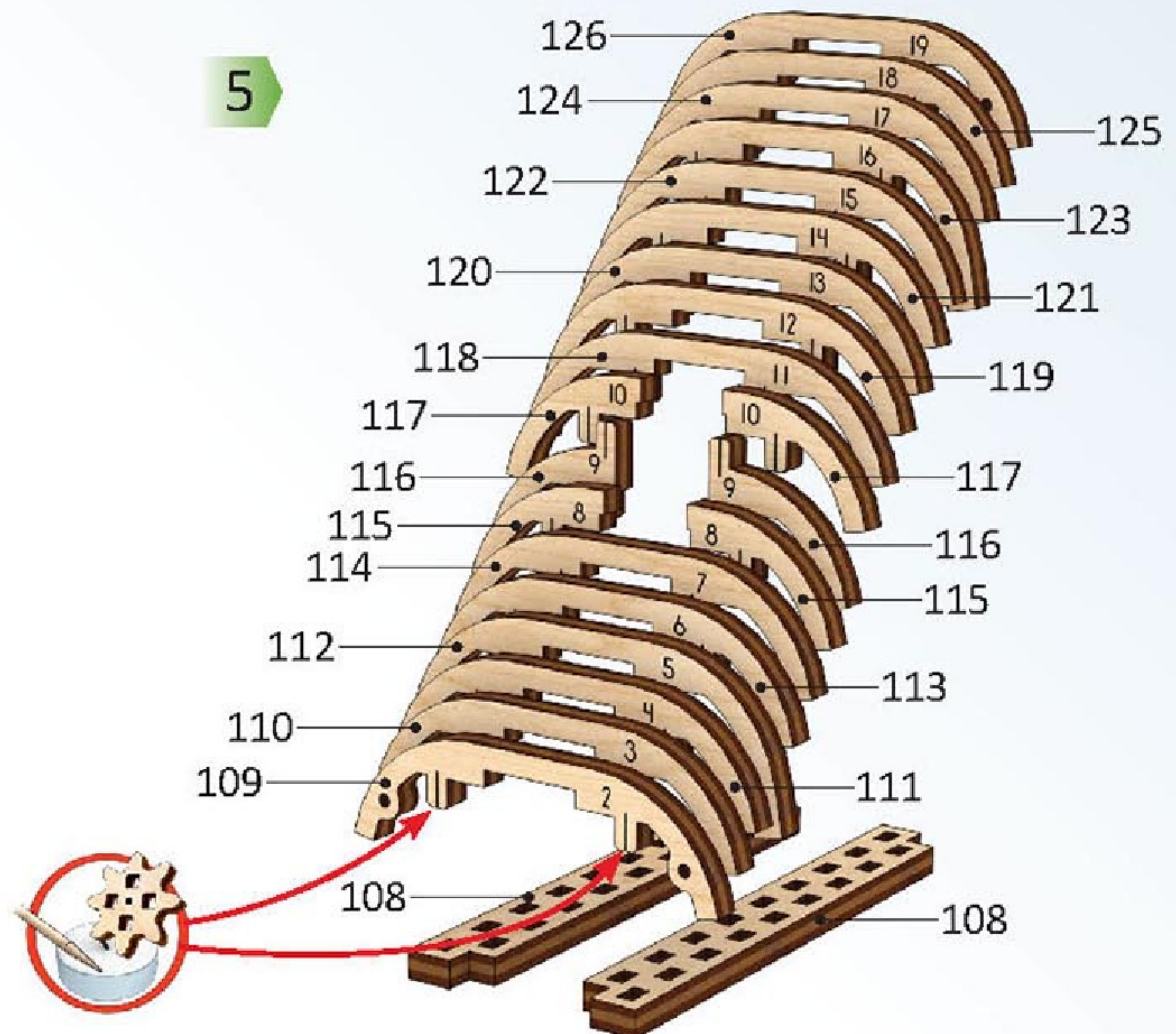
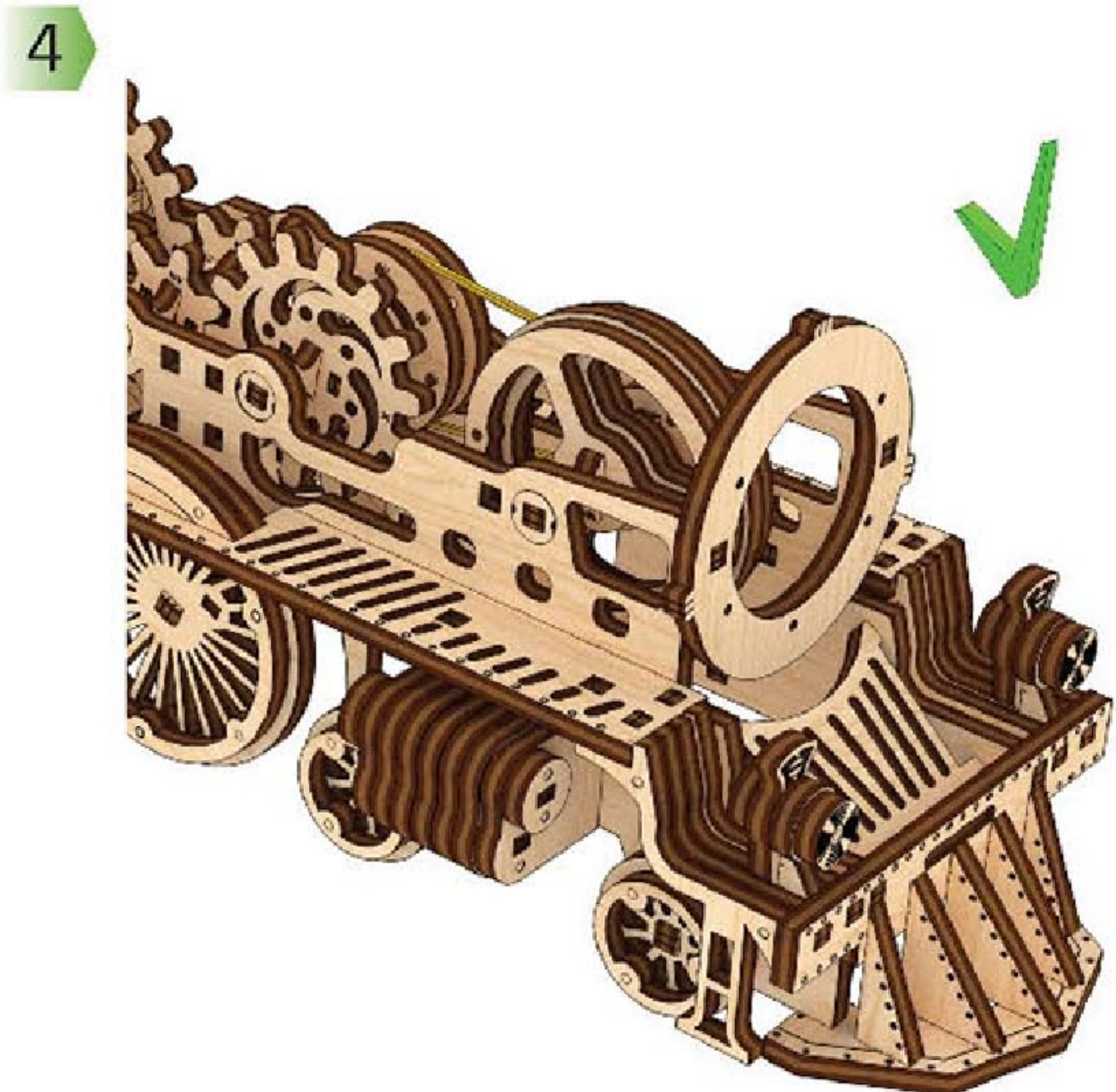
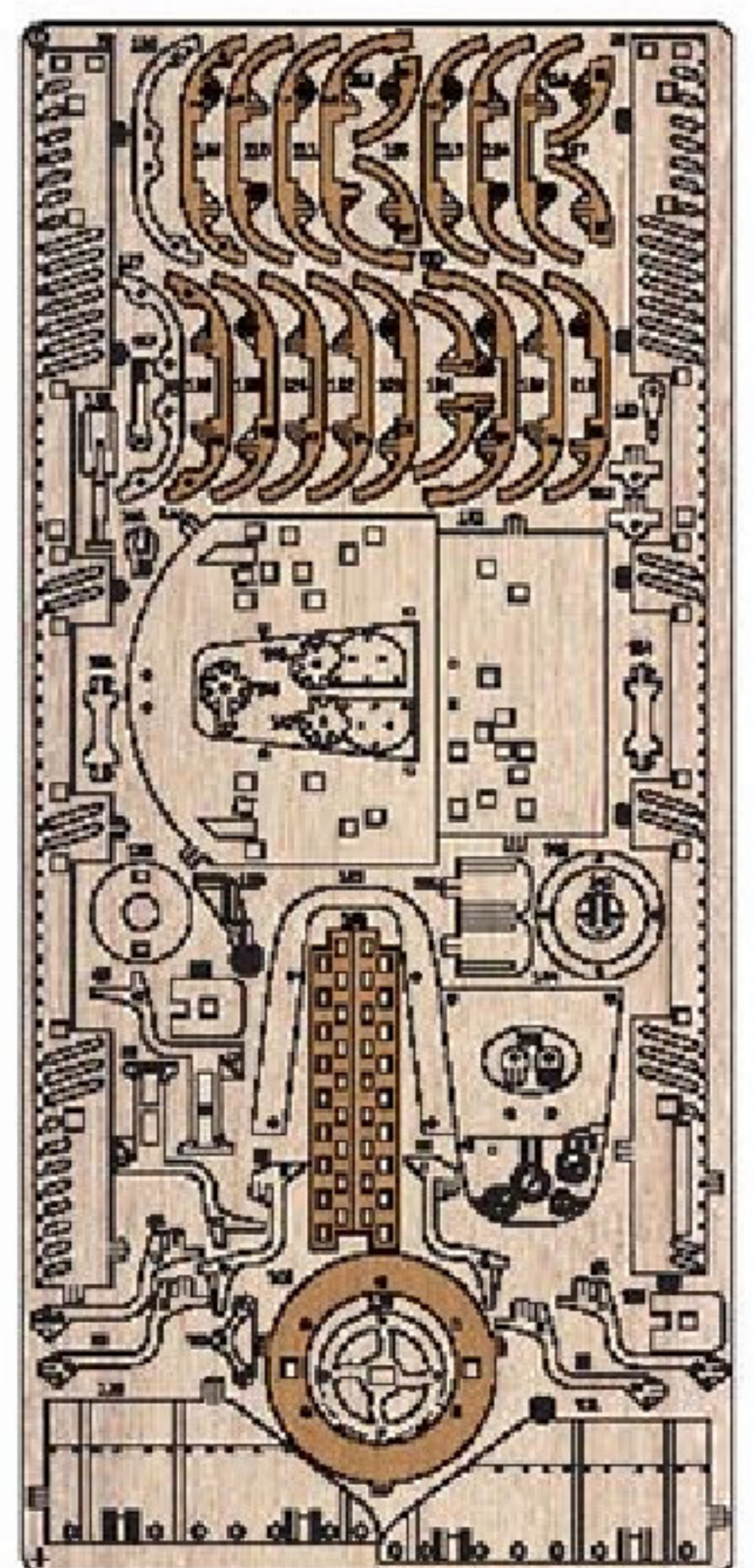
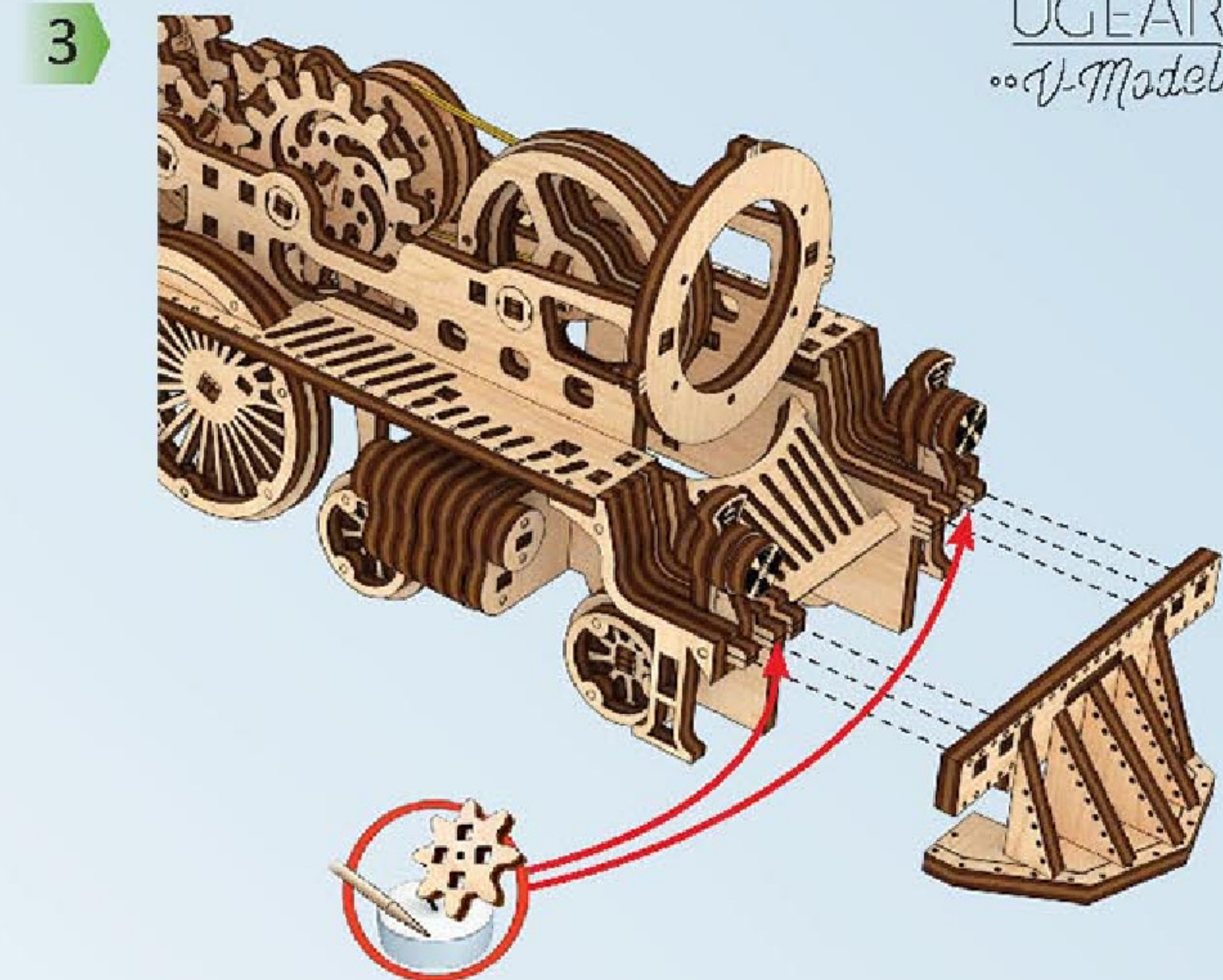
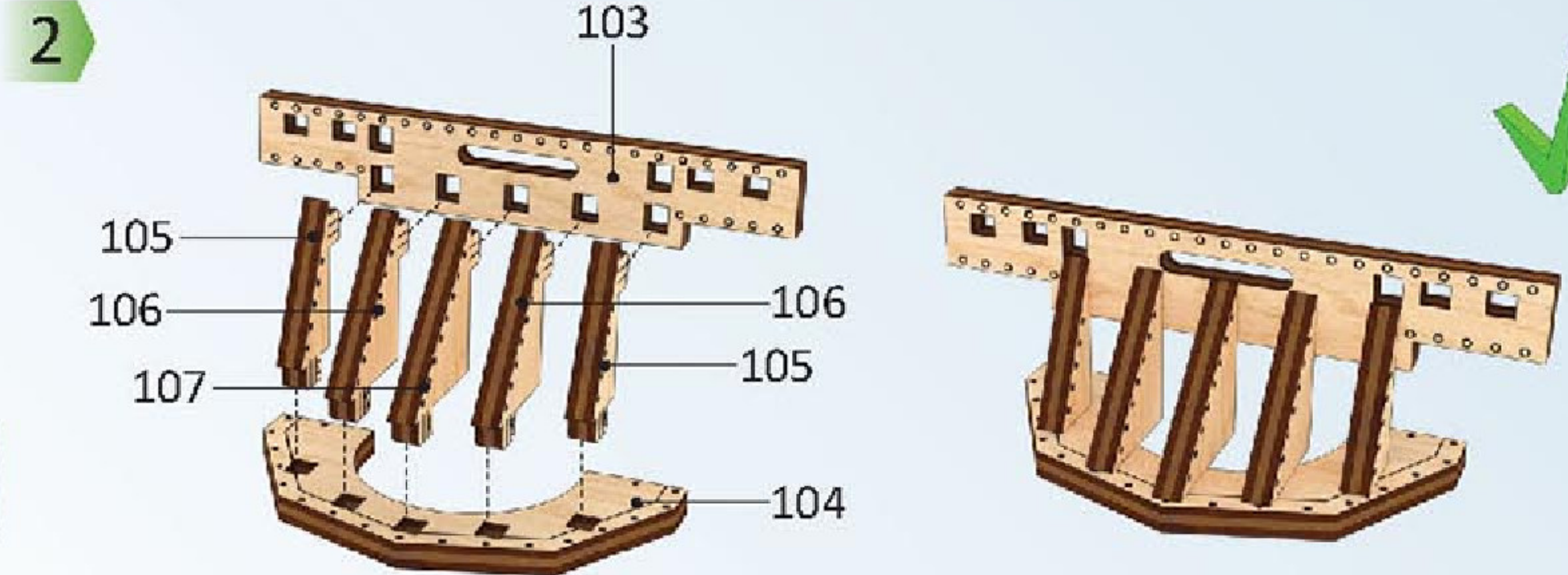
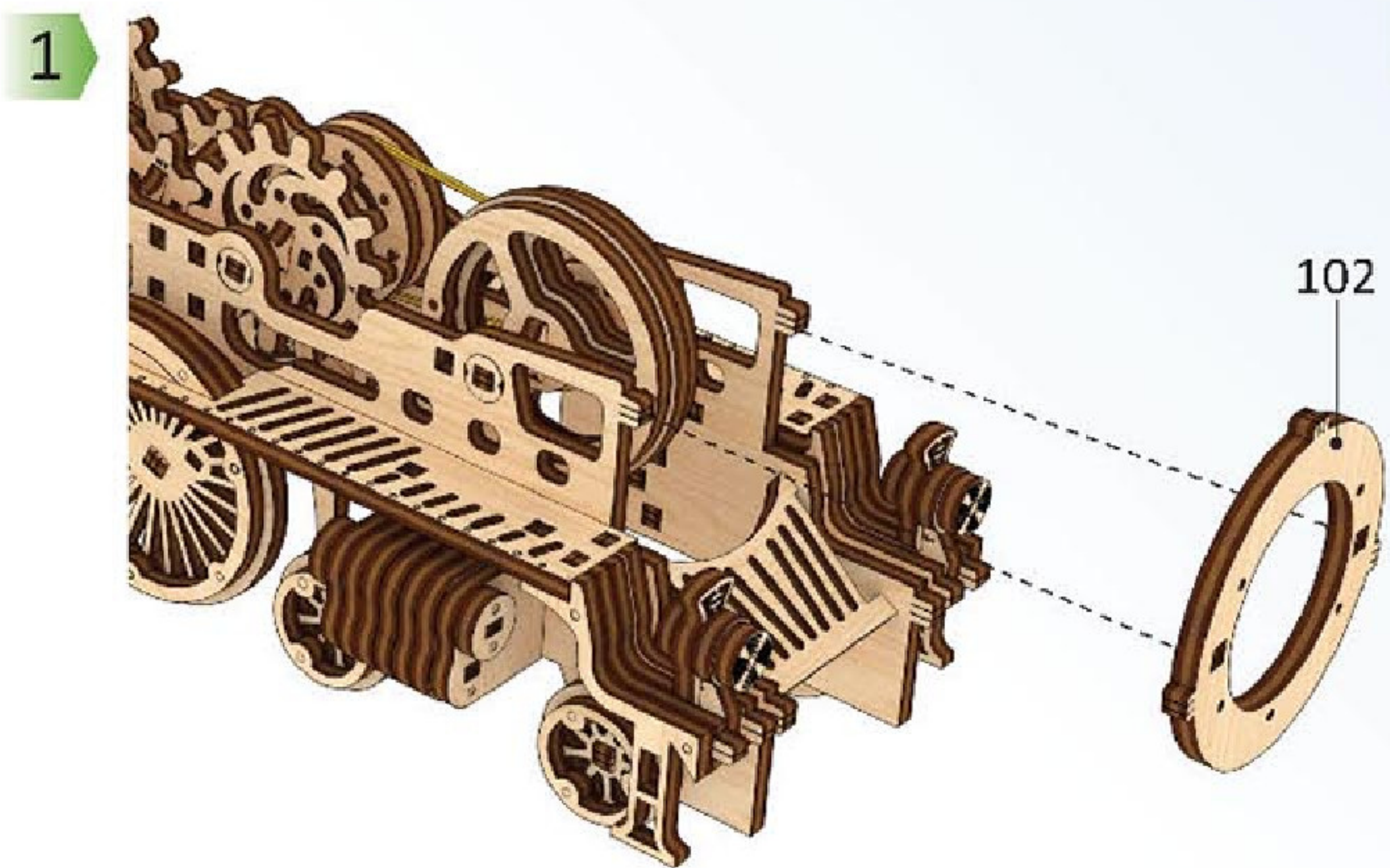
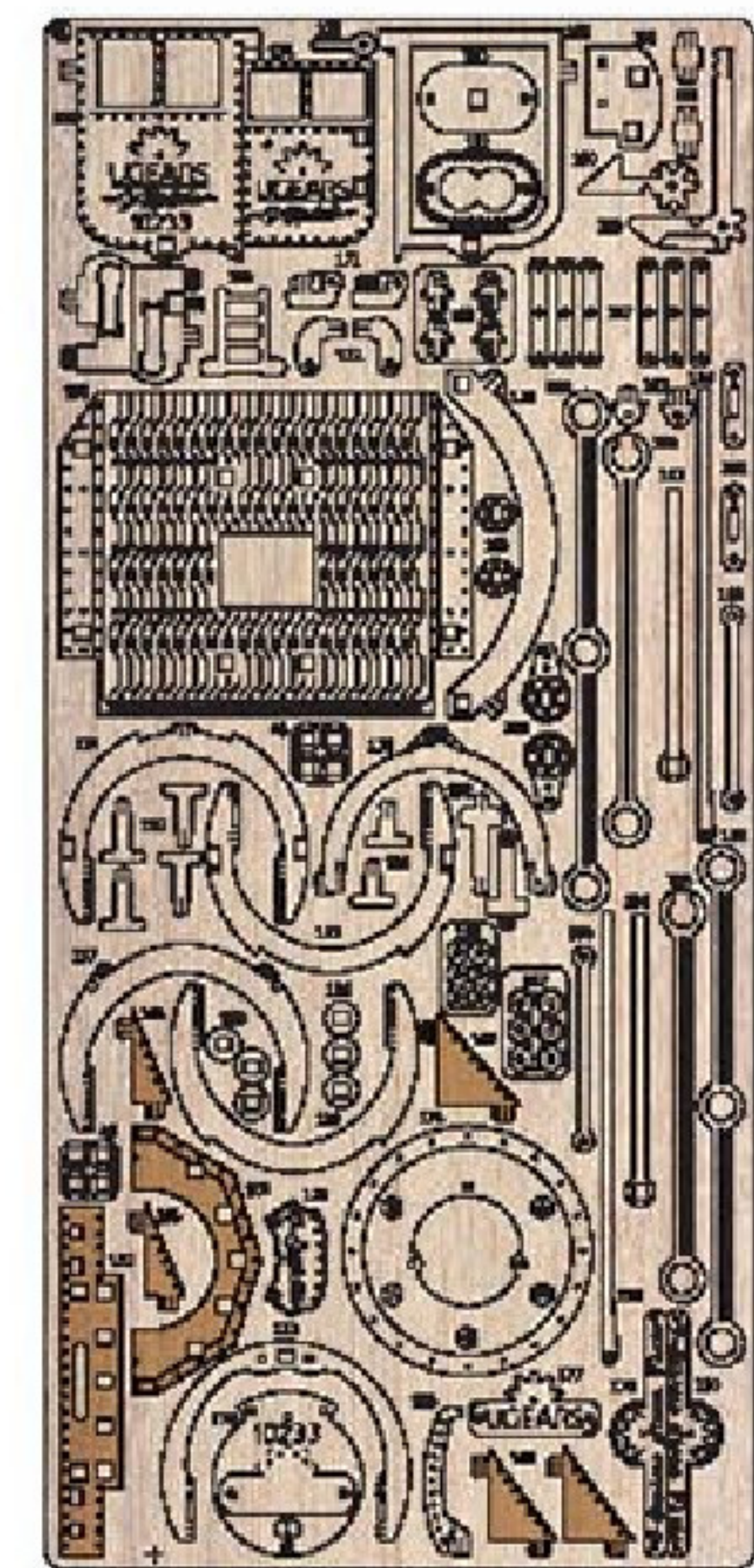

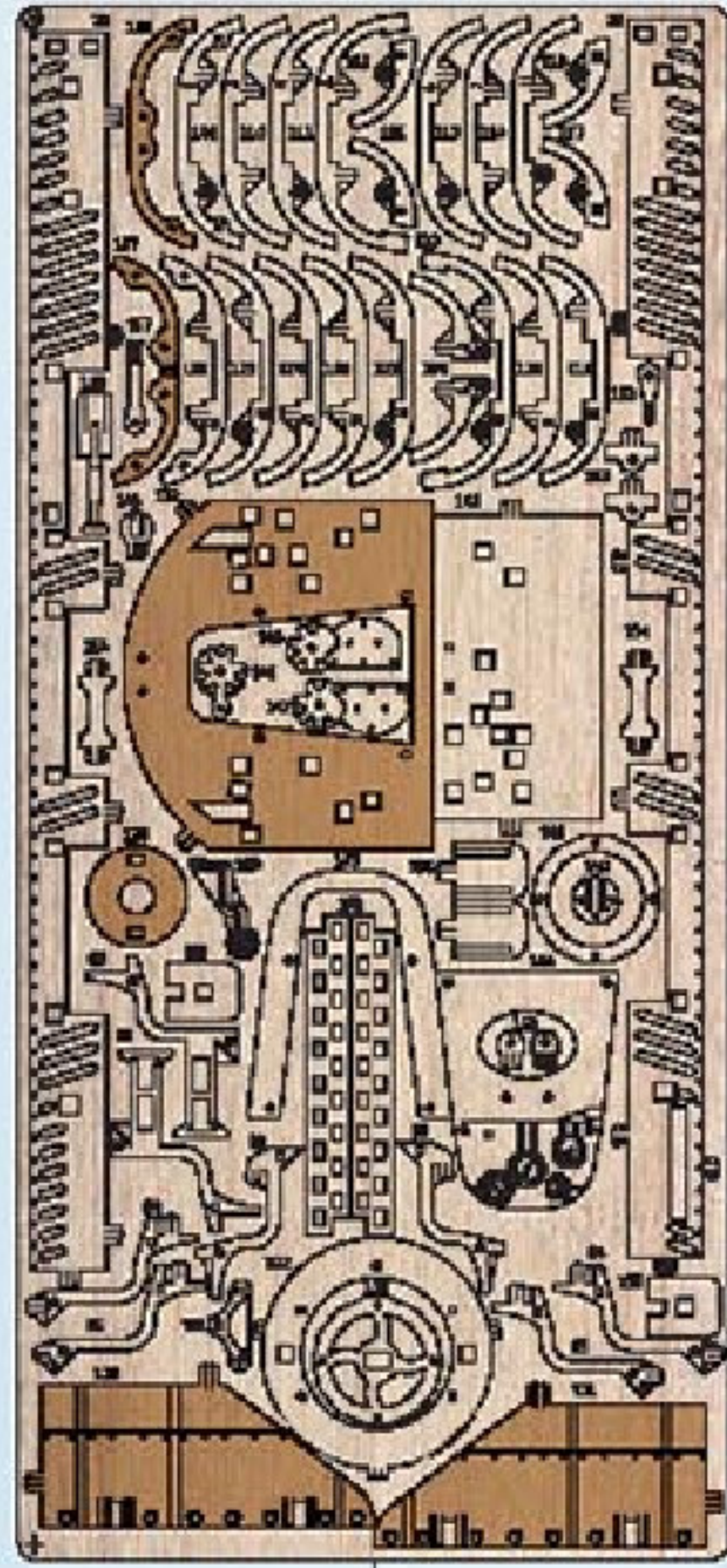

4

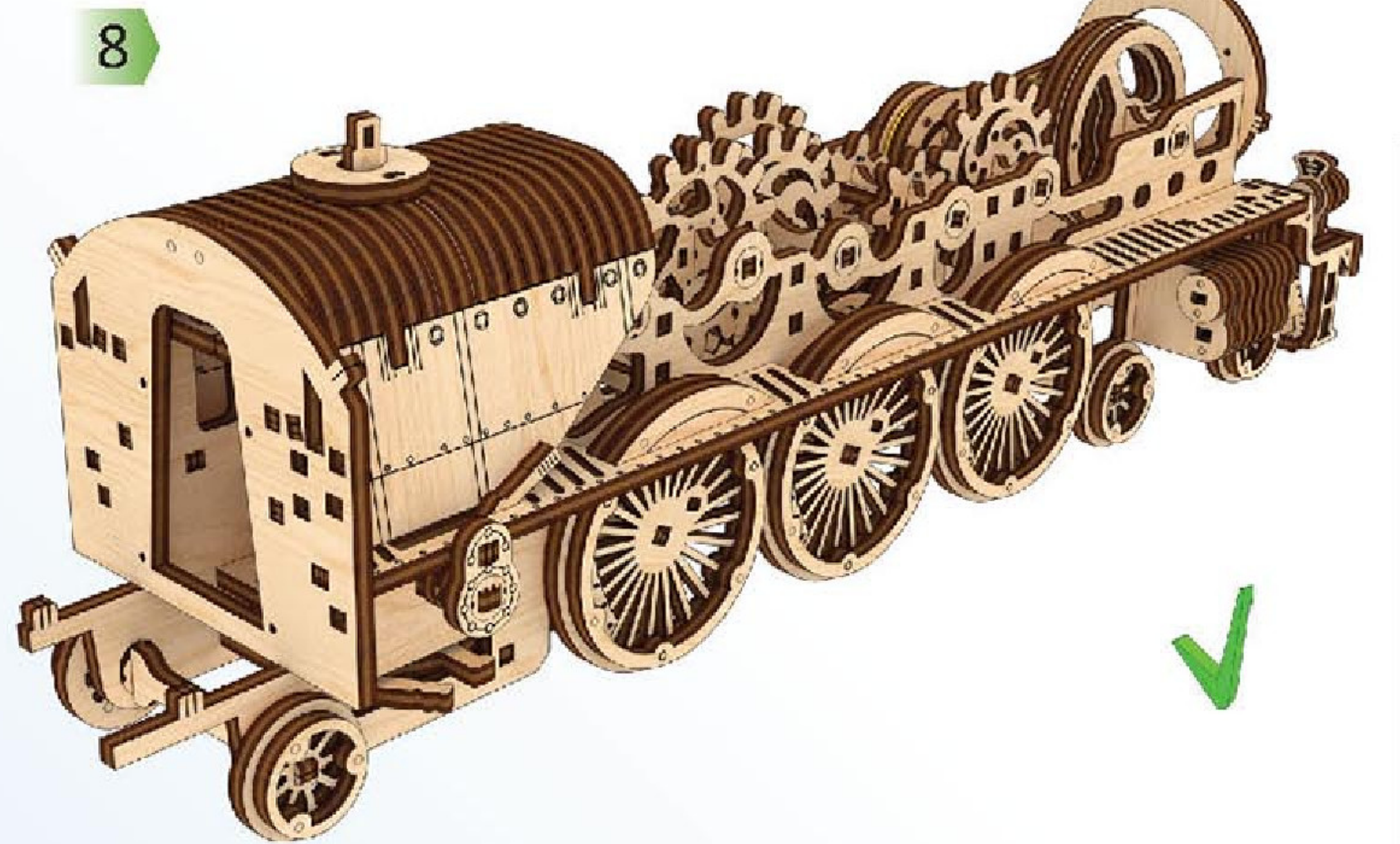
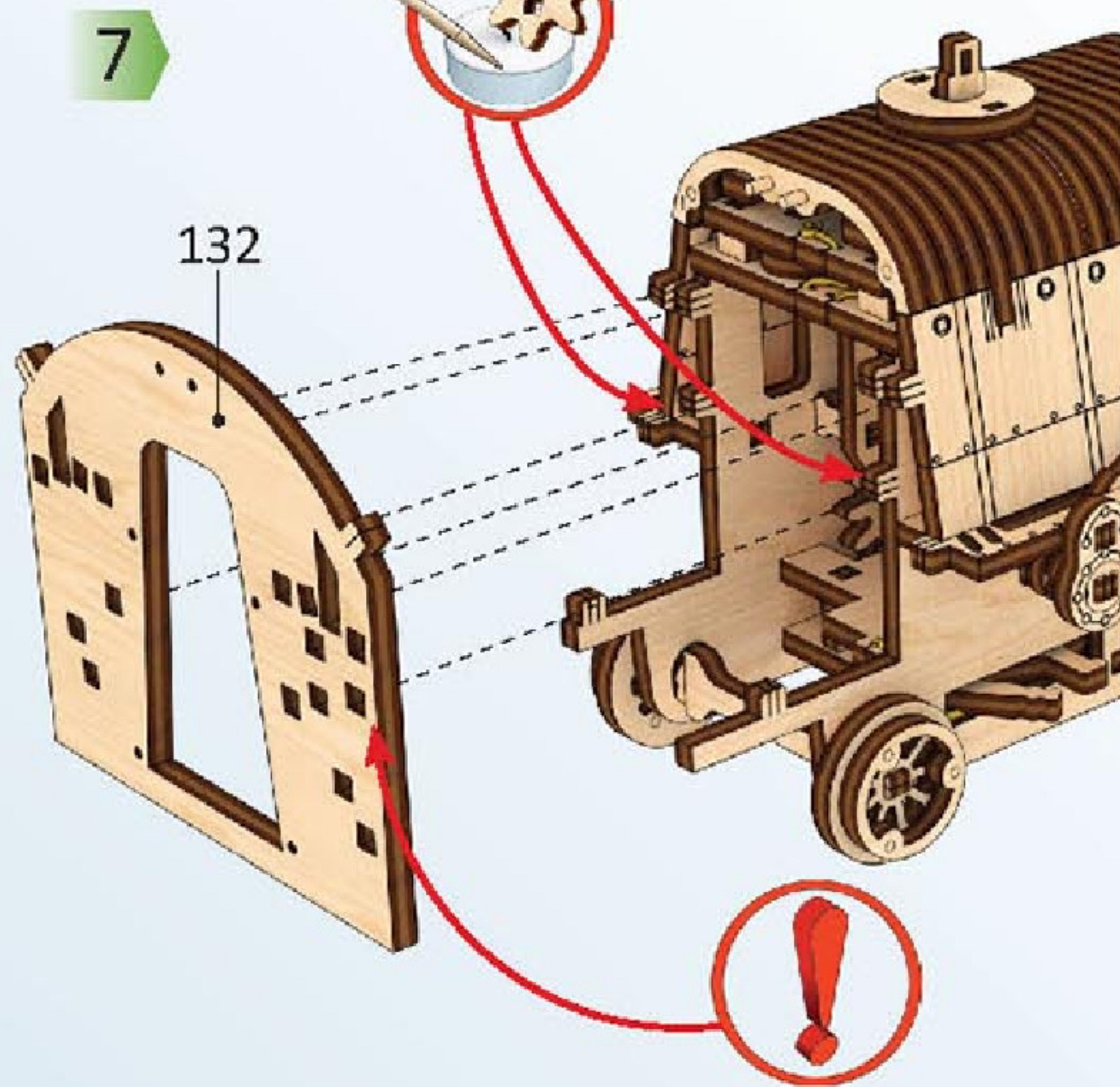
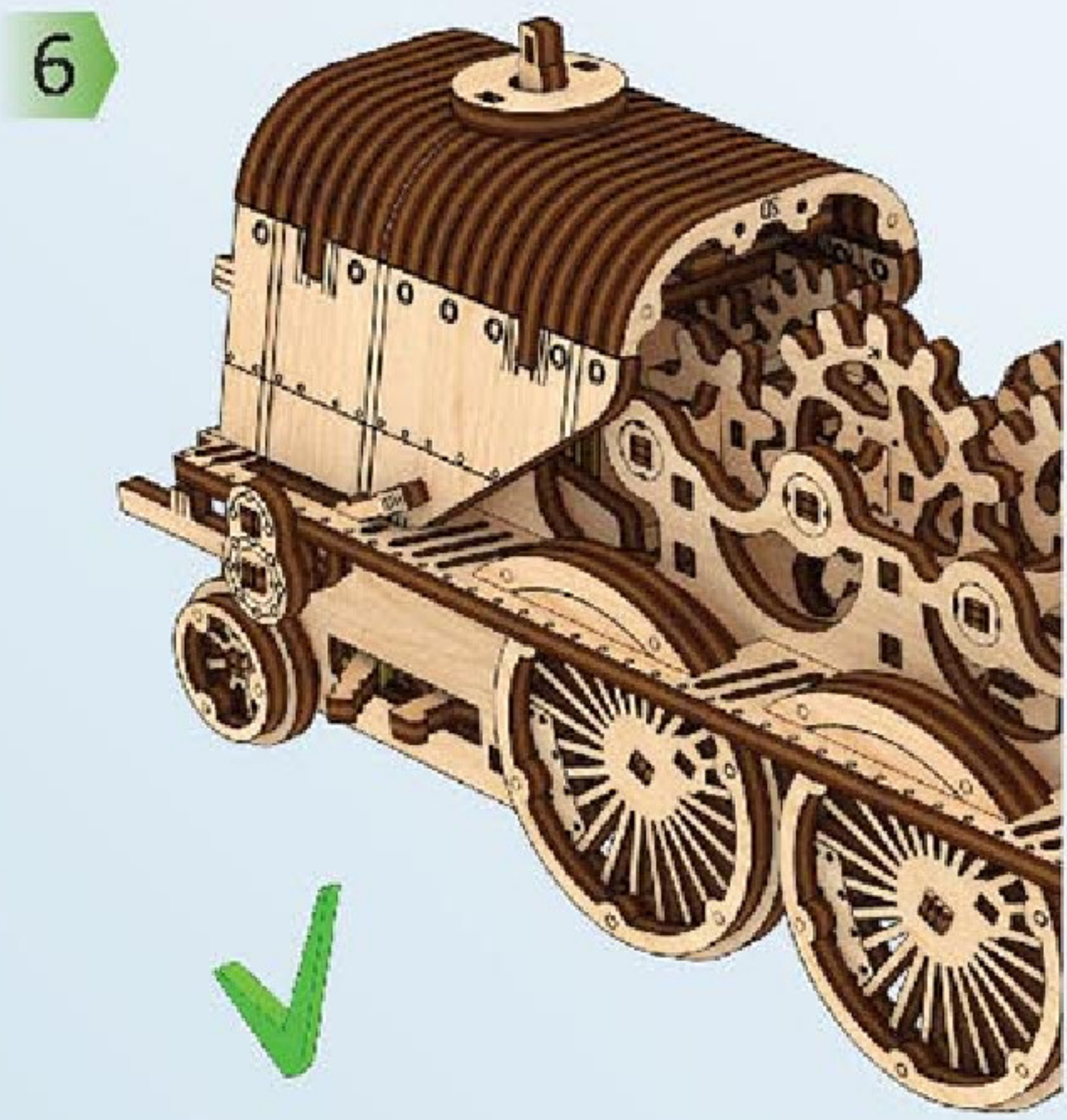
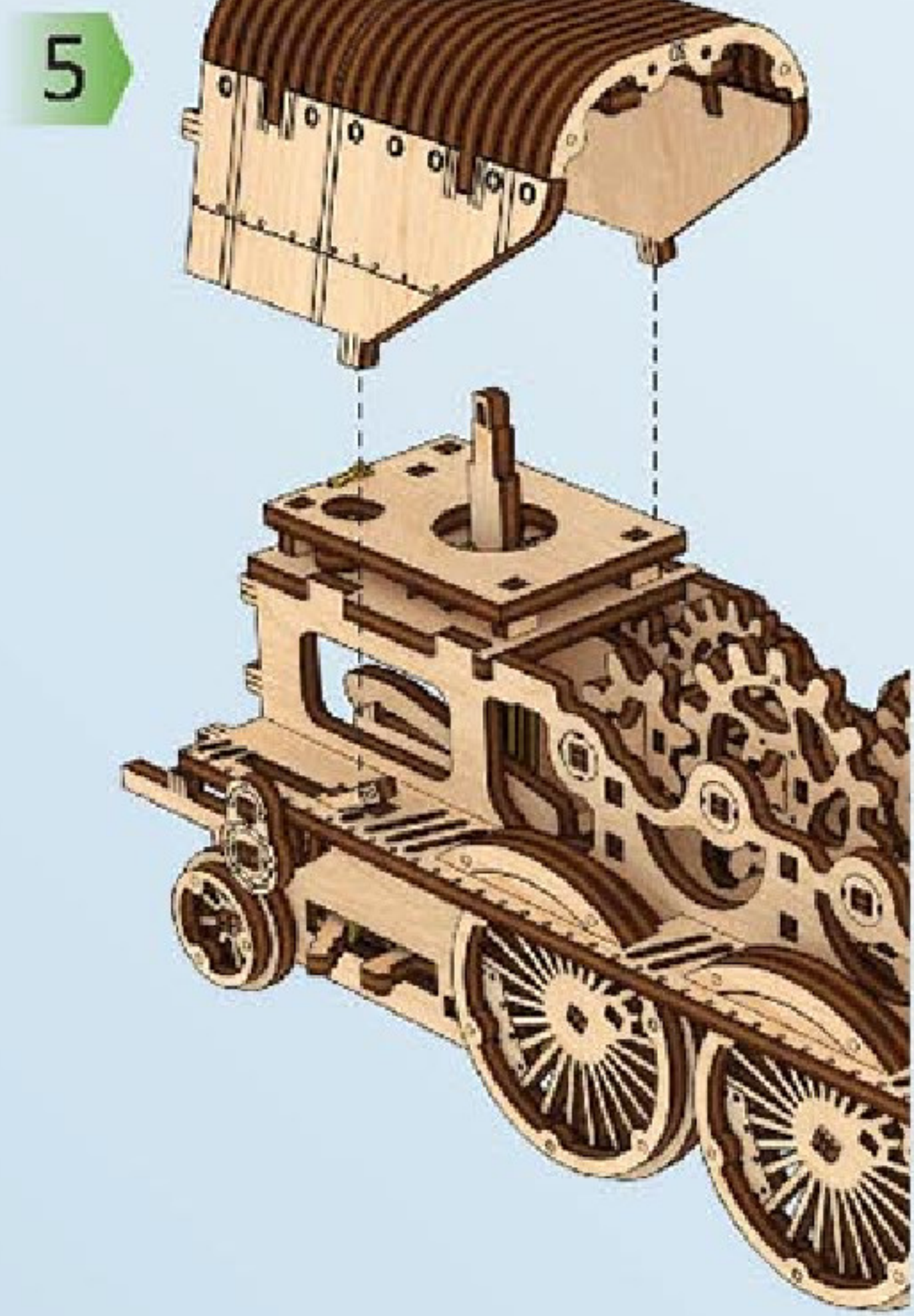
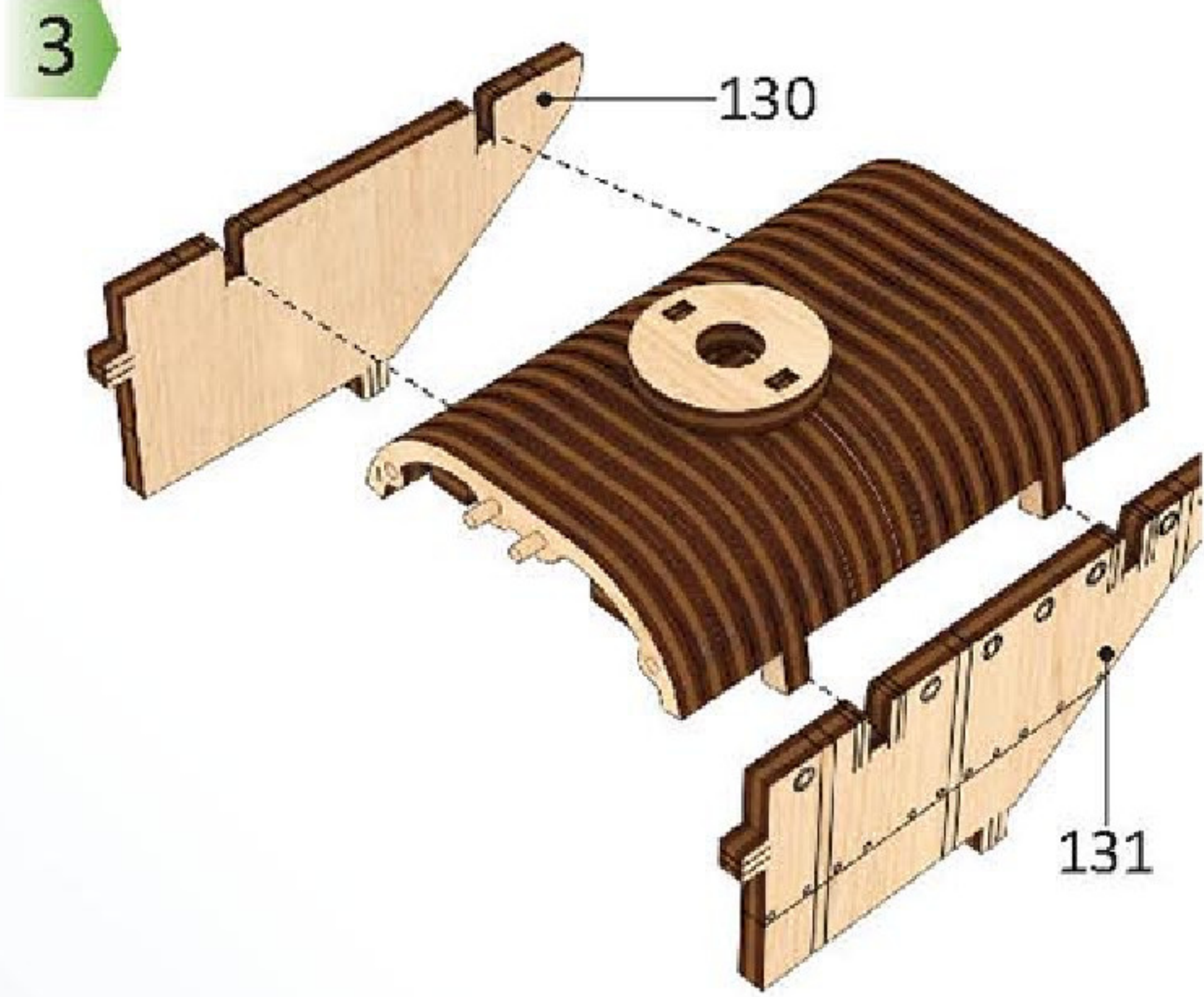
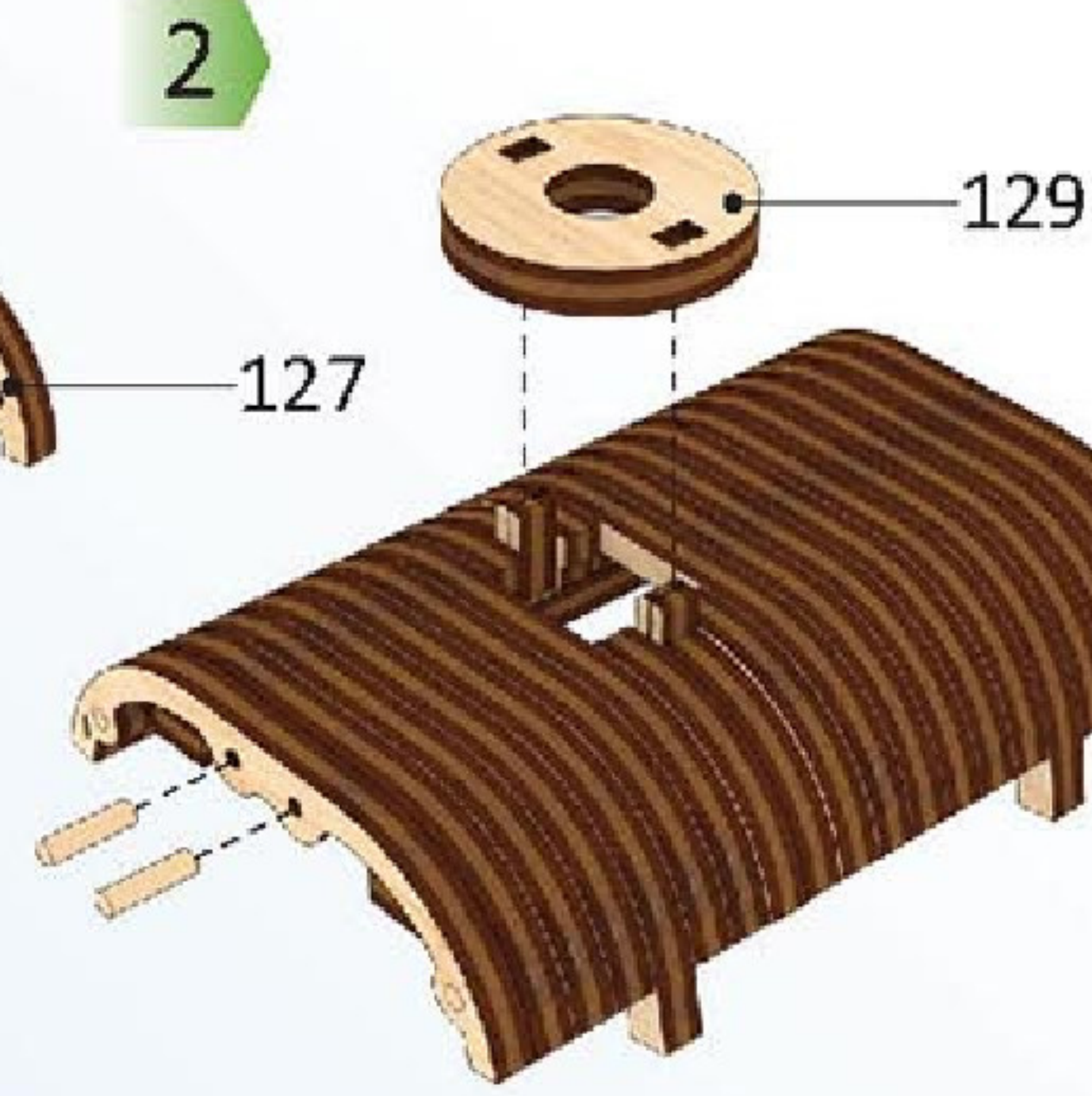
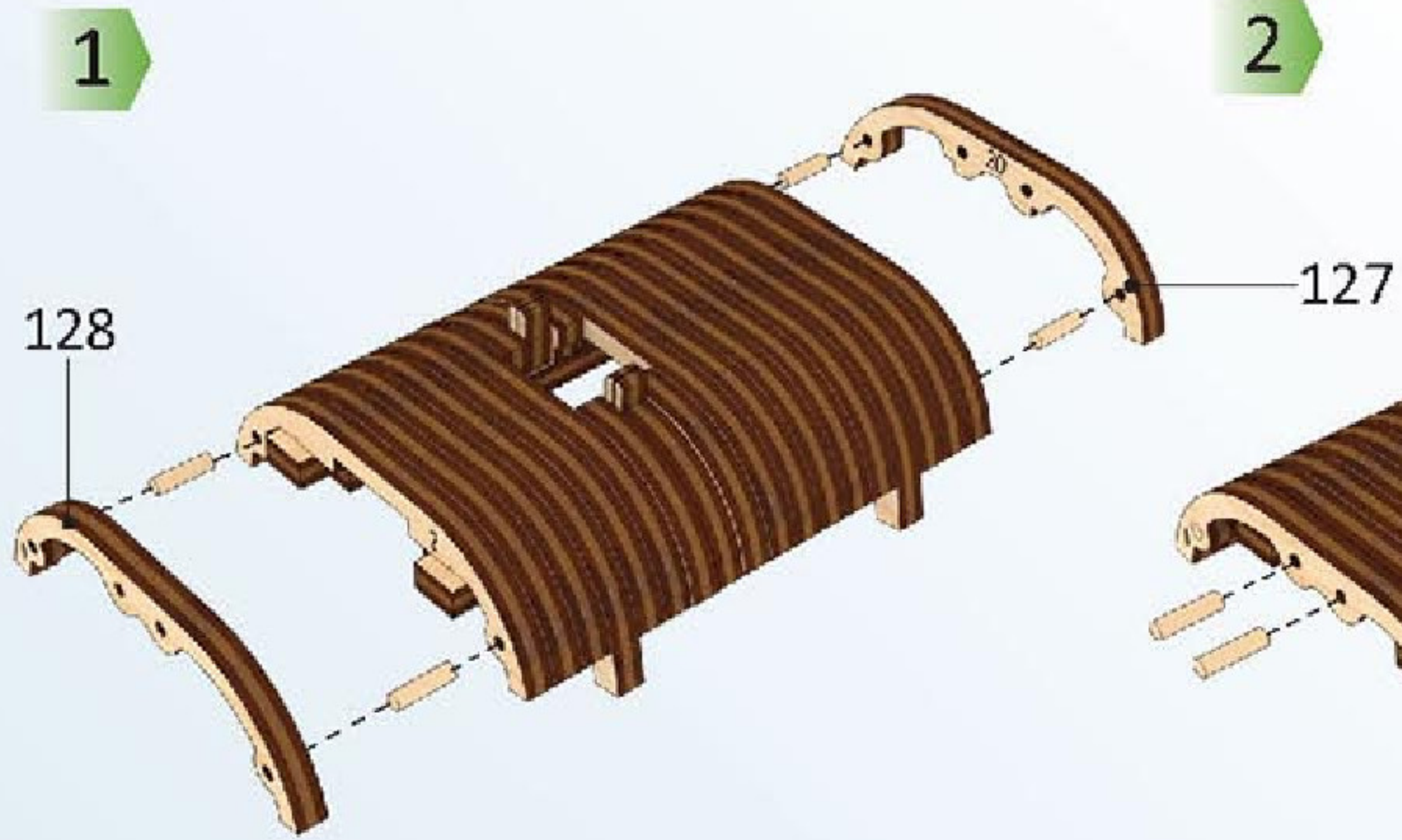
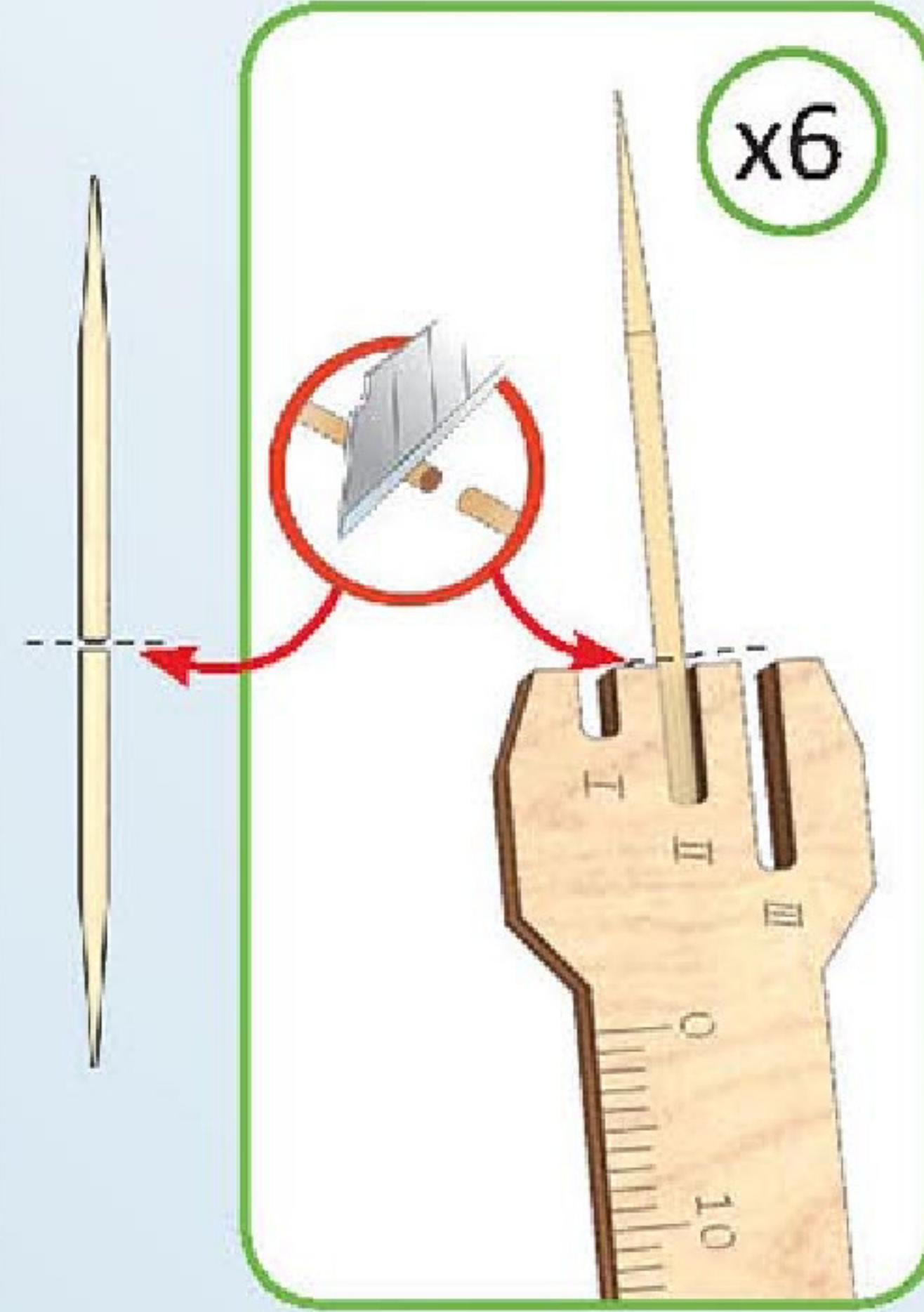

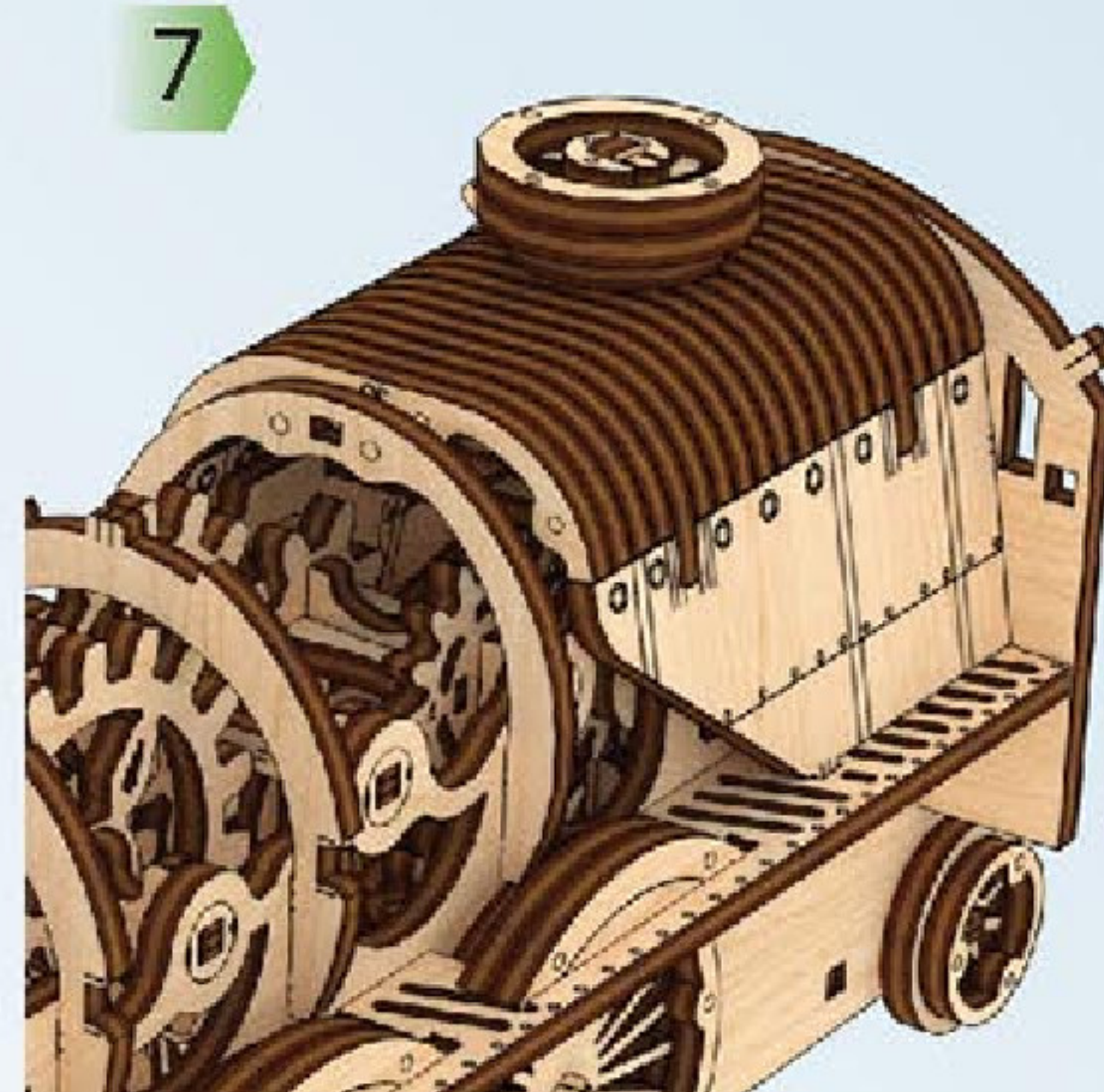
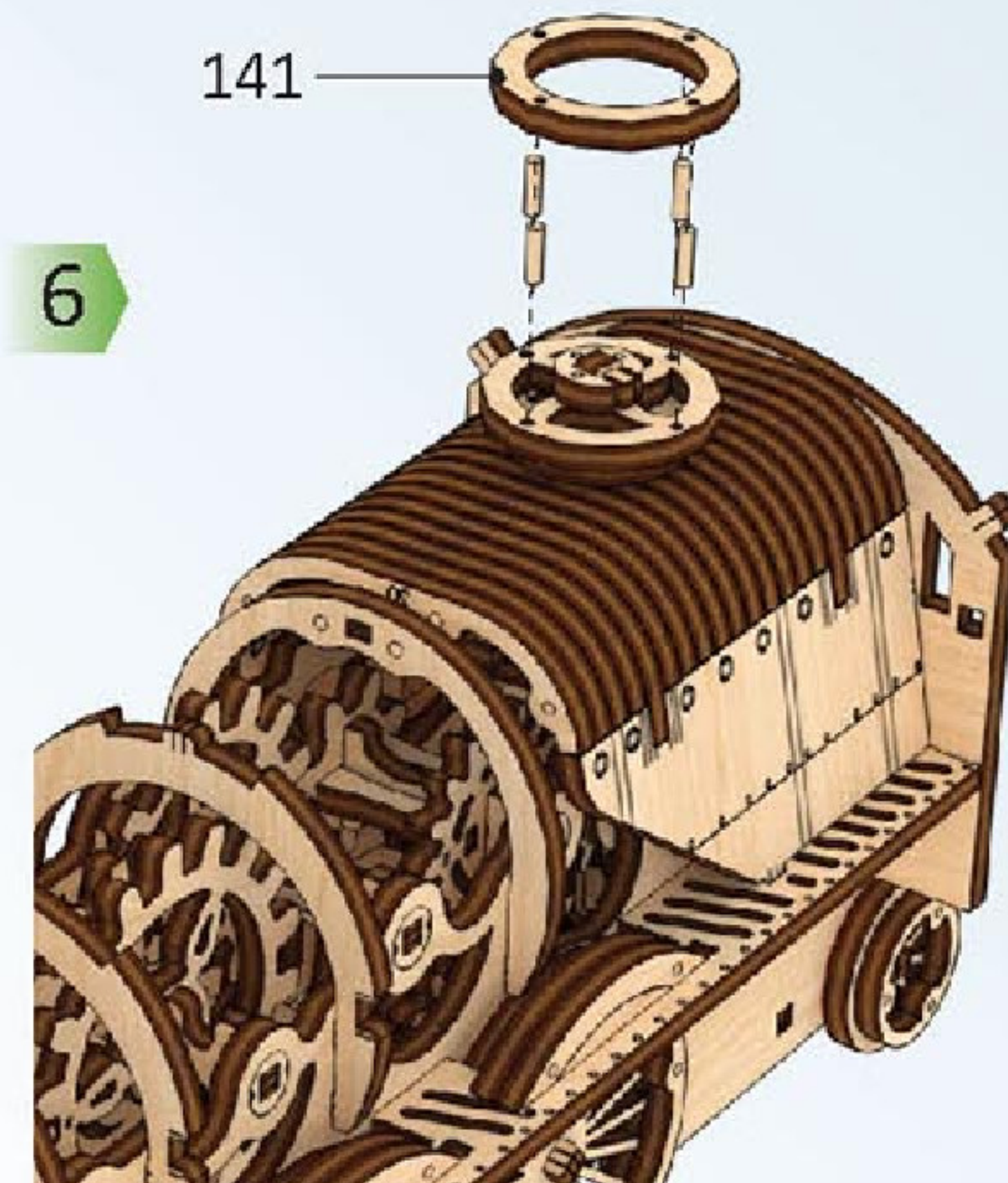
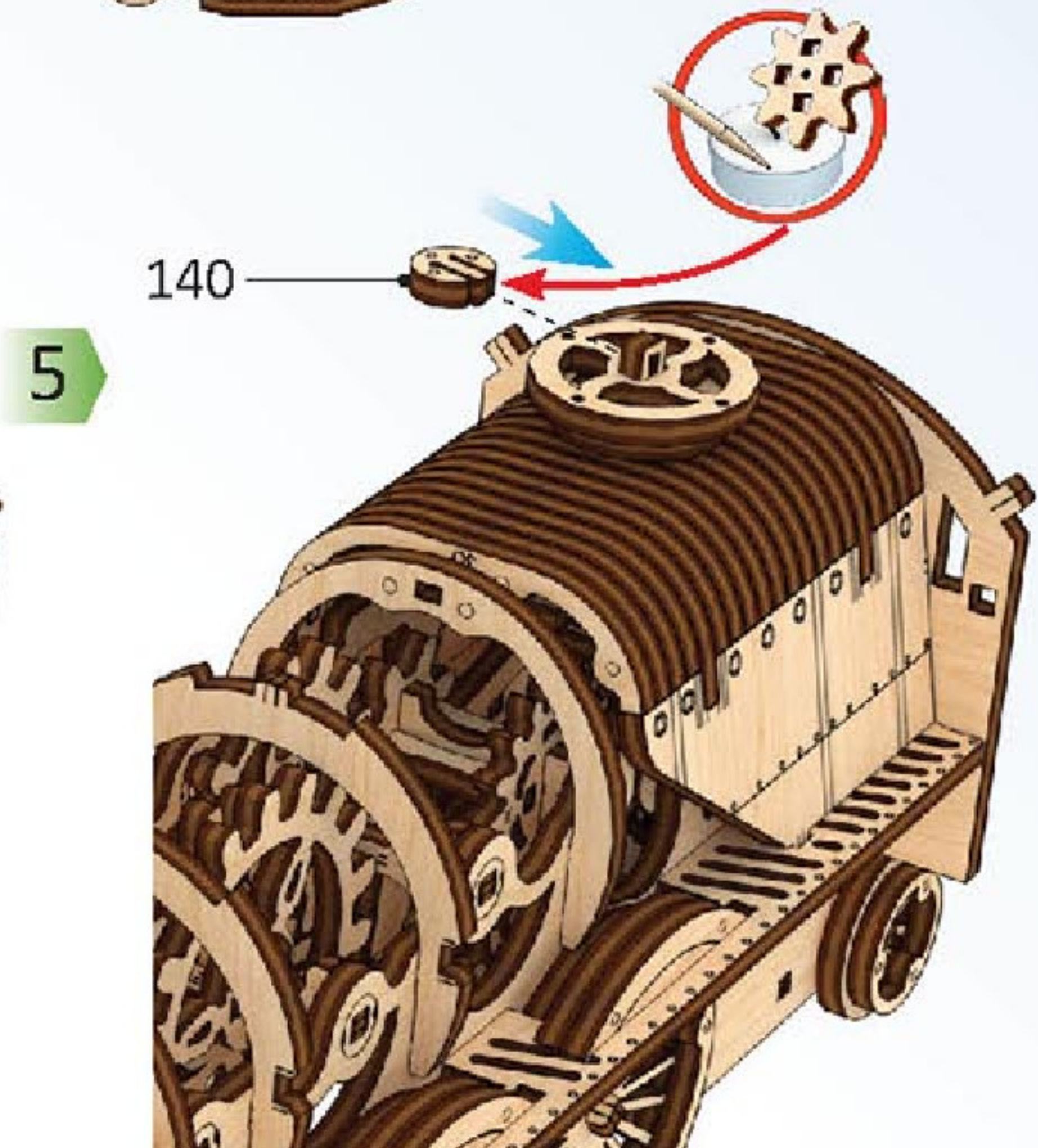
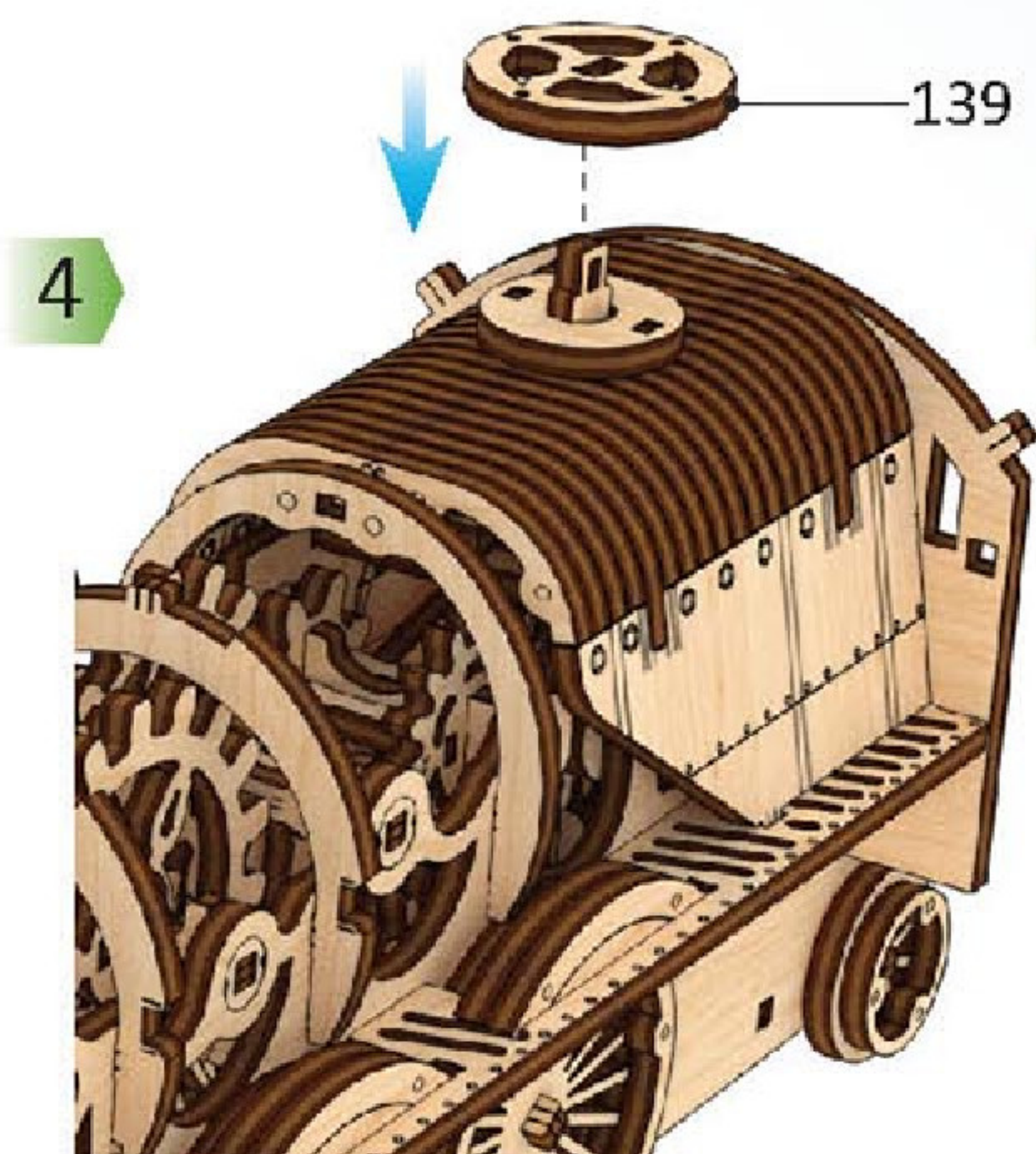
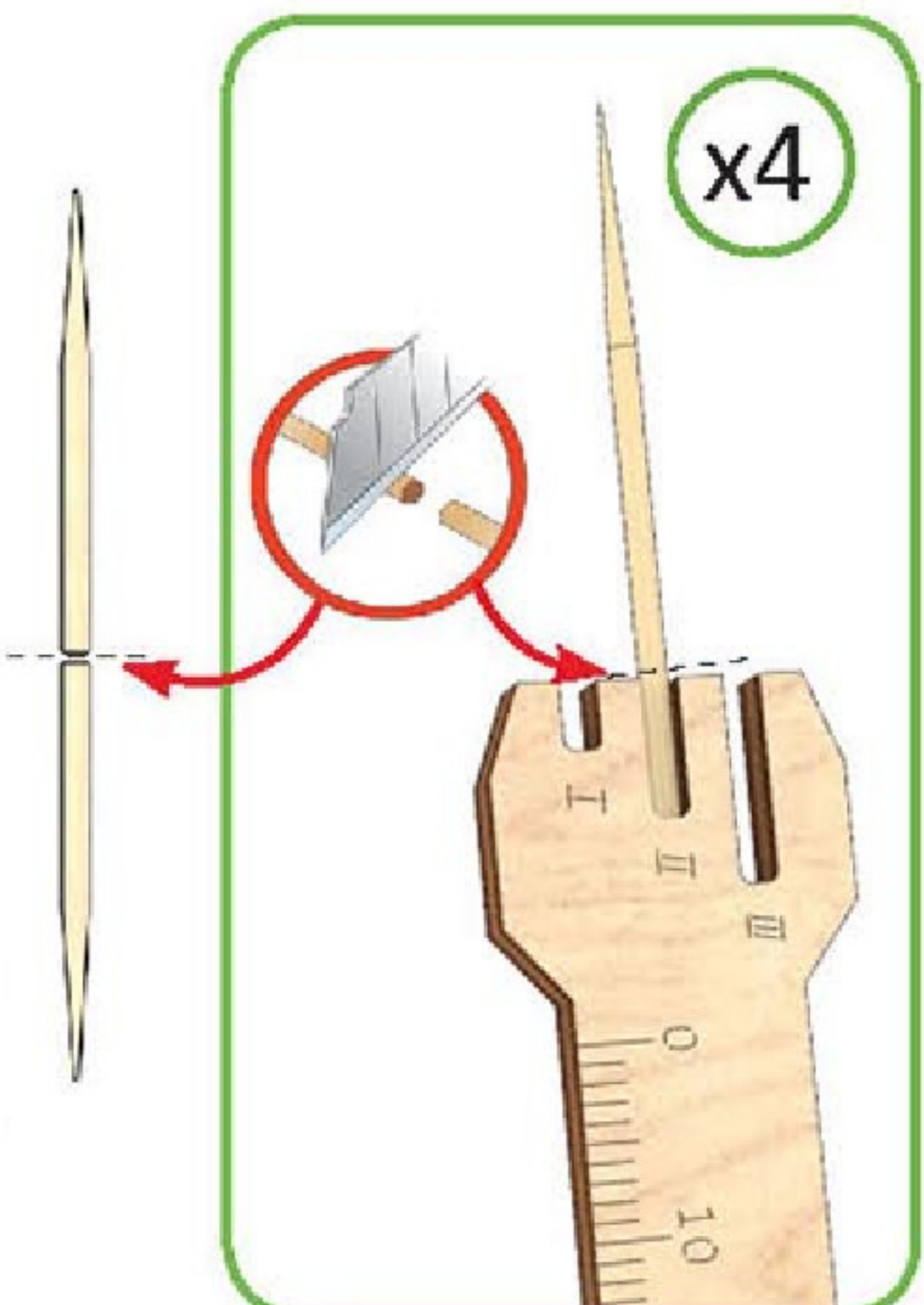
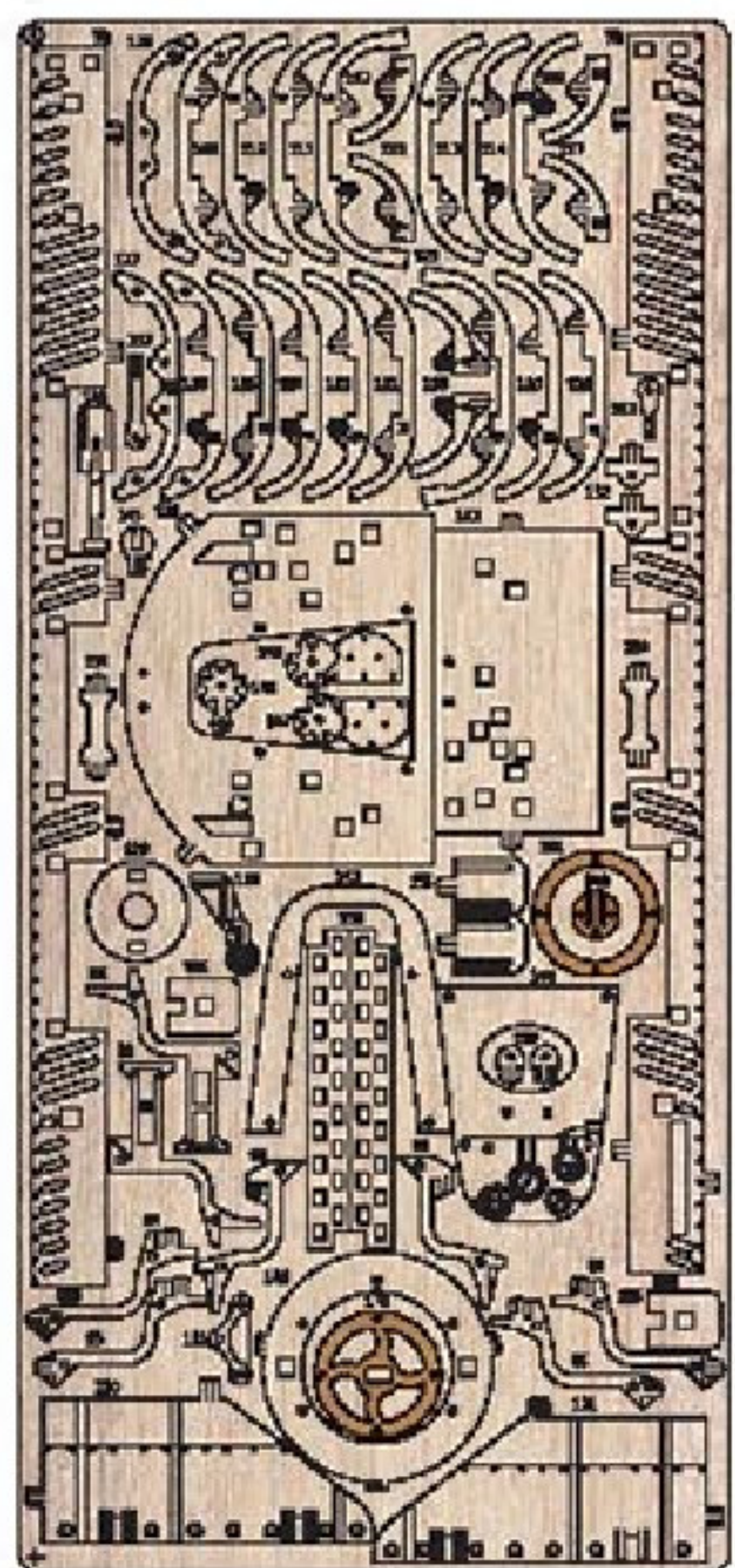
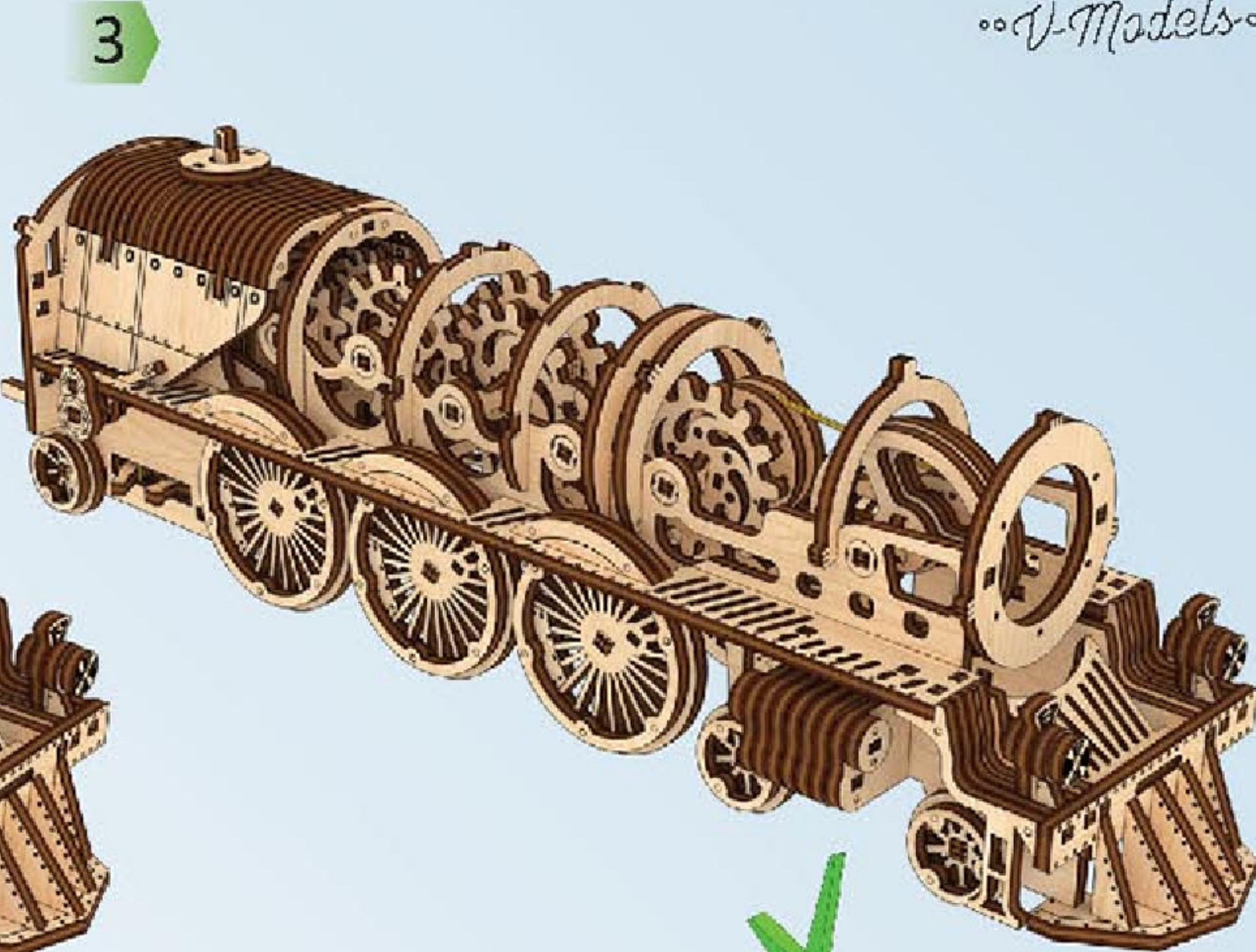
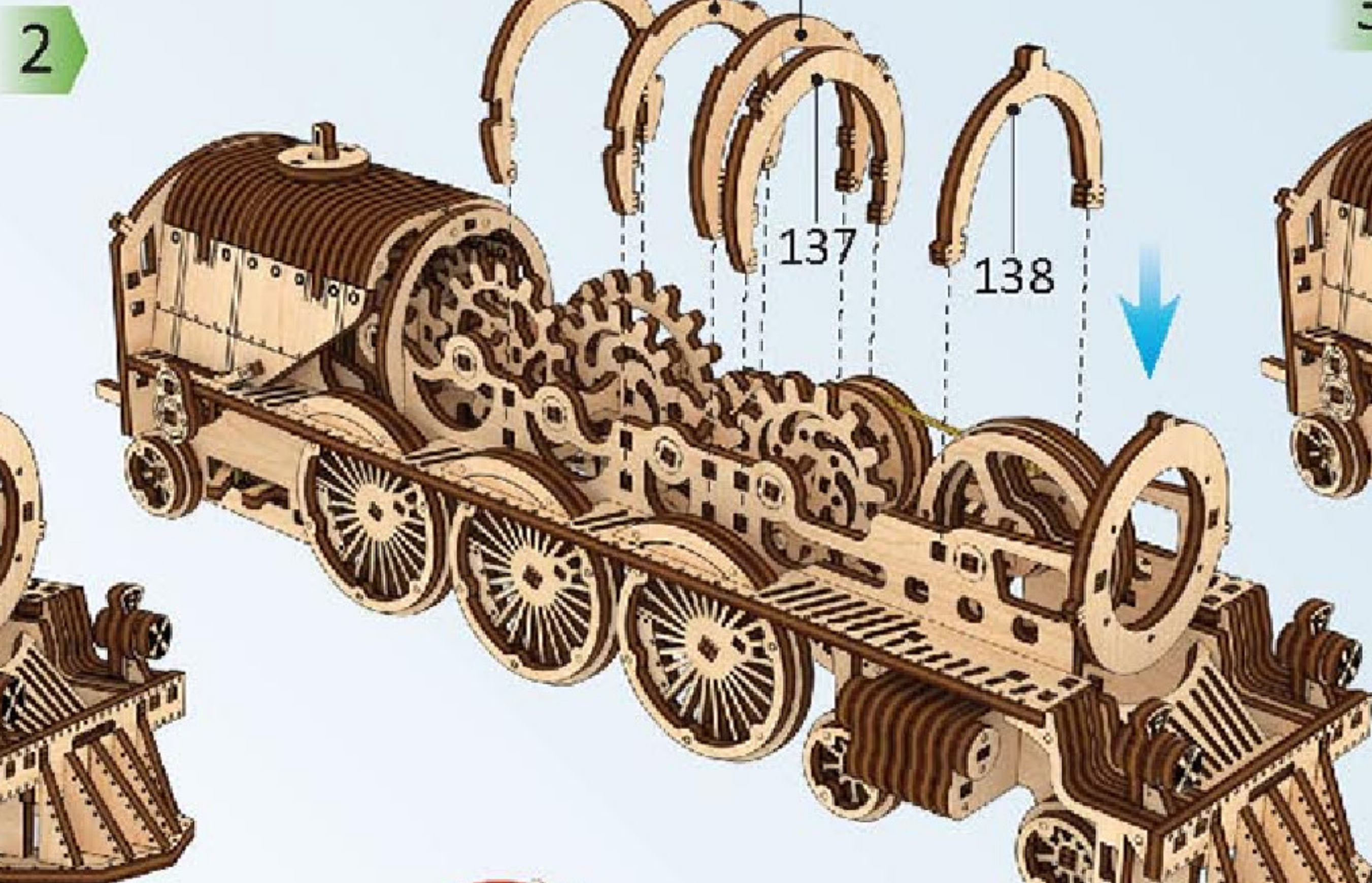
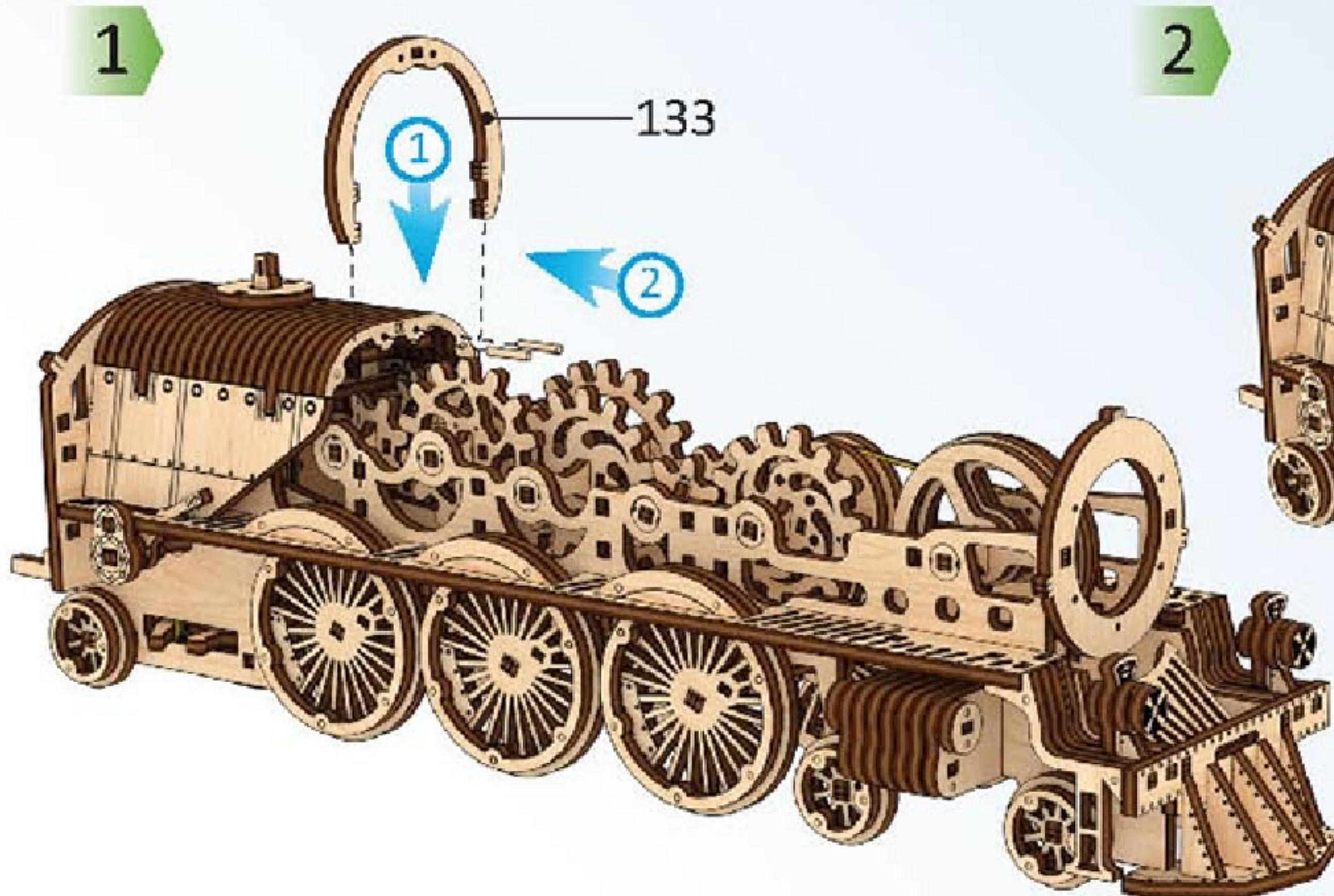
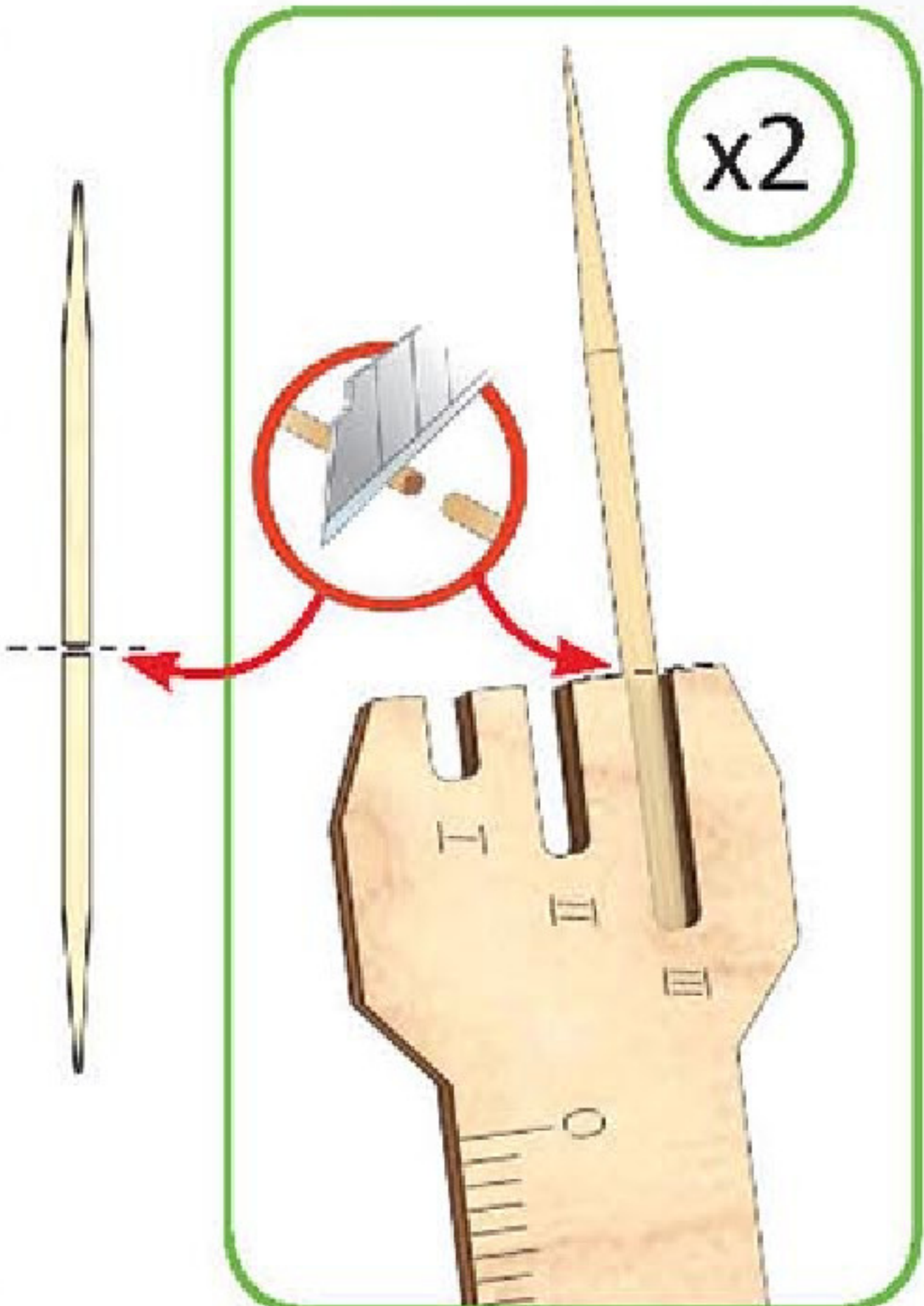
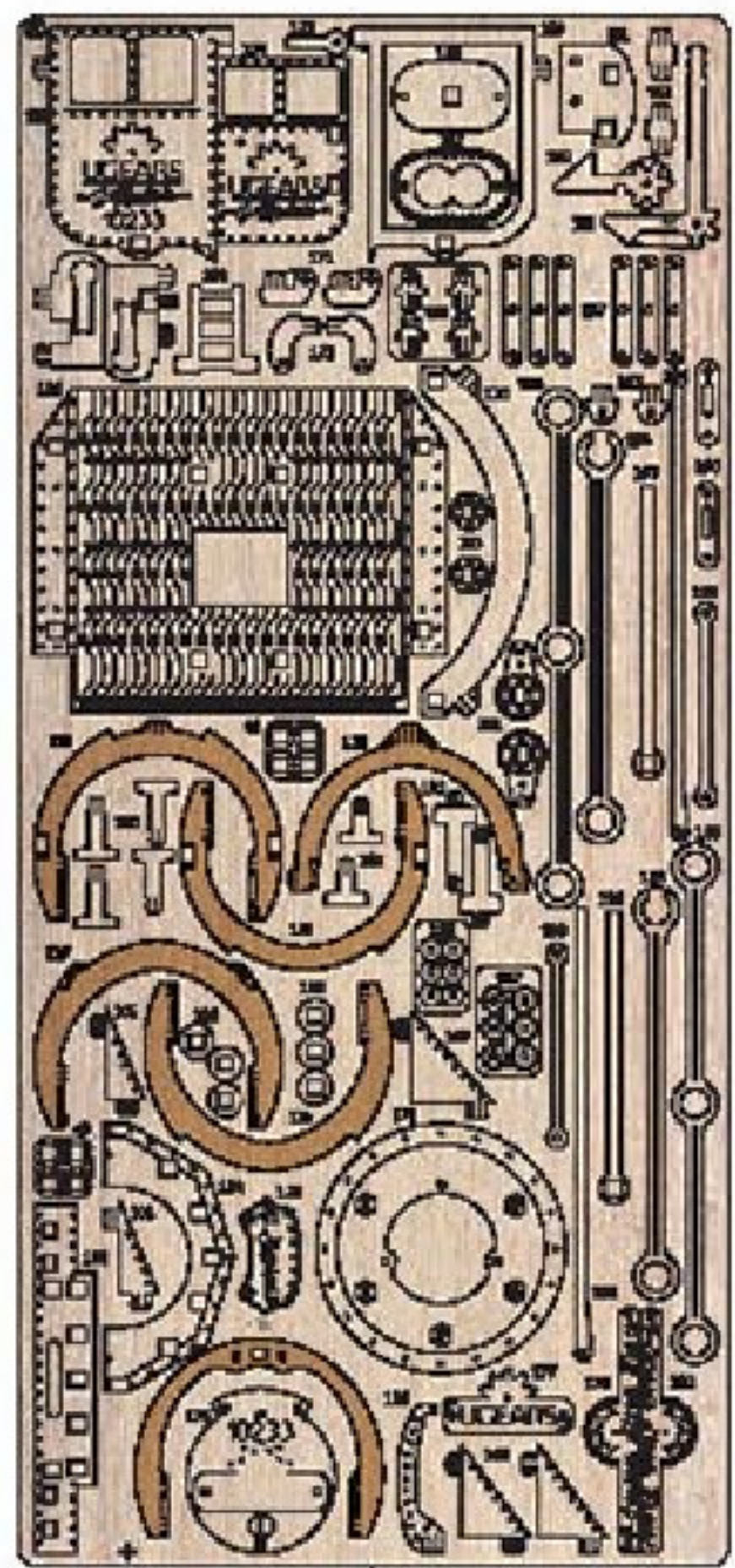

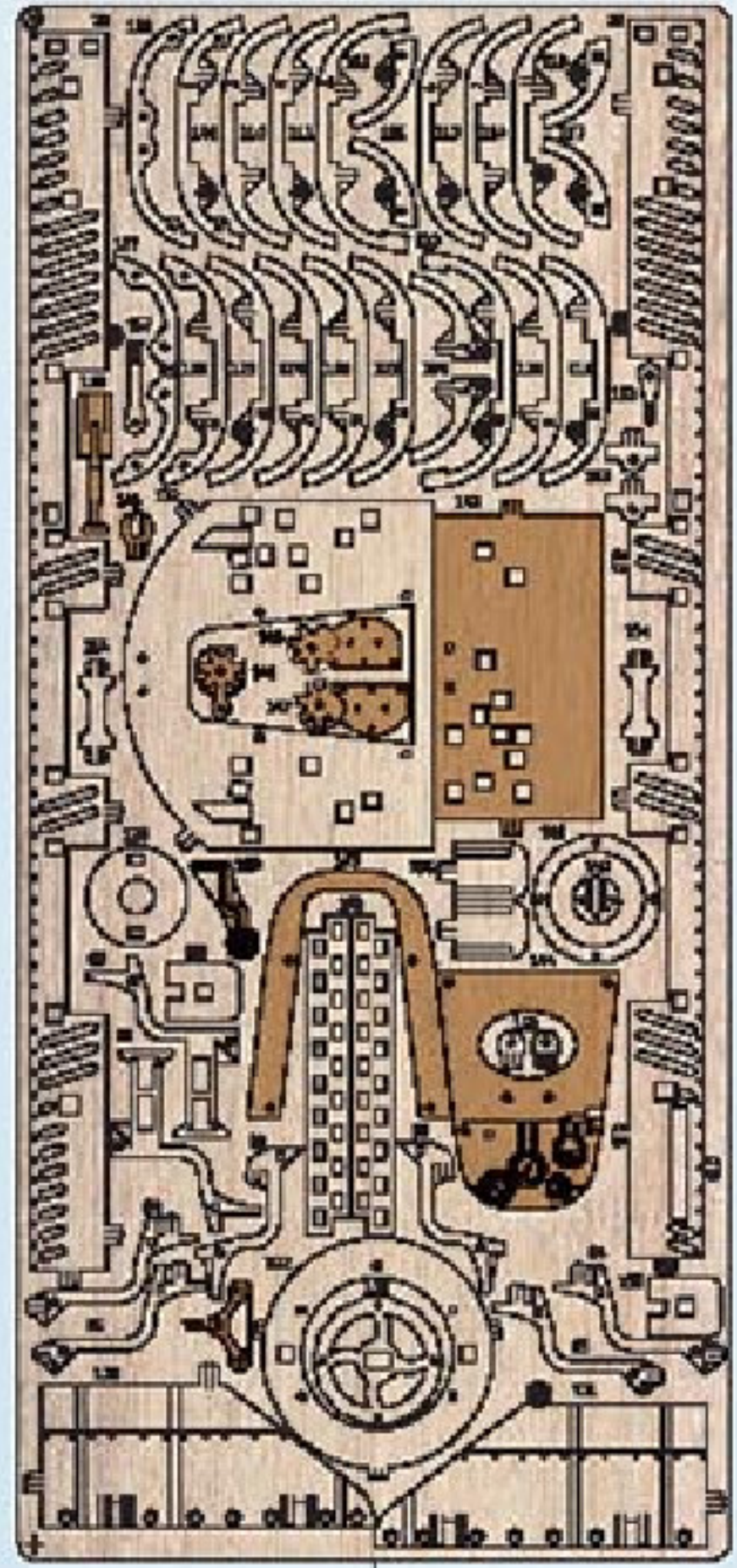

1

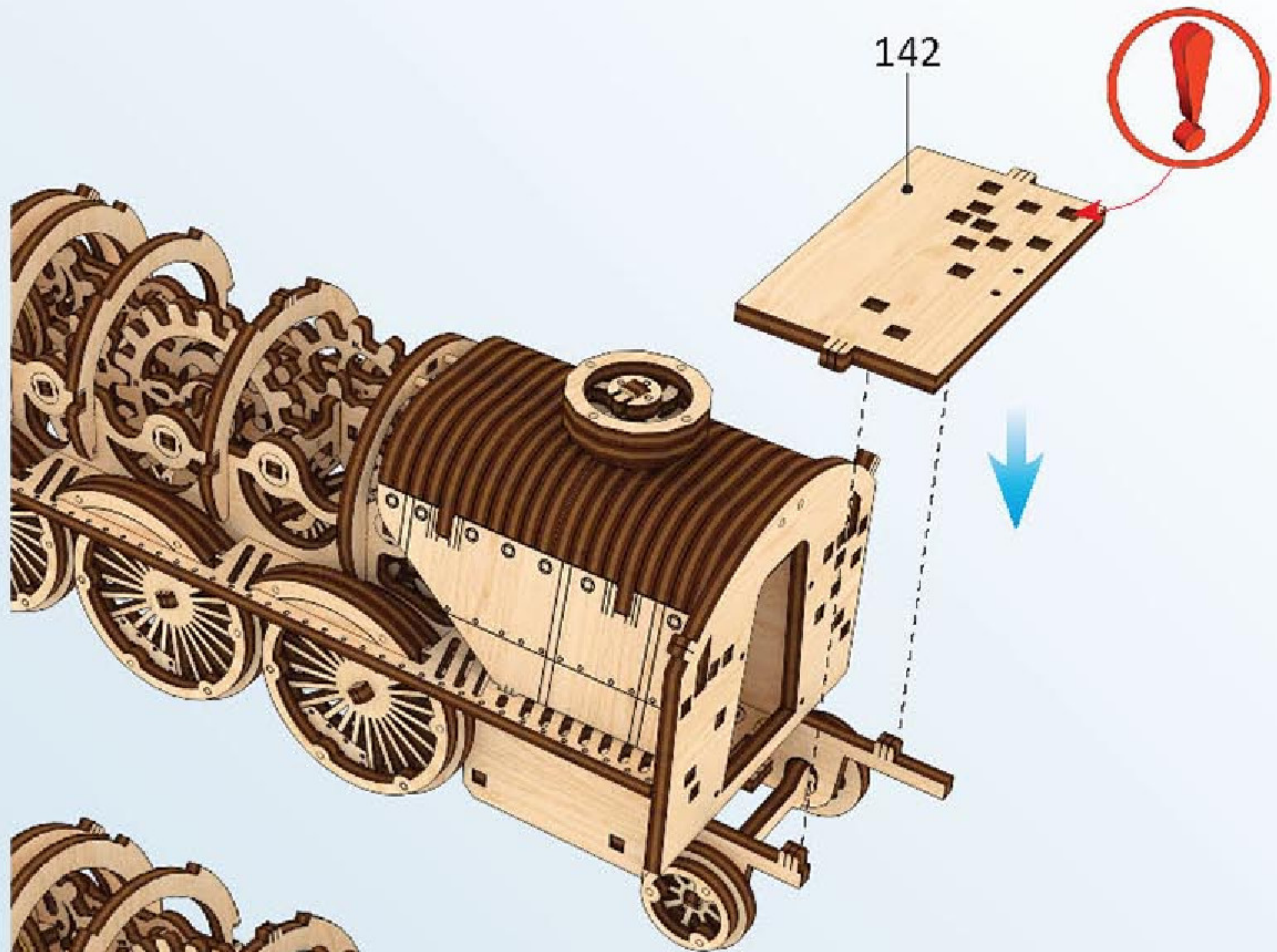

3

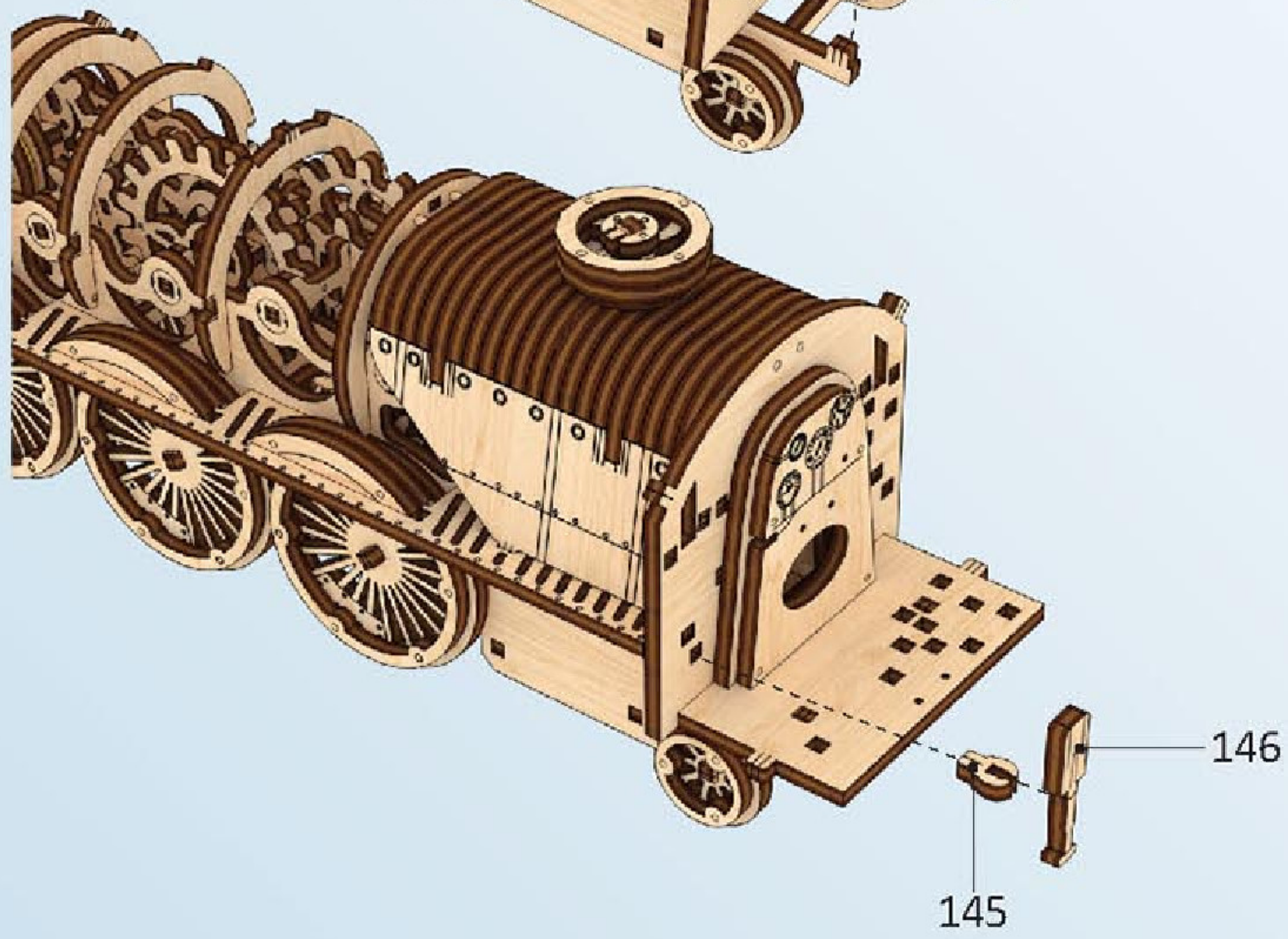

2

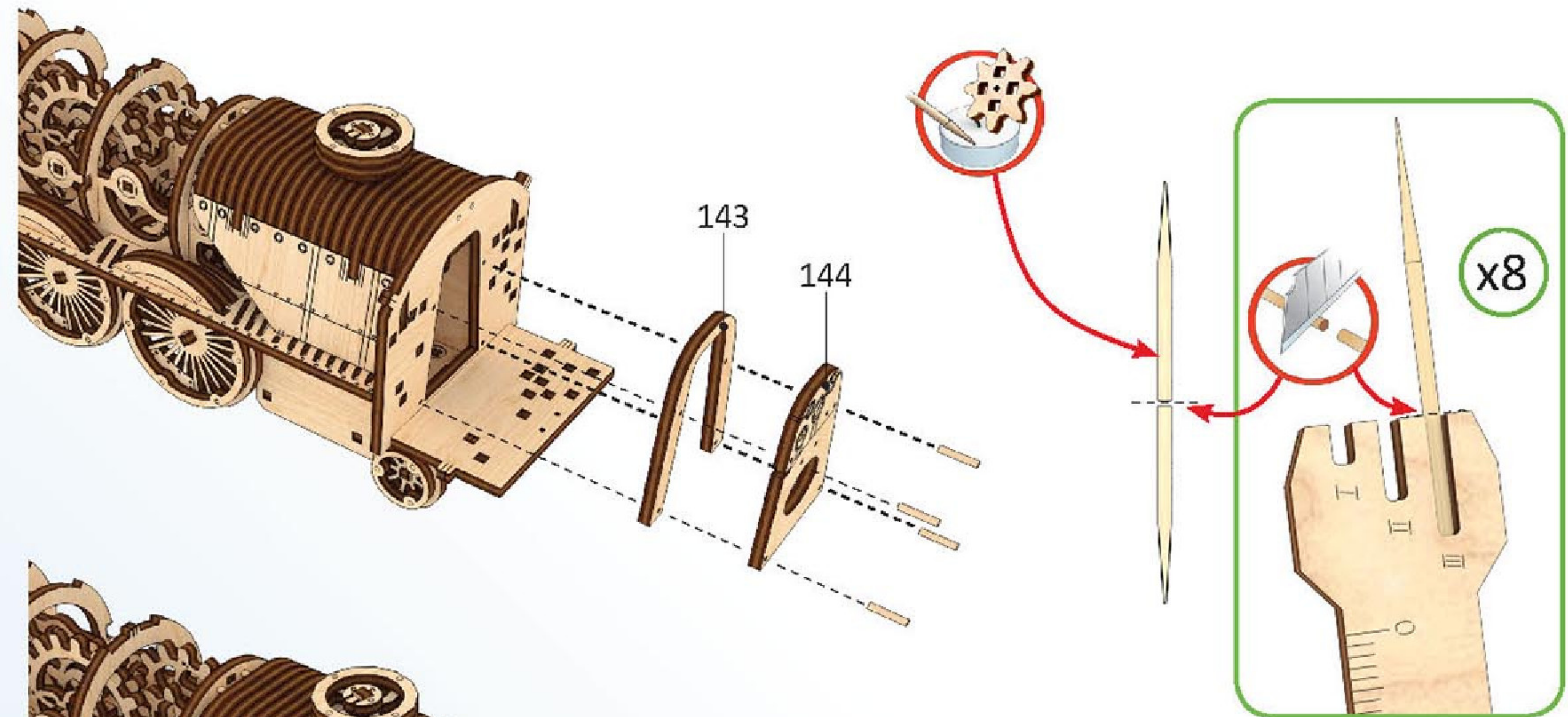

4

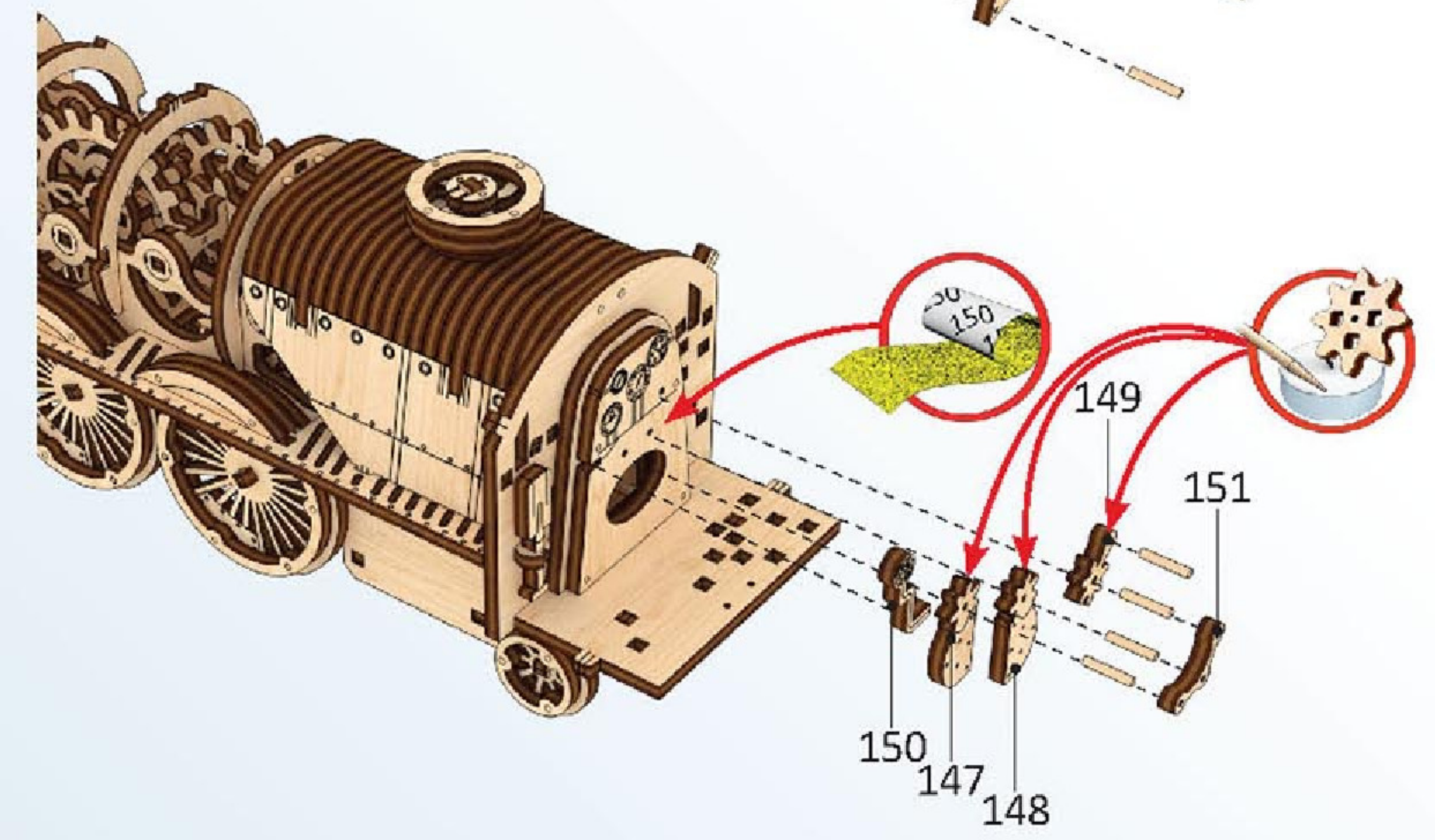



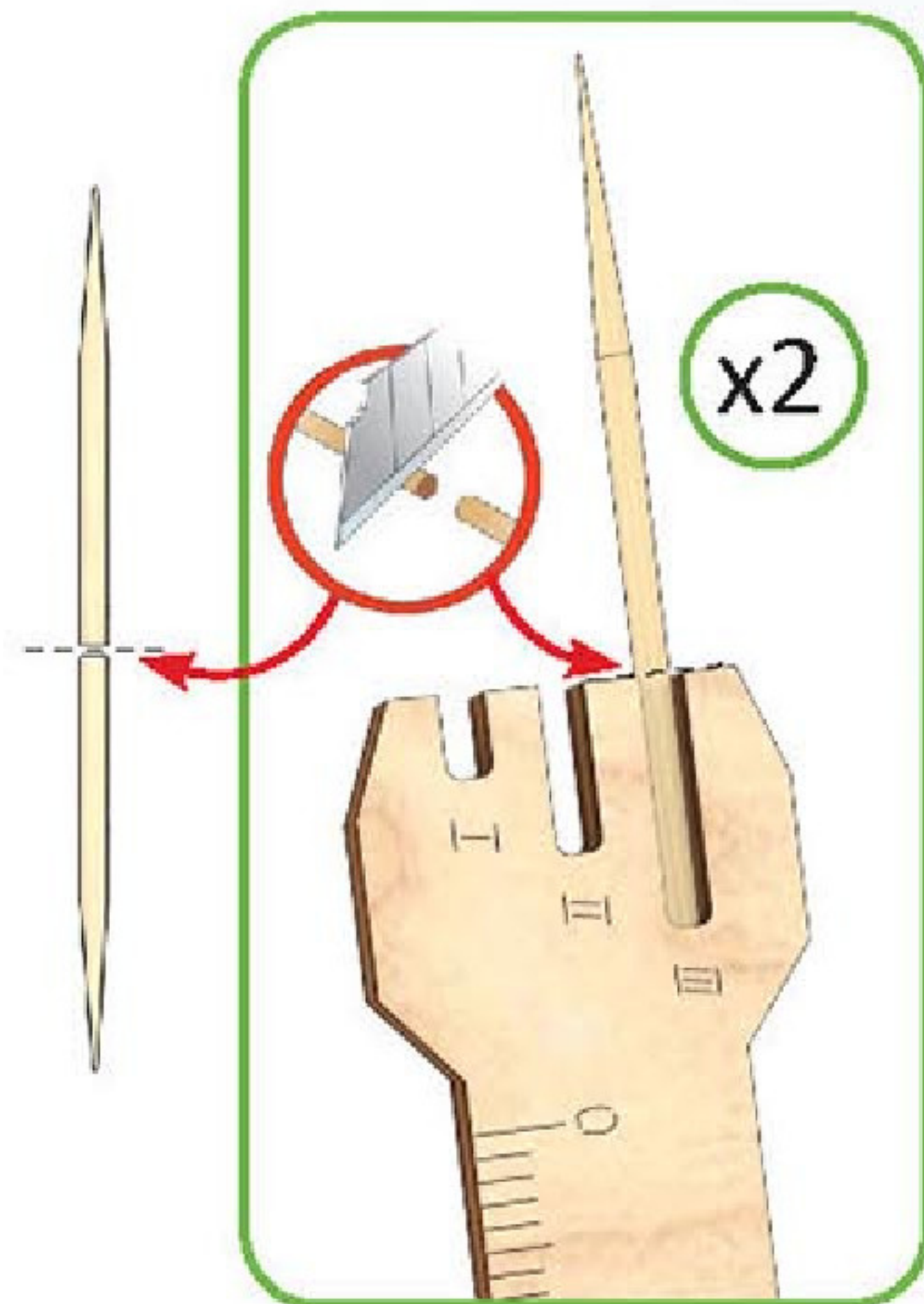
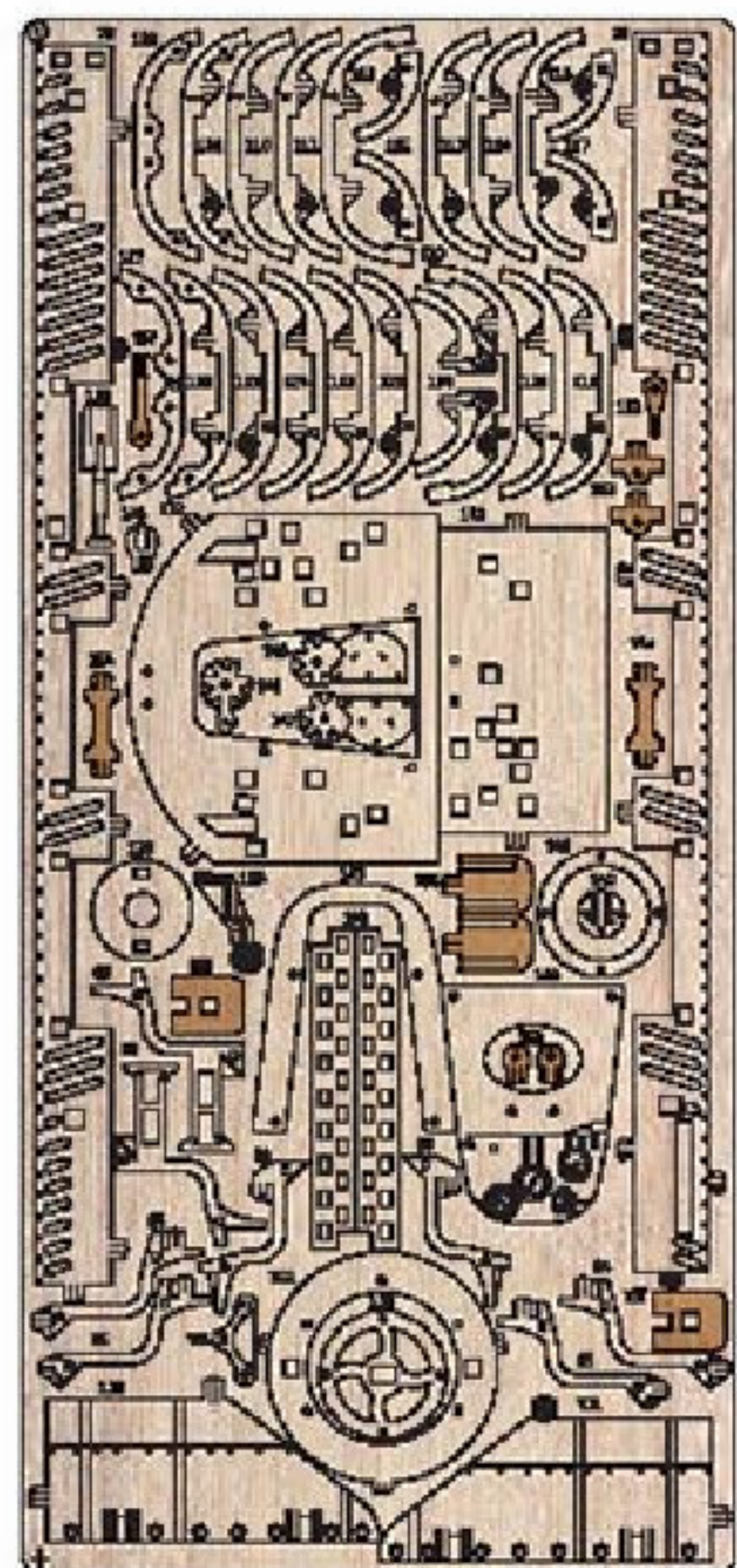

1

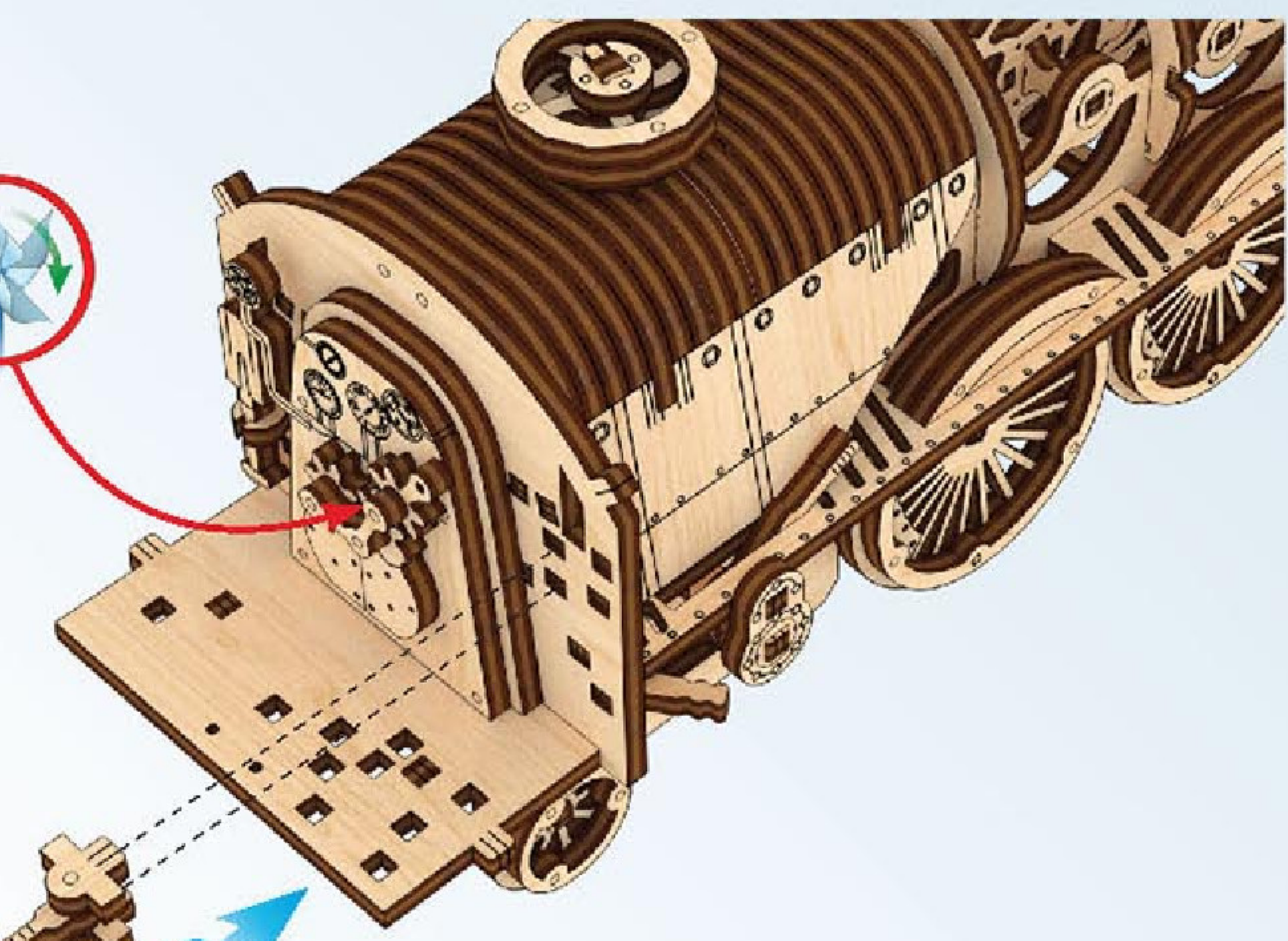
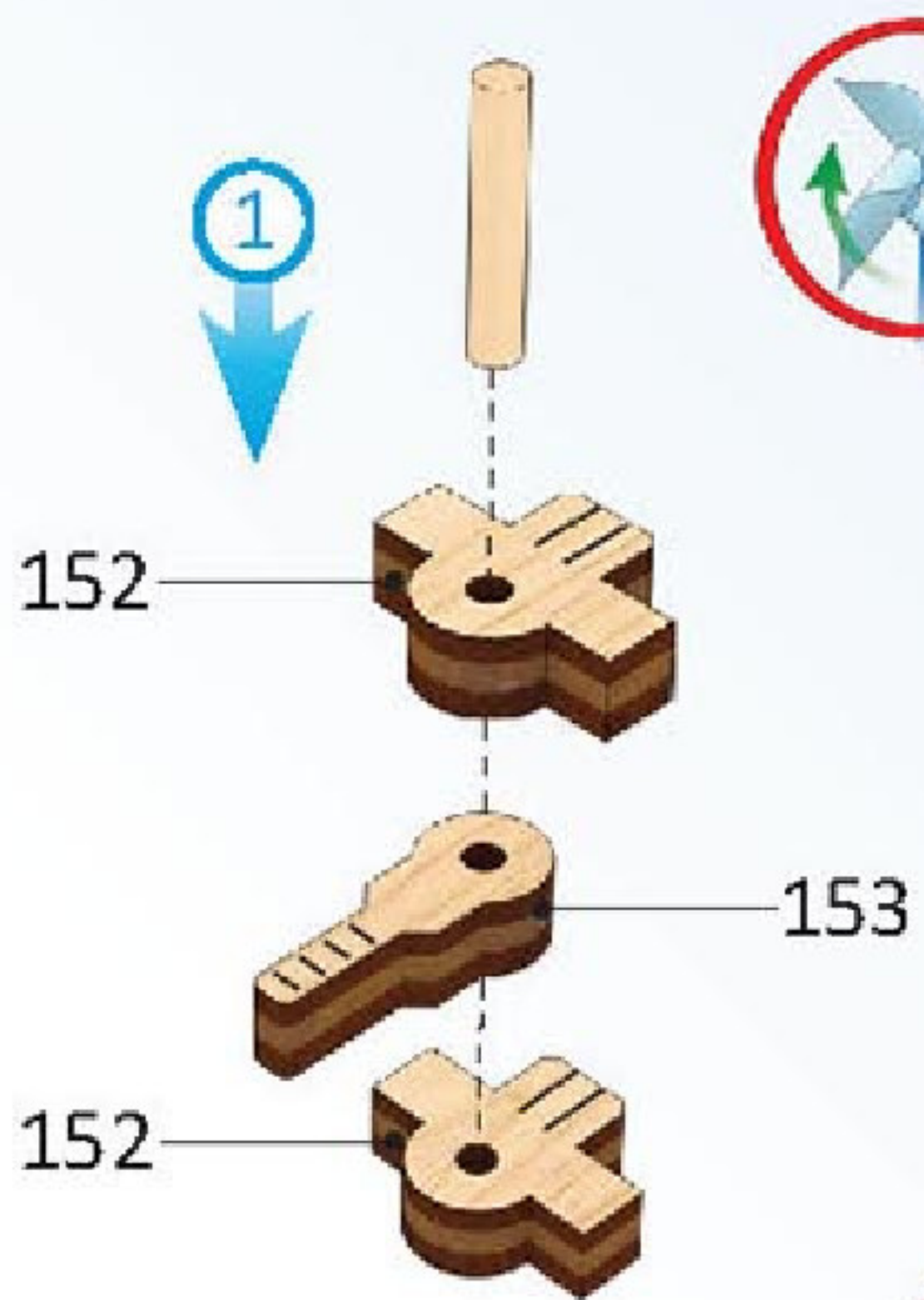

2

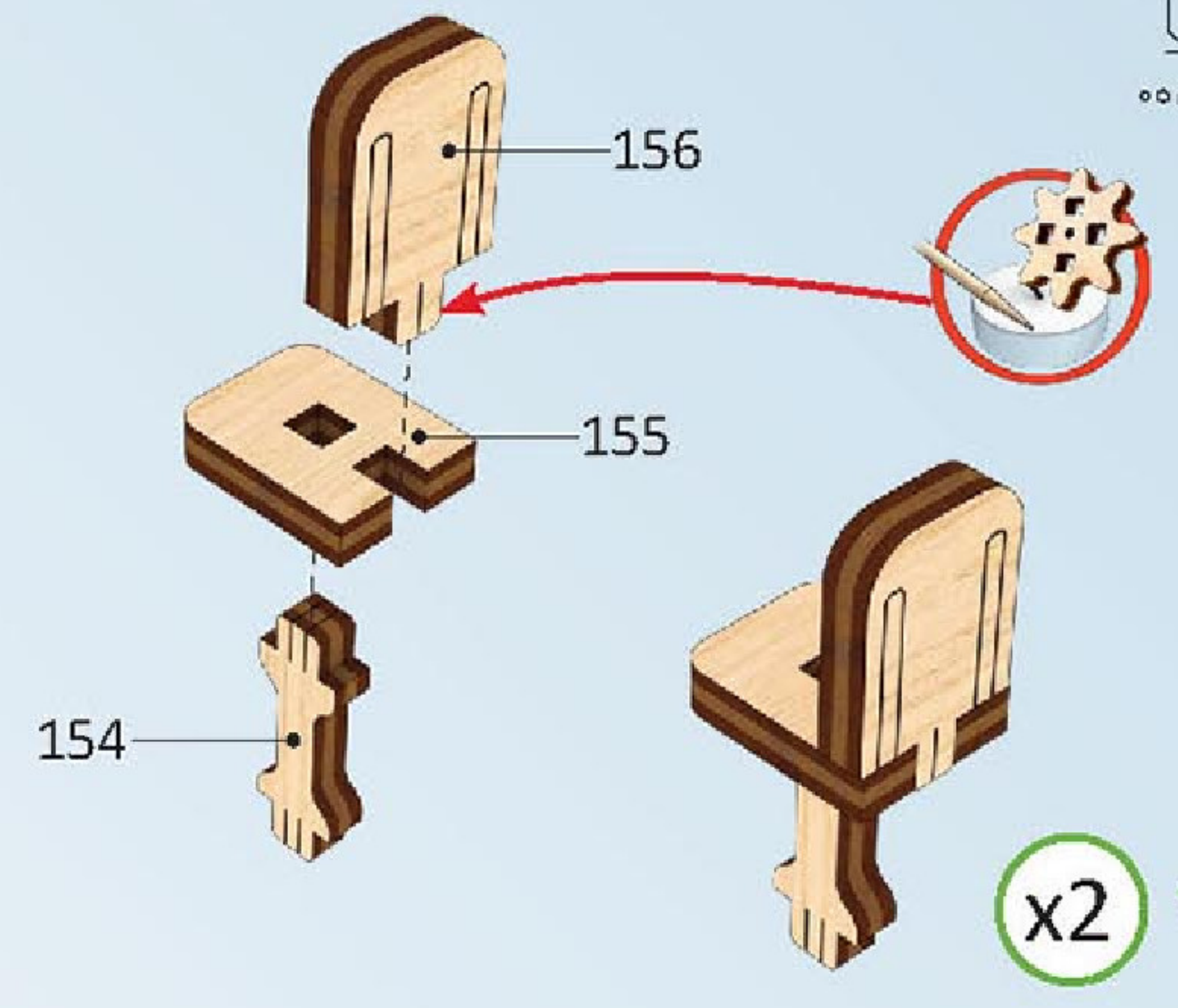

3

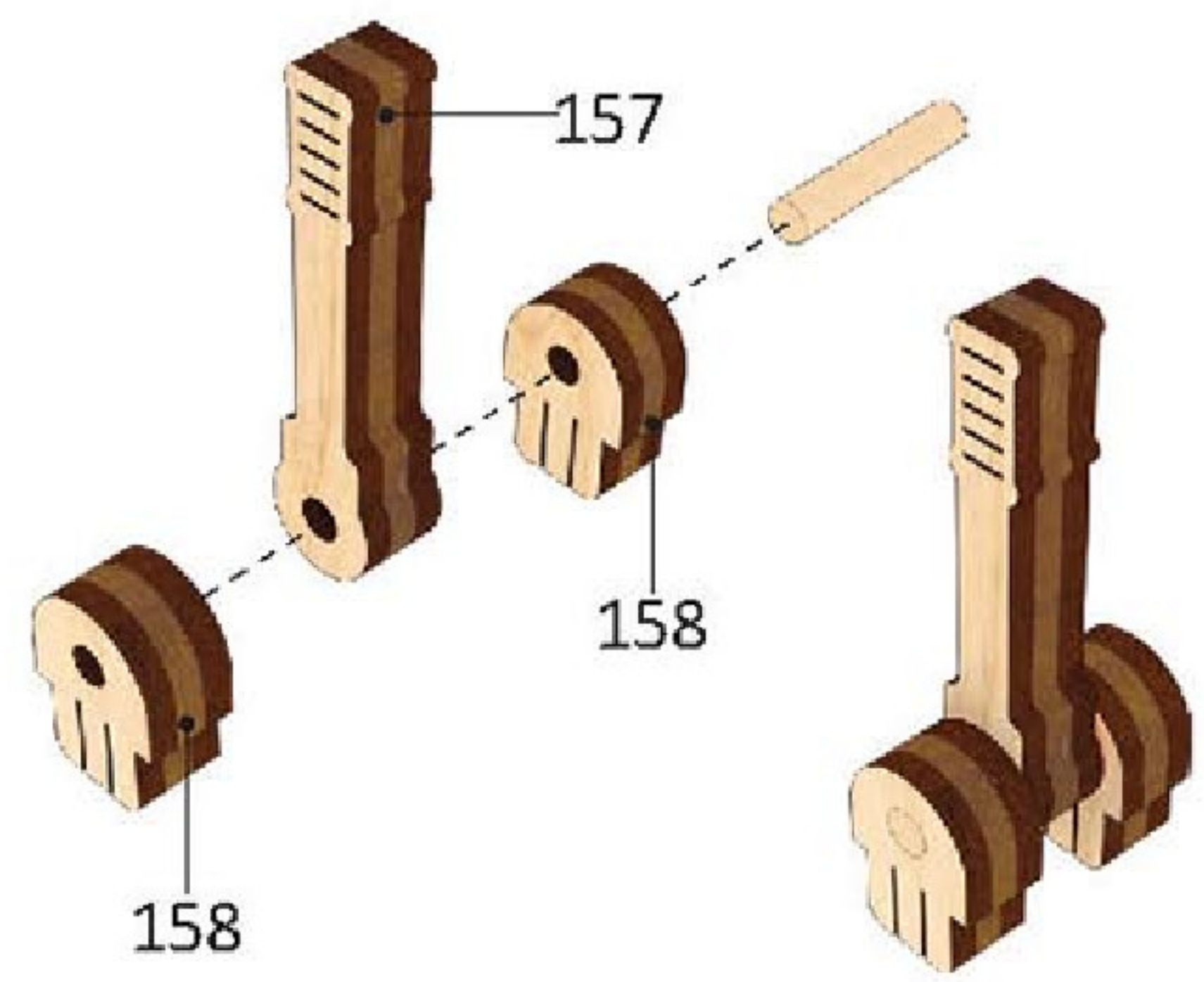

4

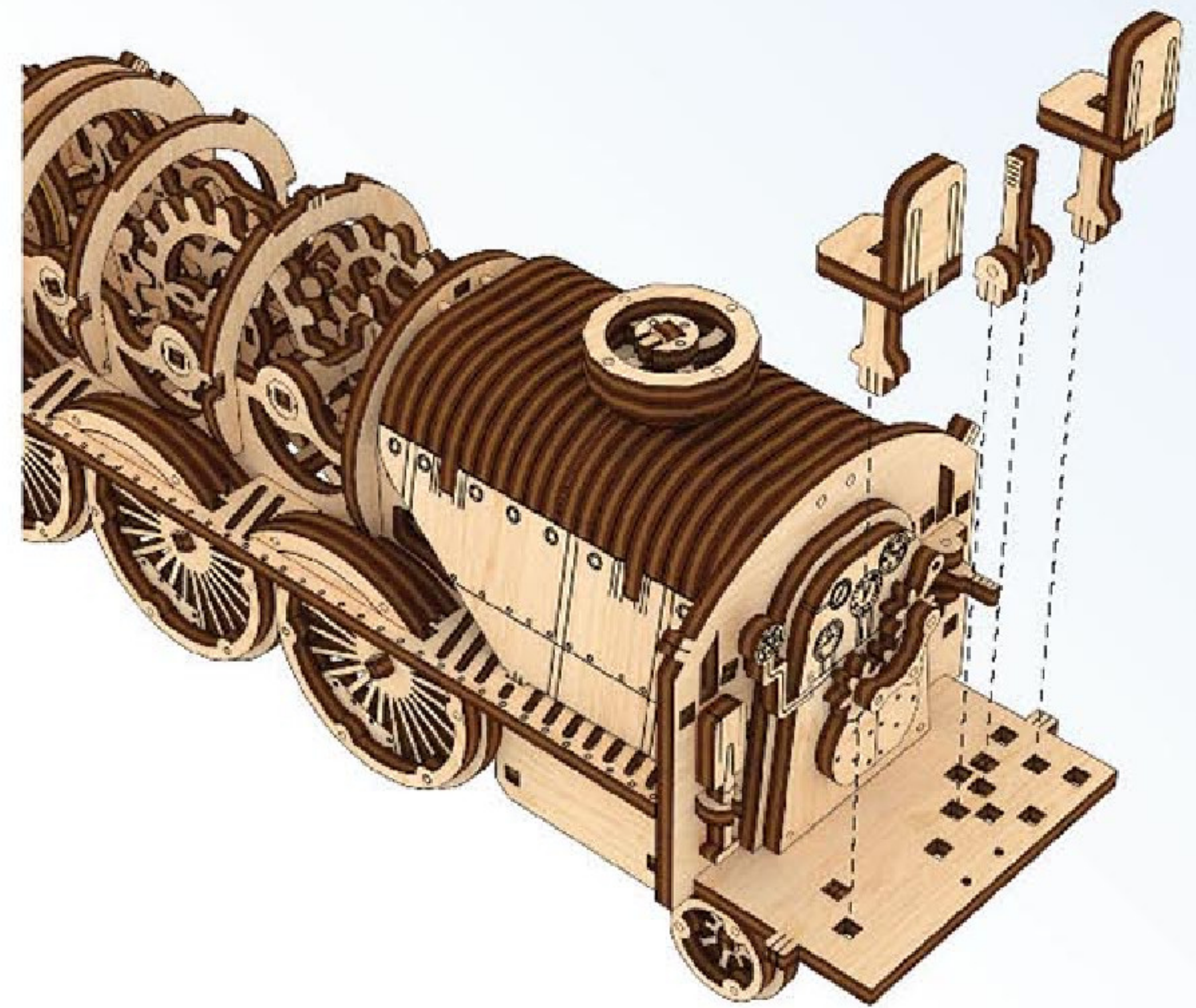

5

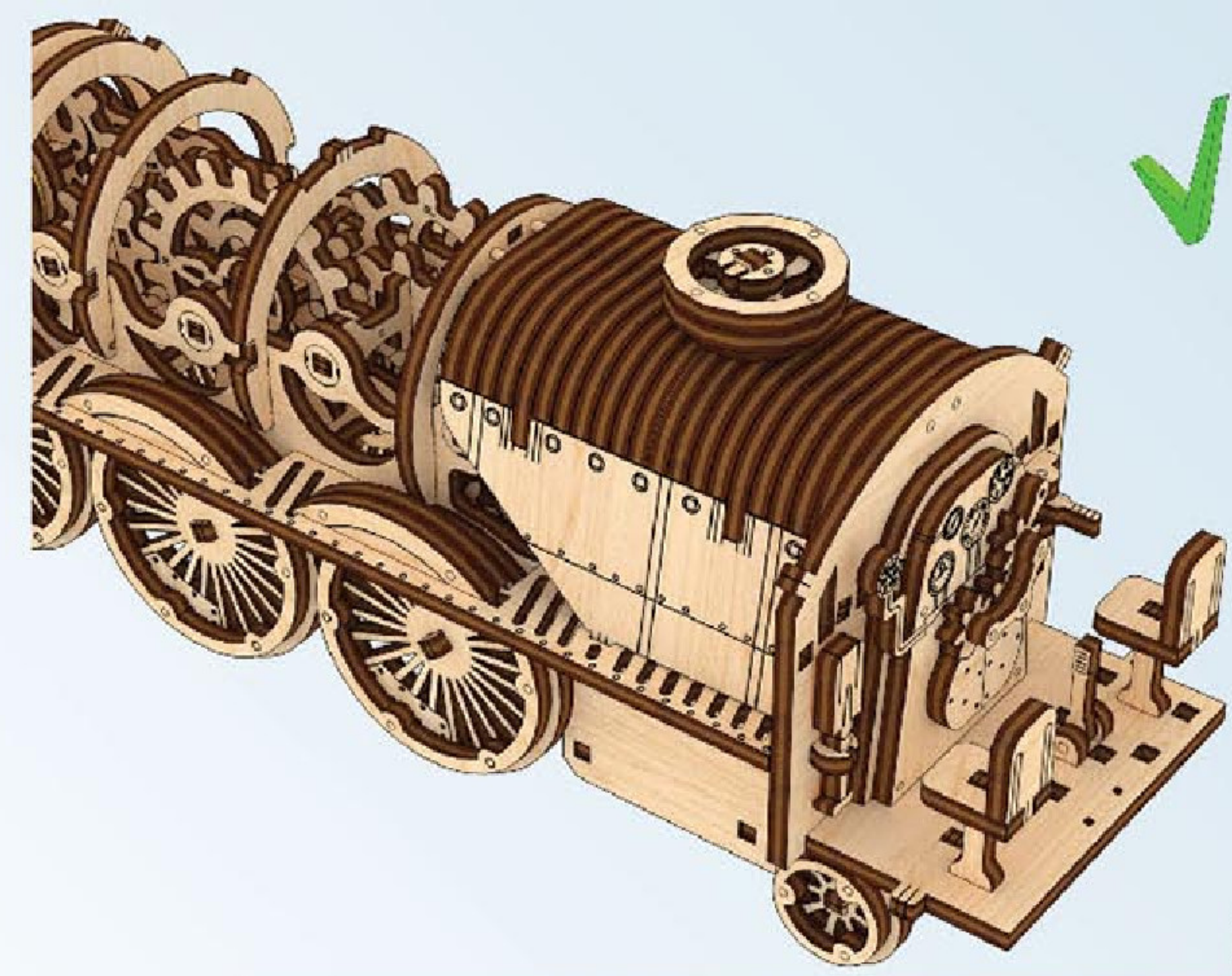

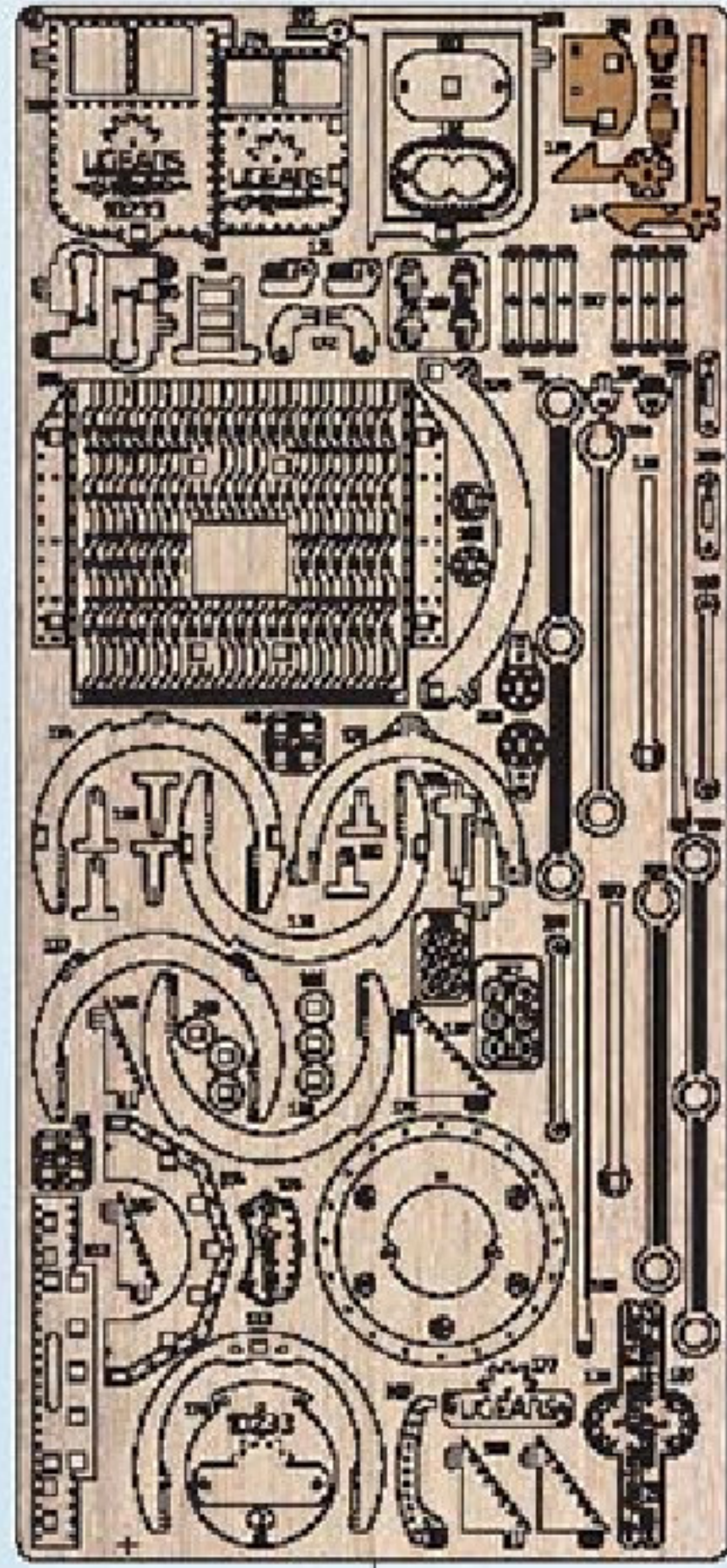

5

1

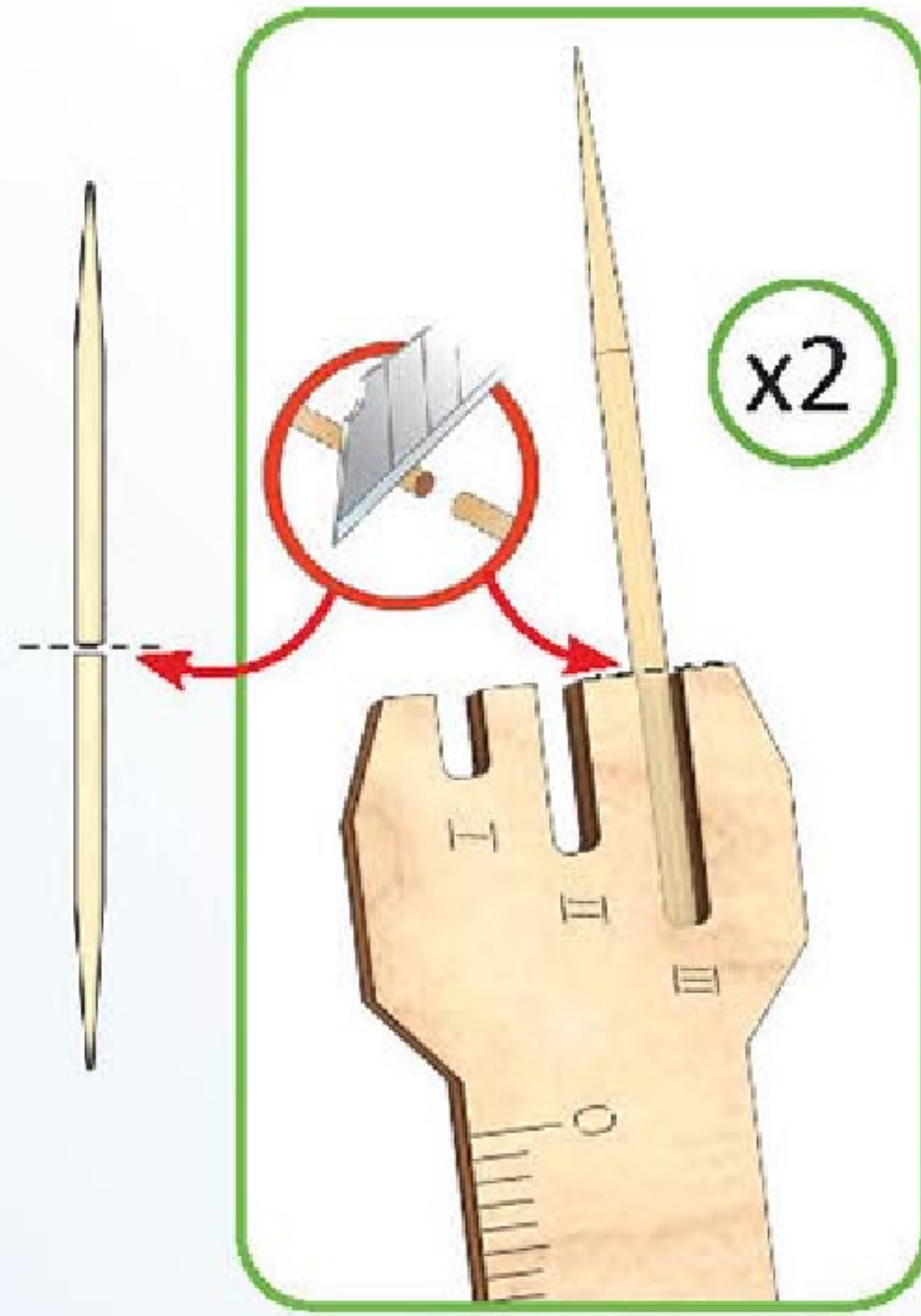
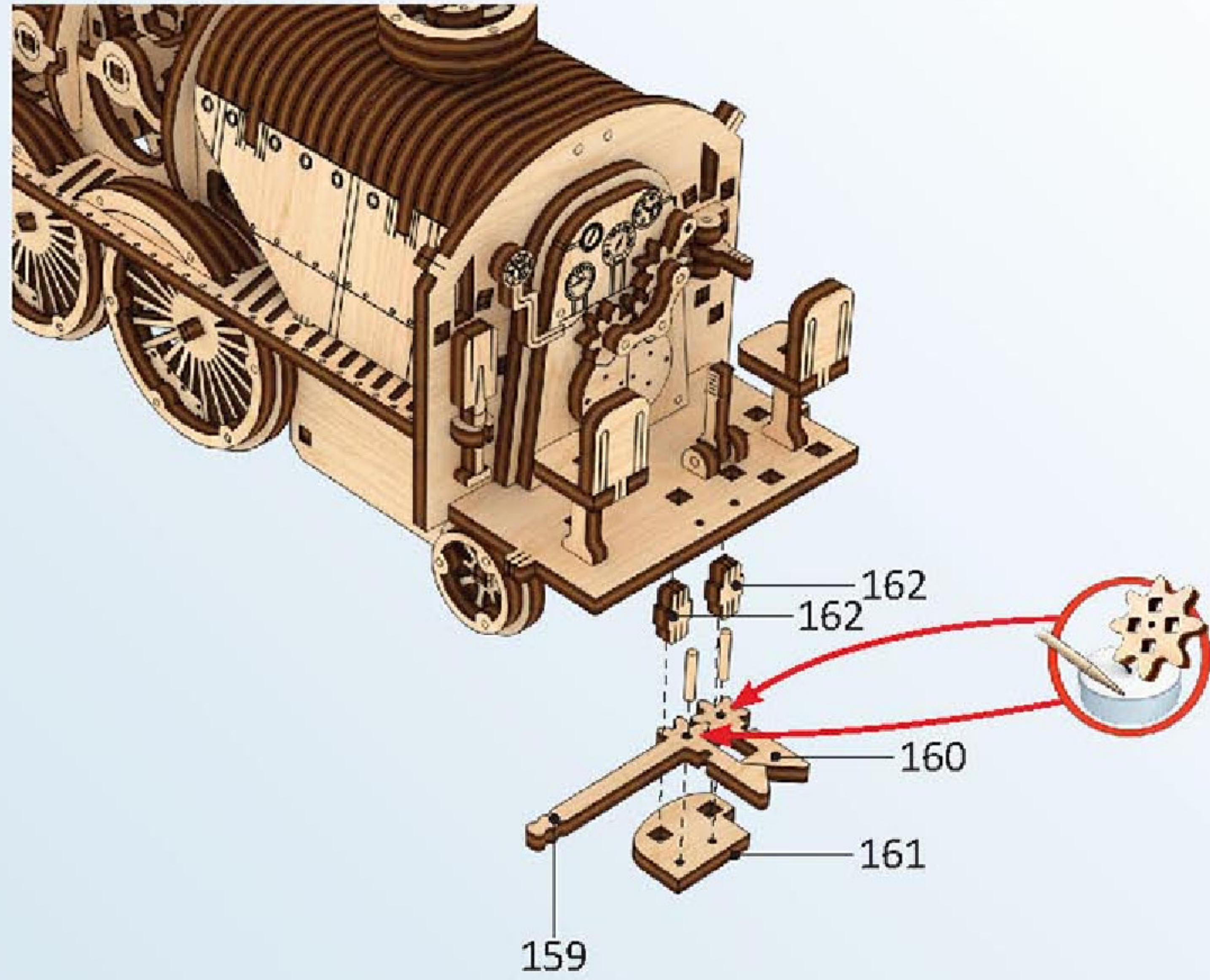

2

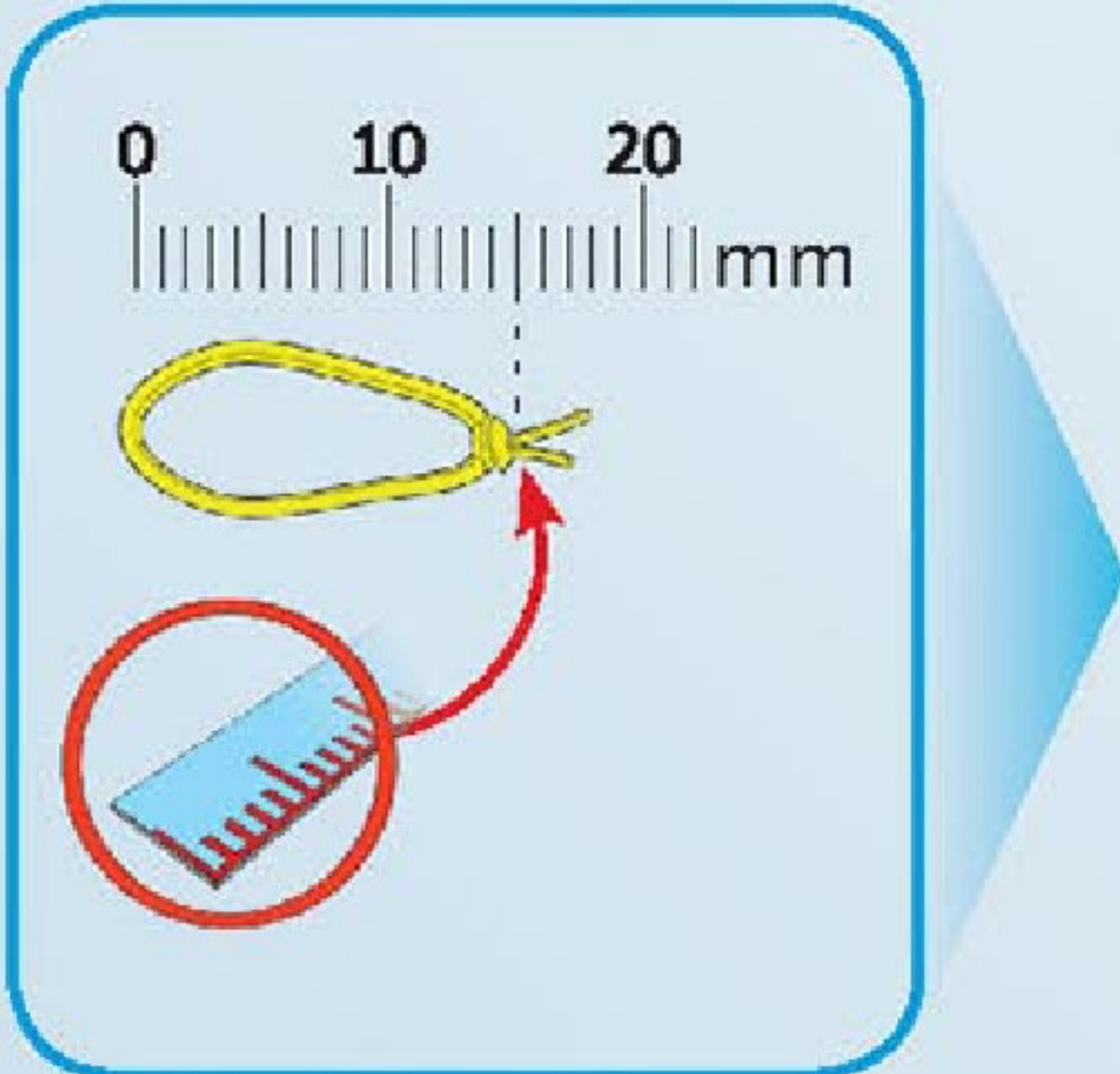
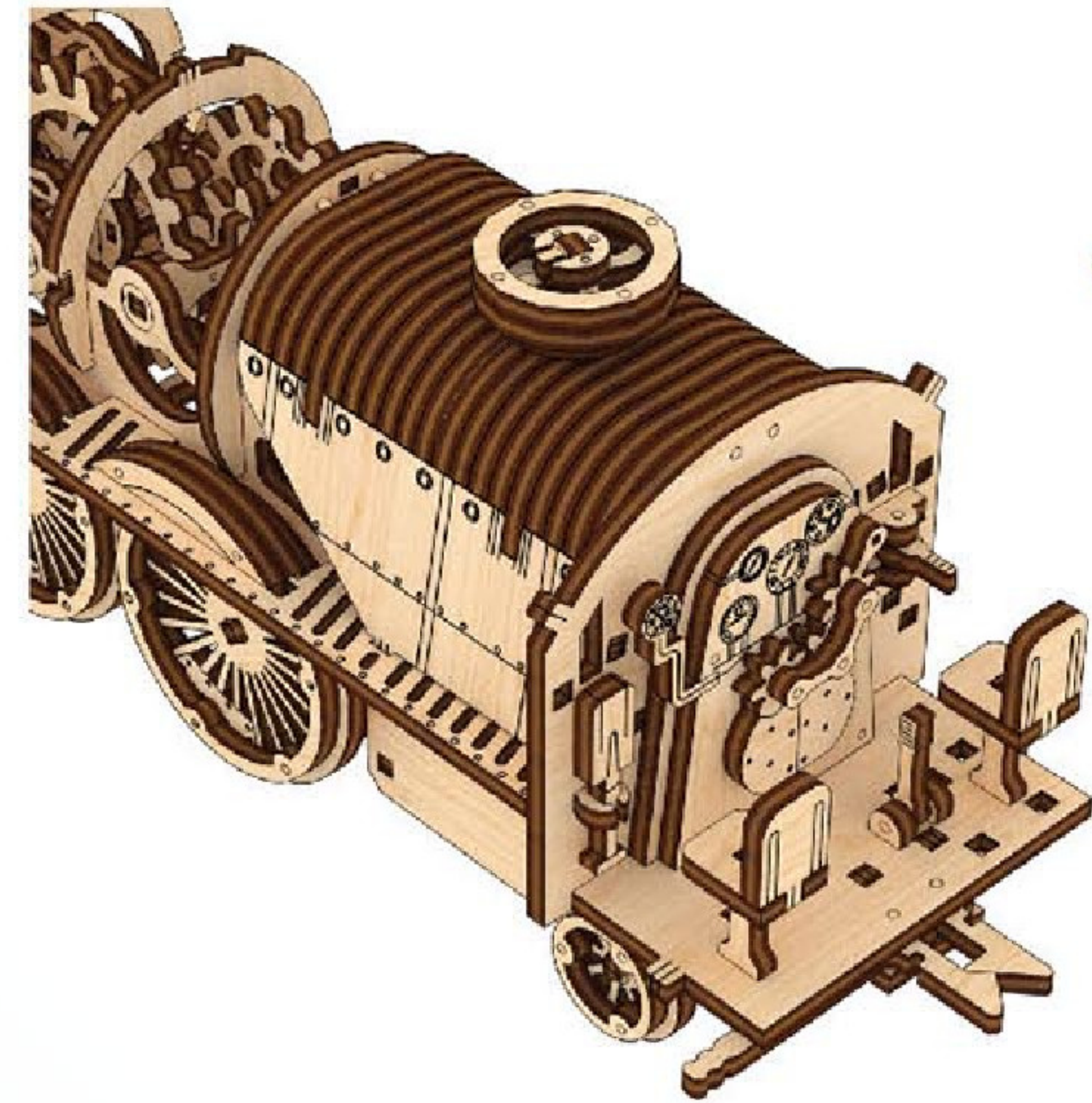

3

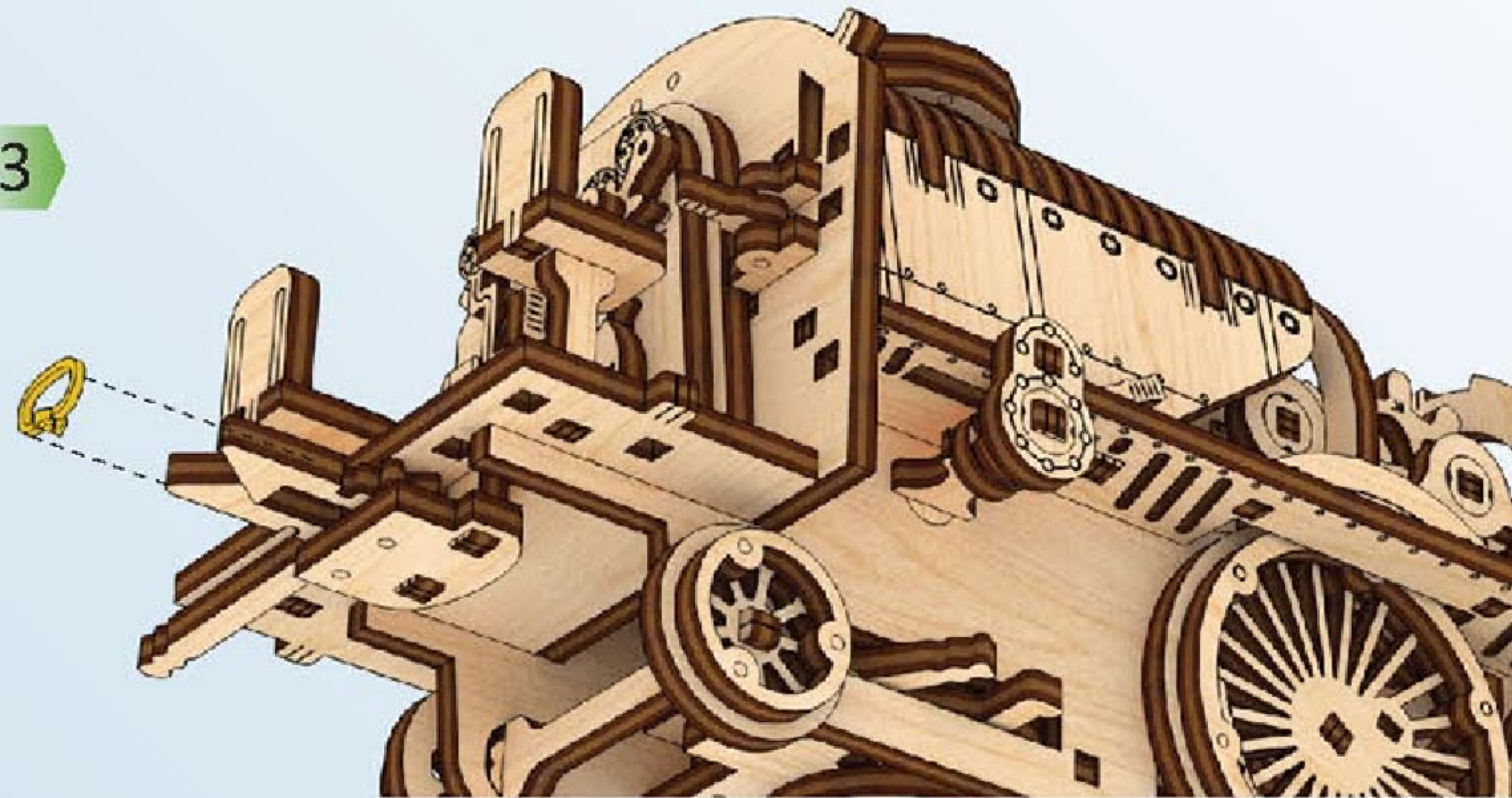

4

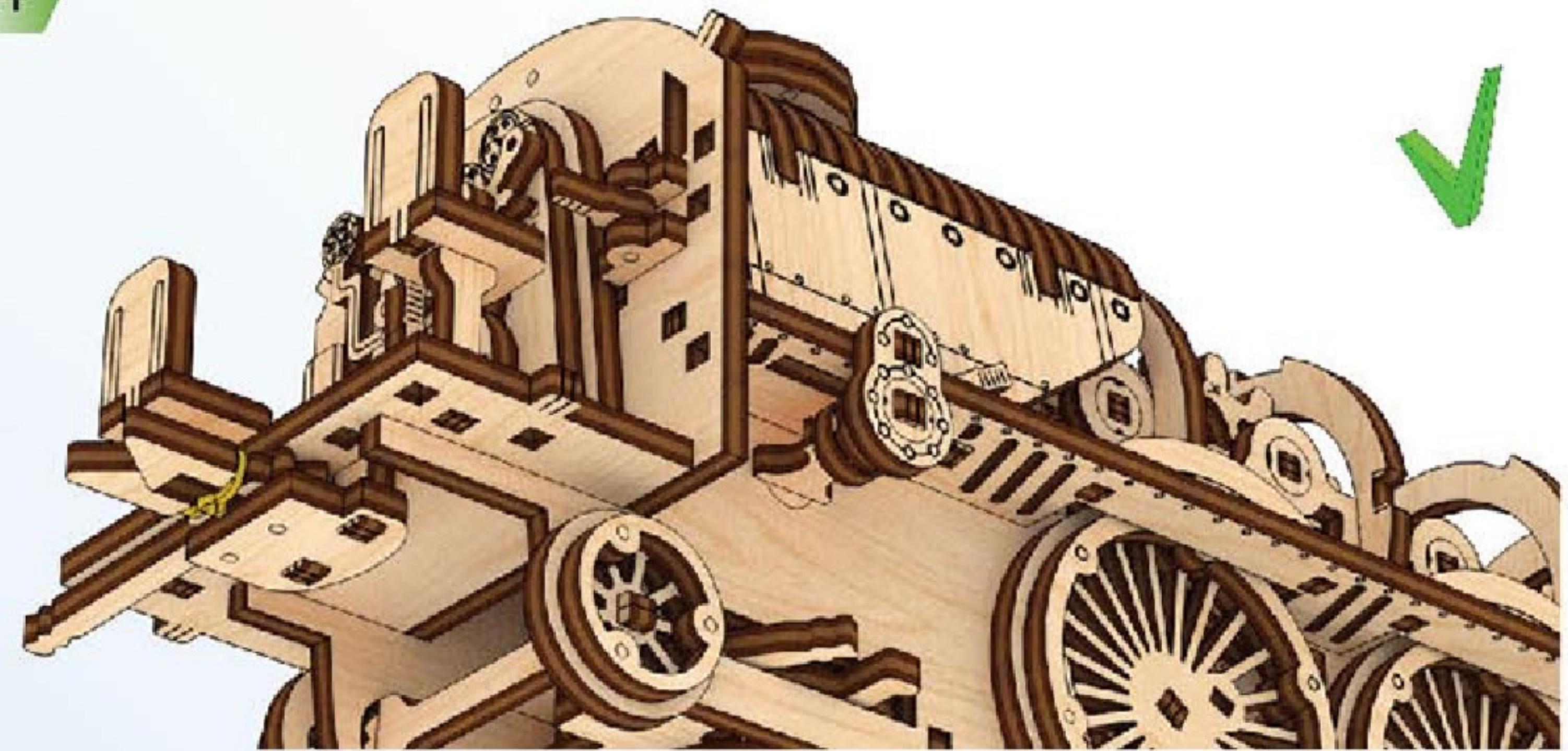

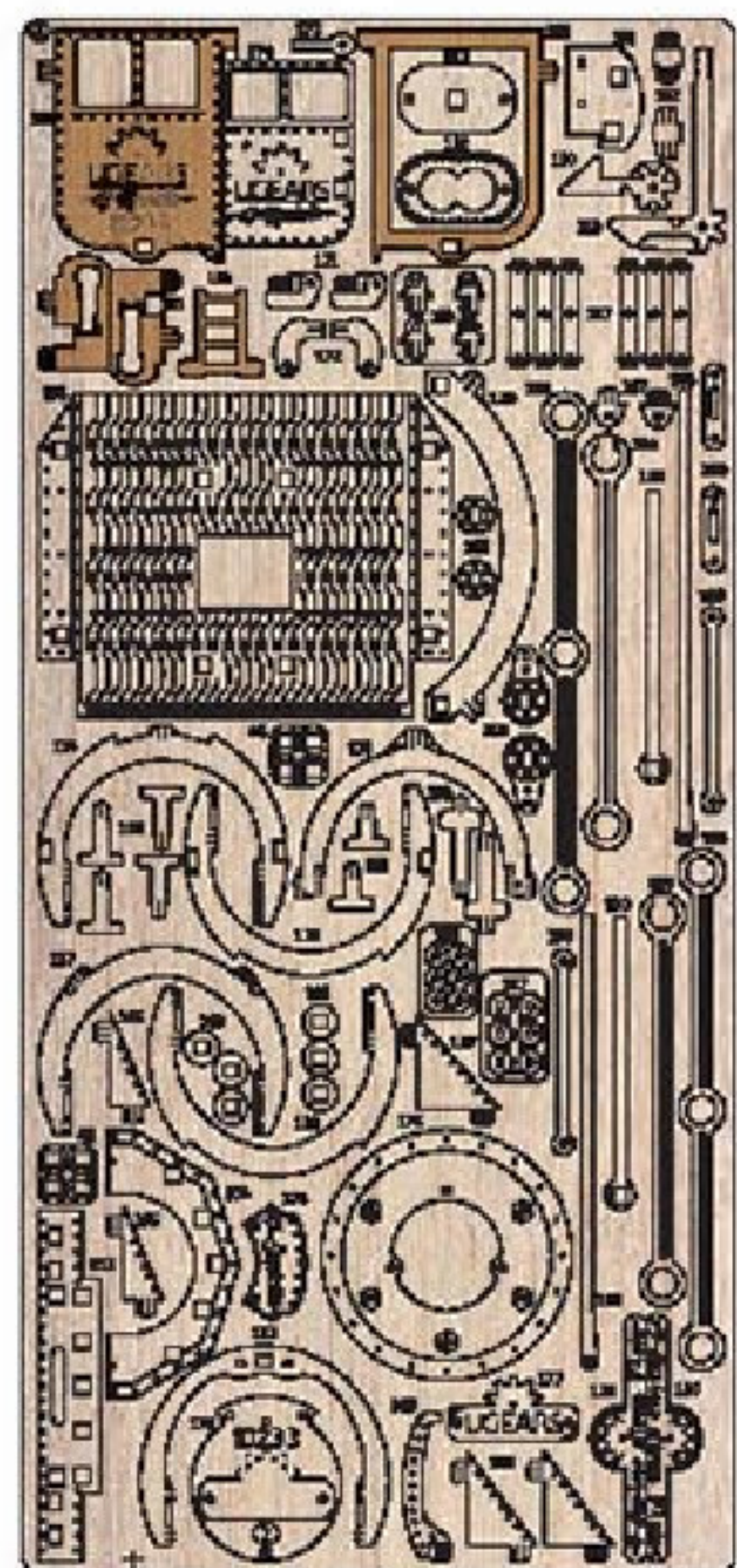

5

1

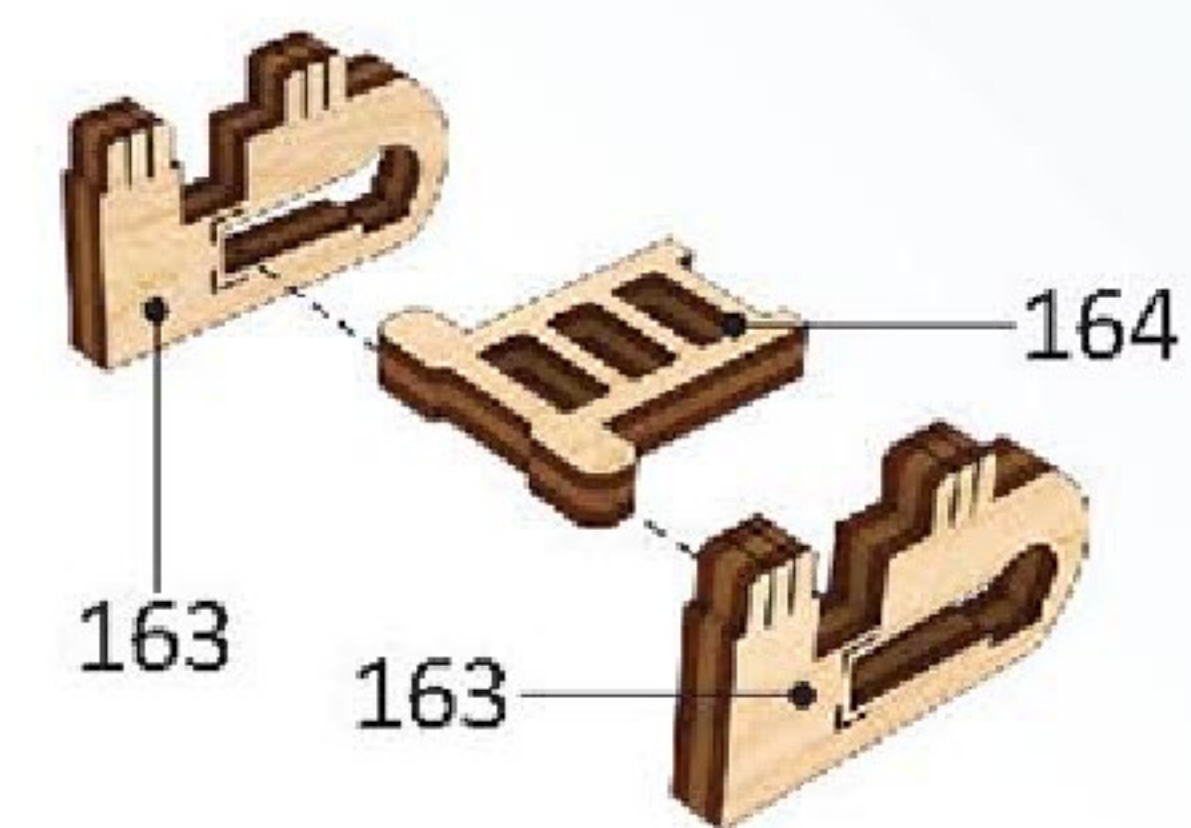

2

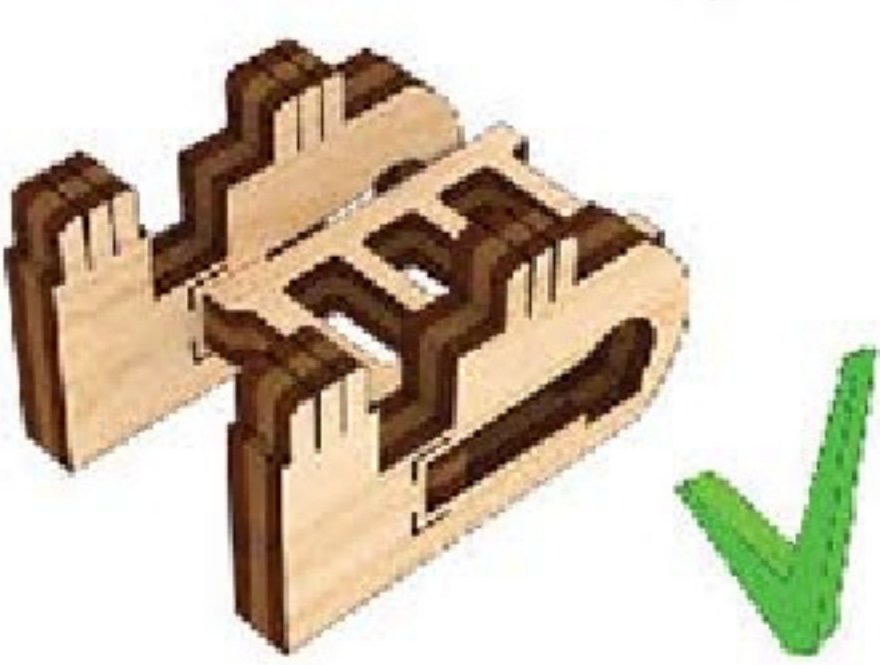

3

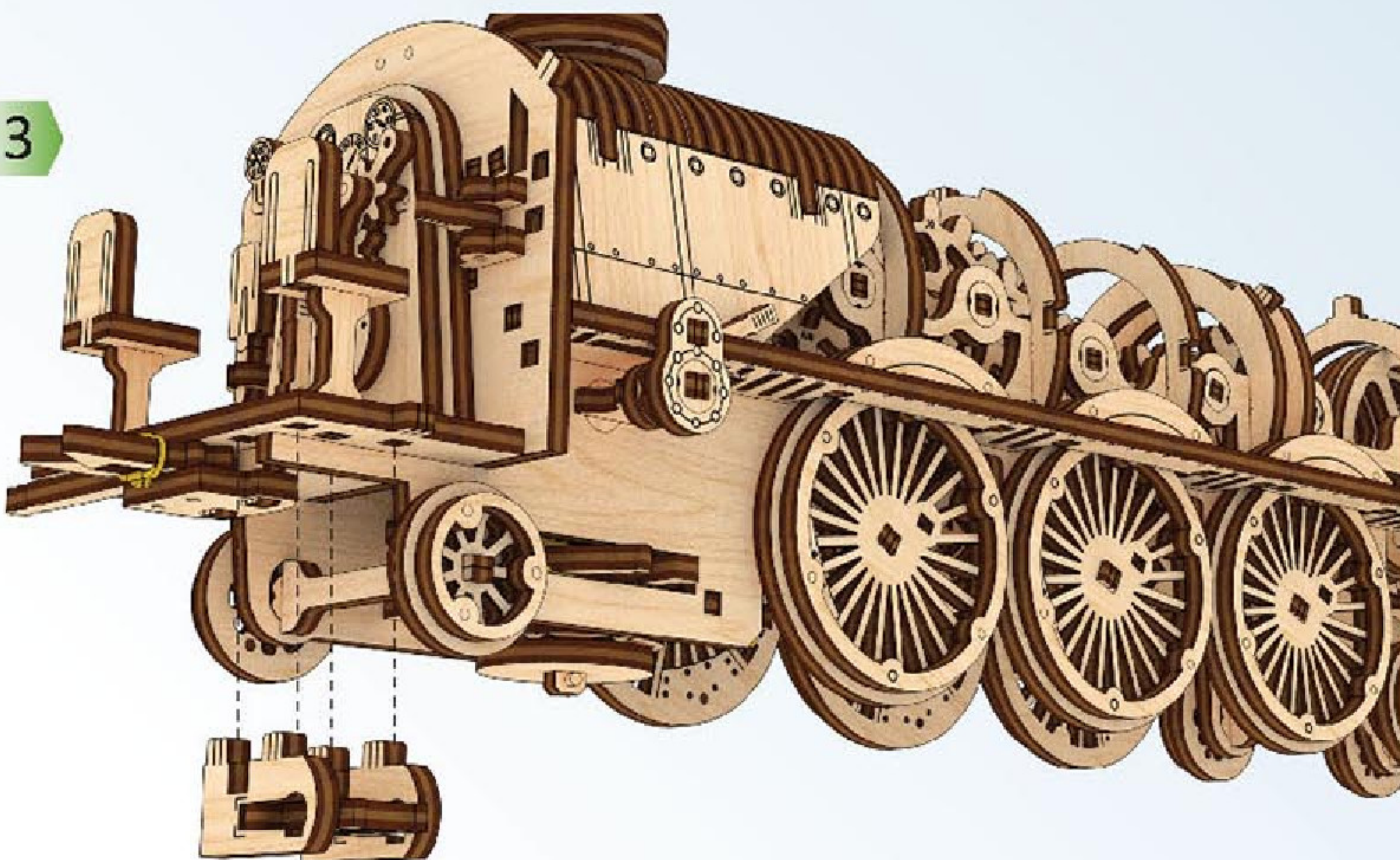

4

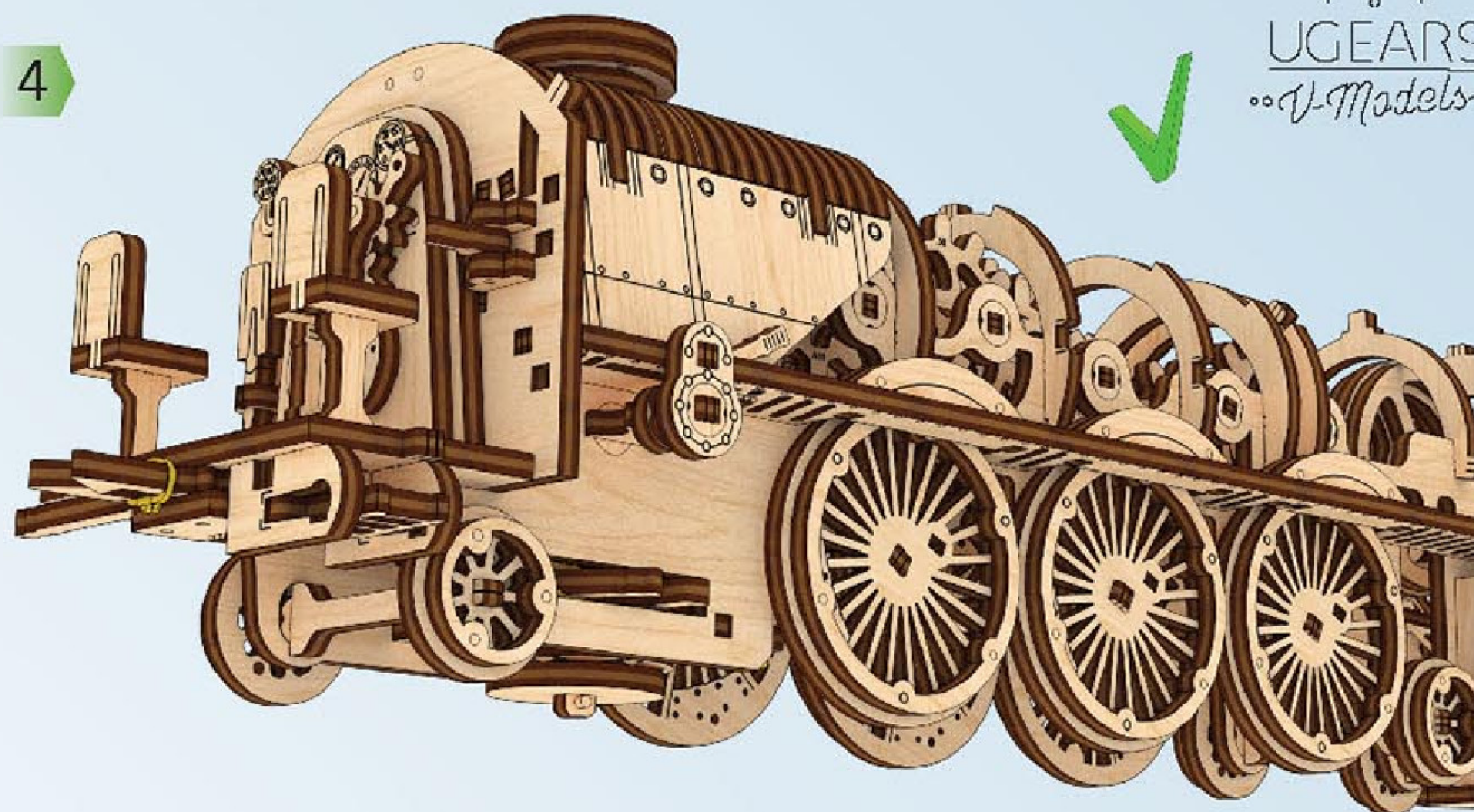

5

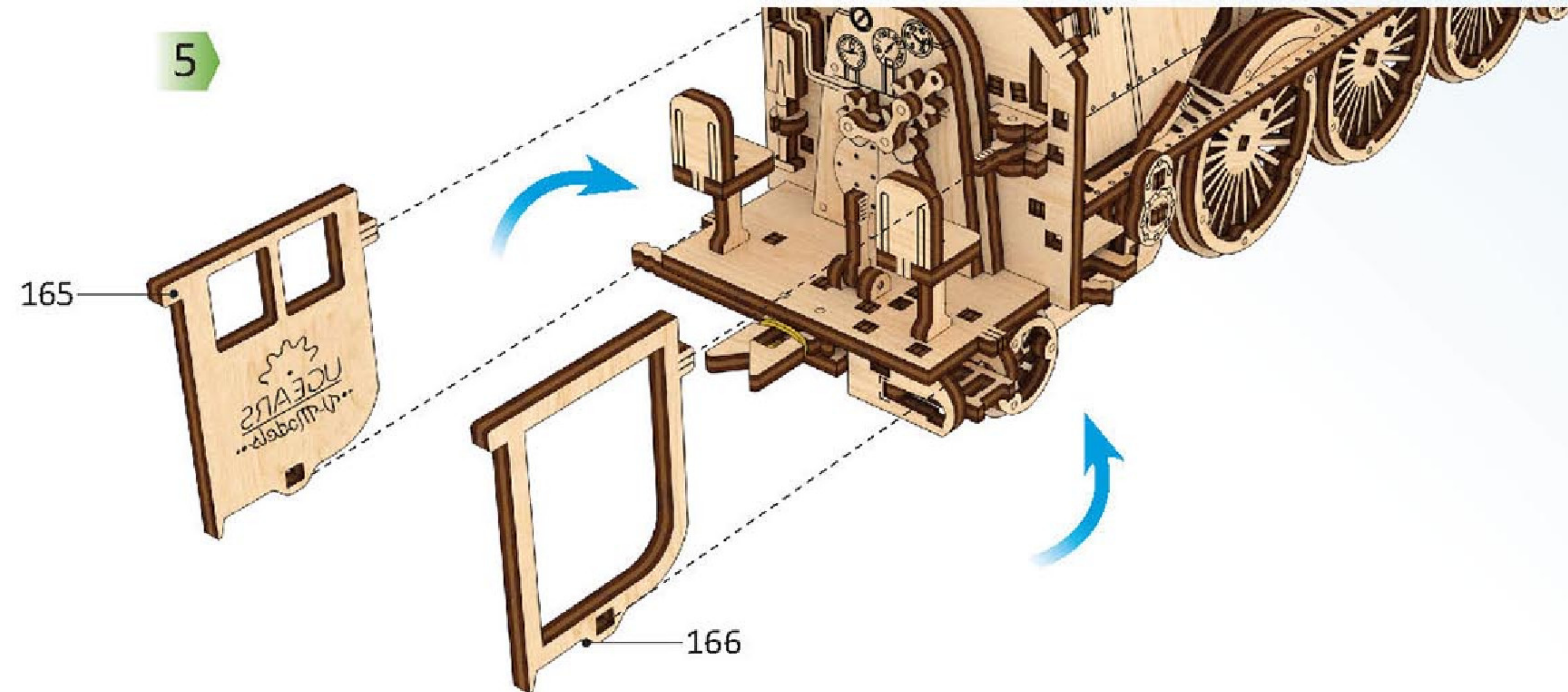

6

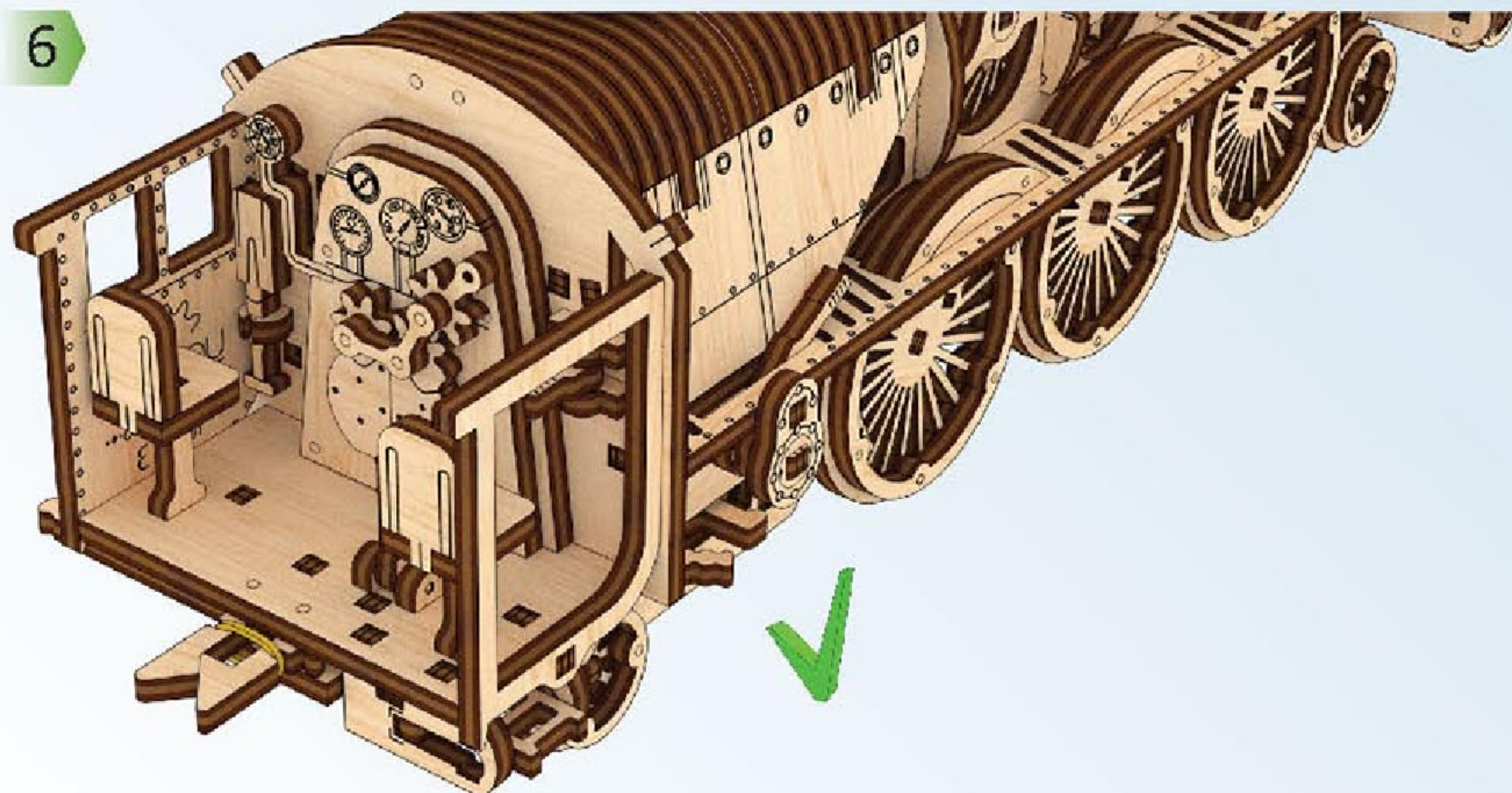

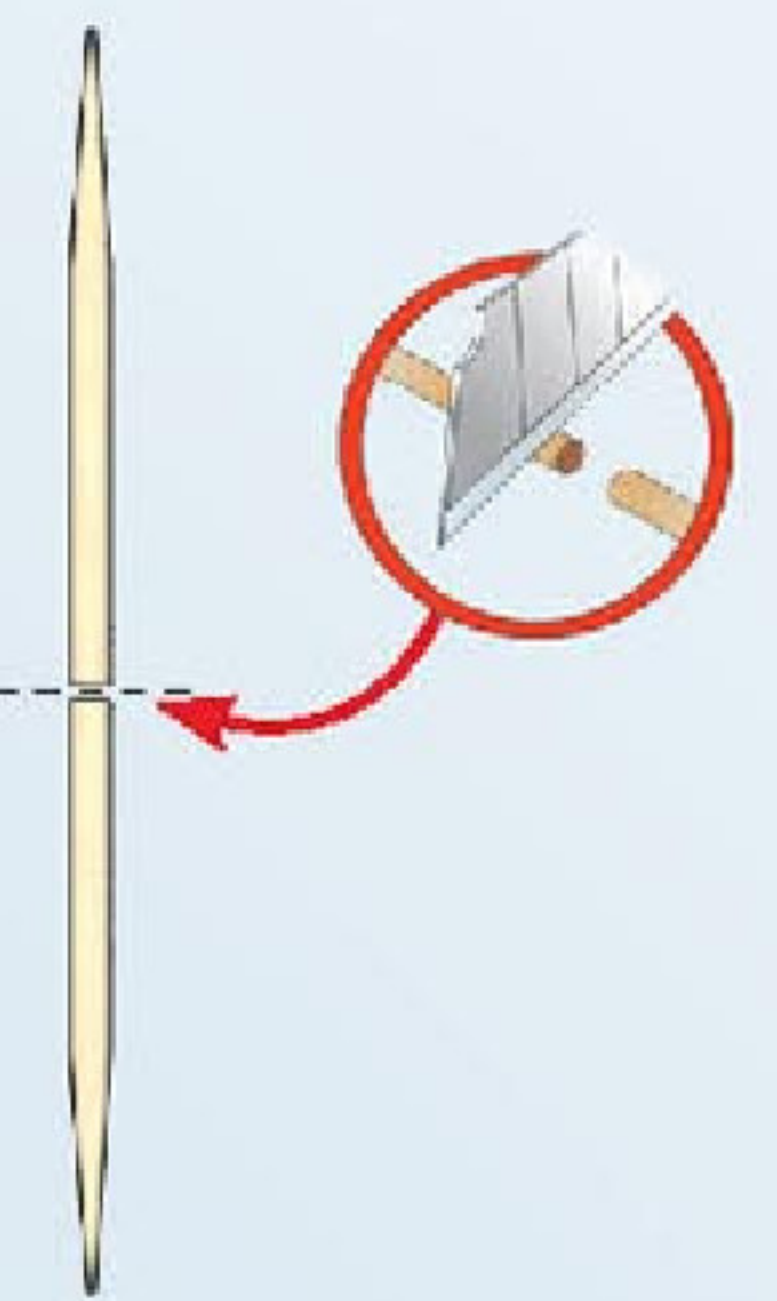
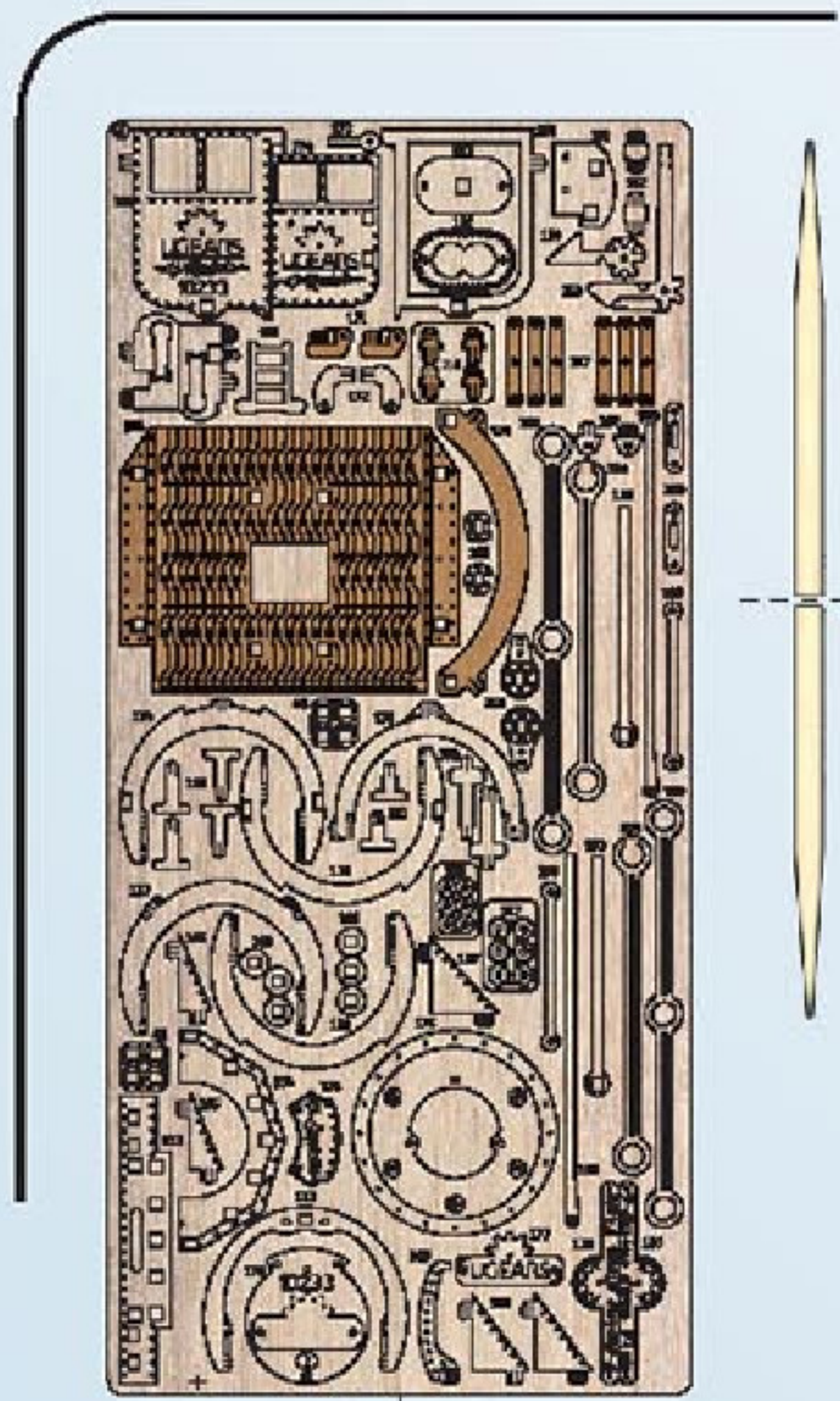

1

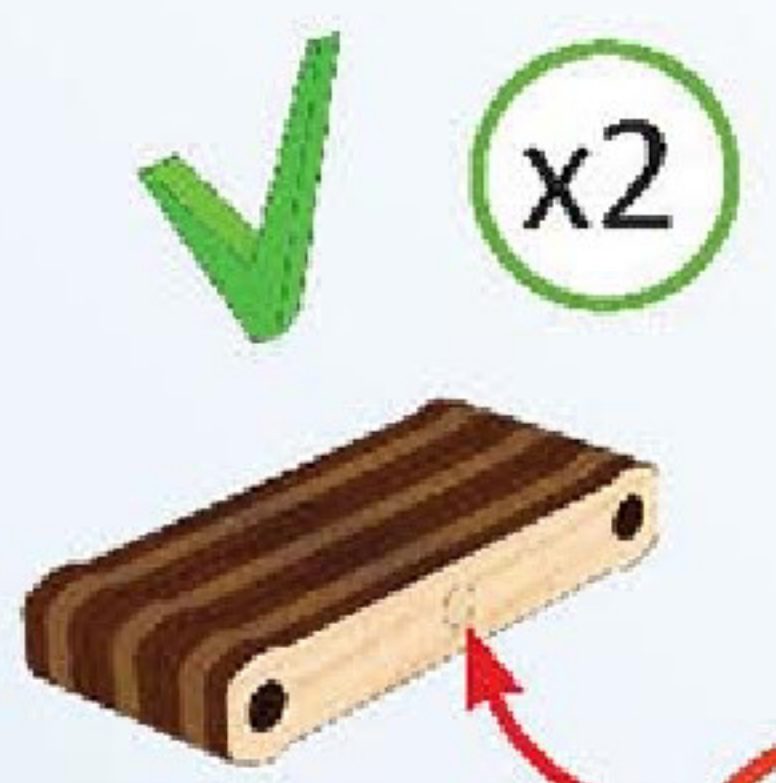
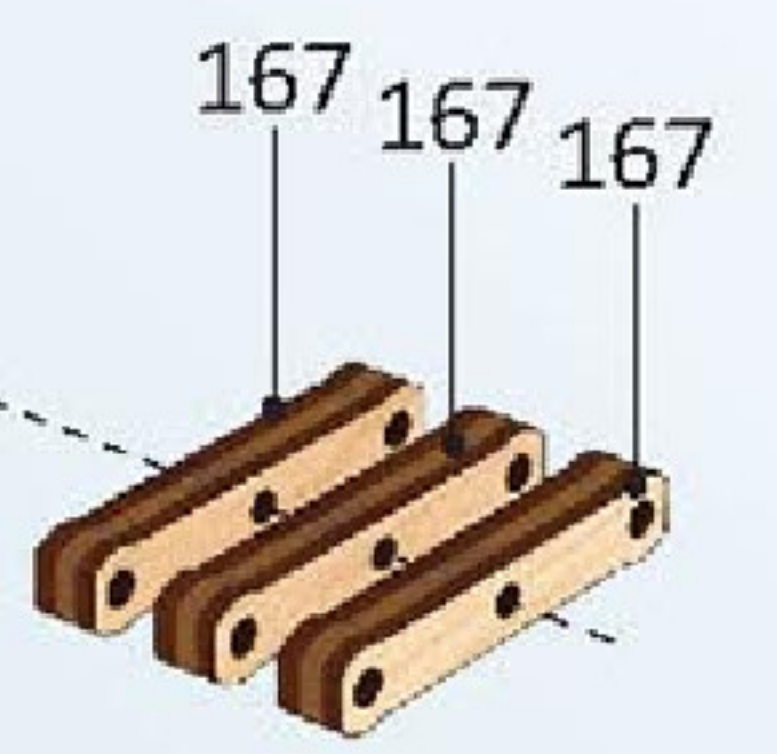

2

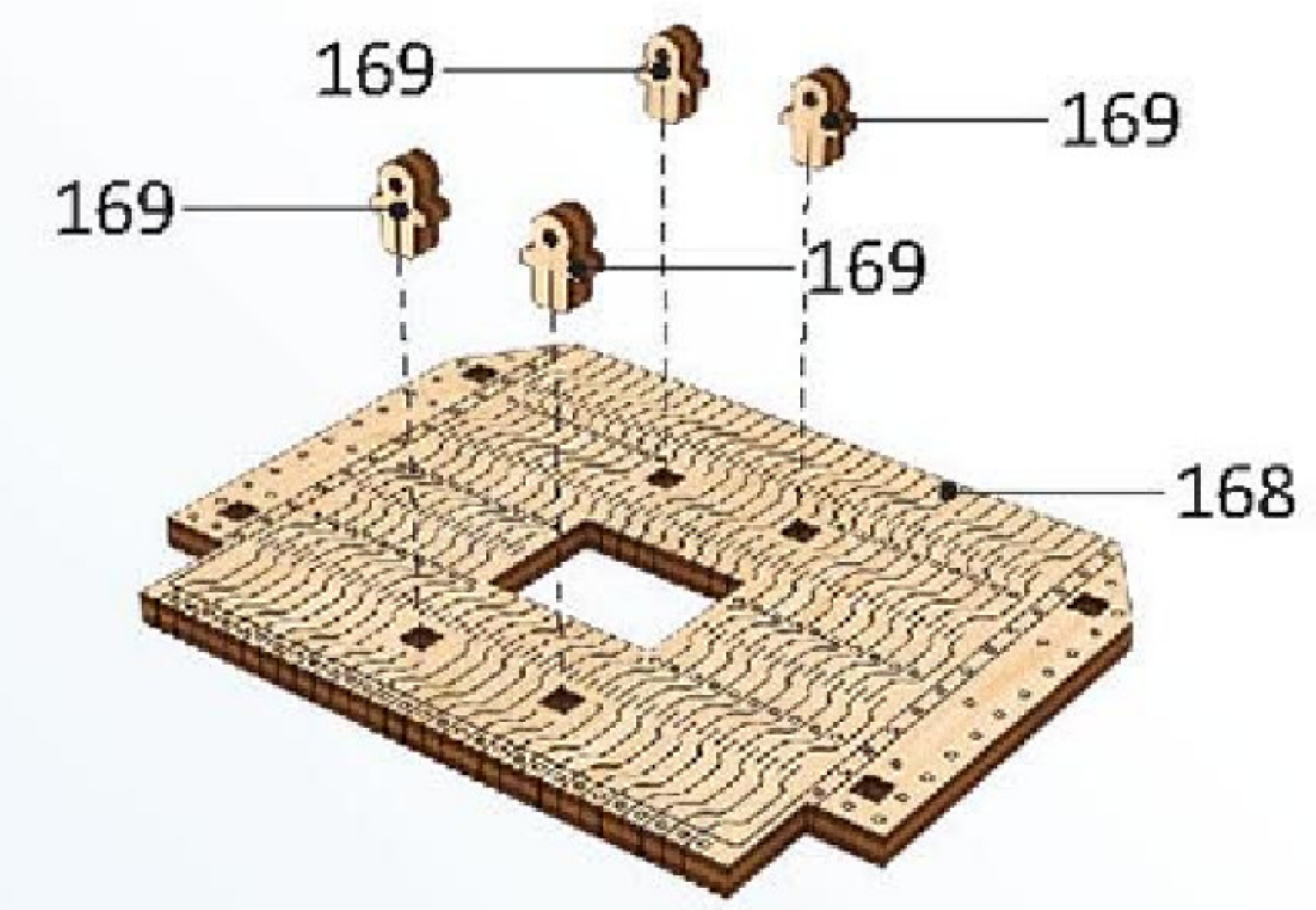

3

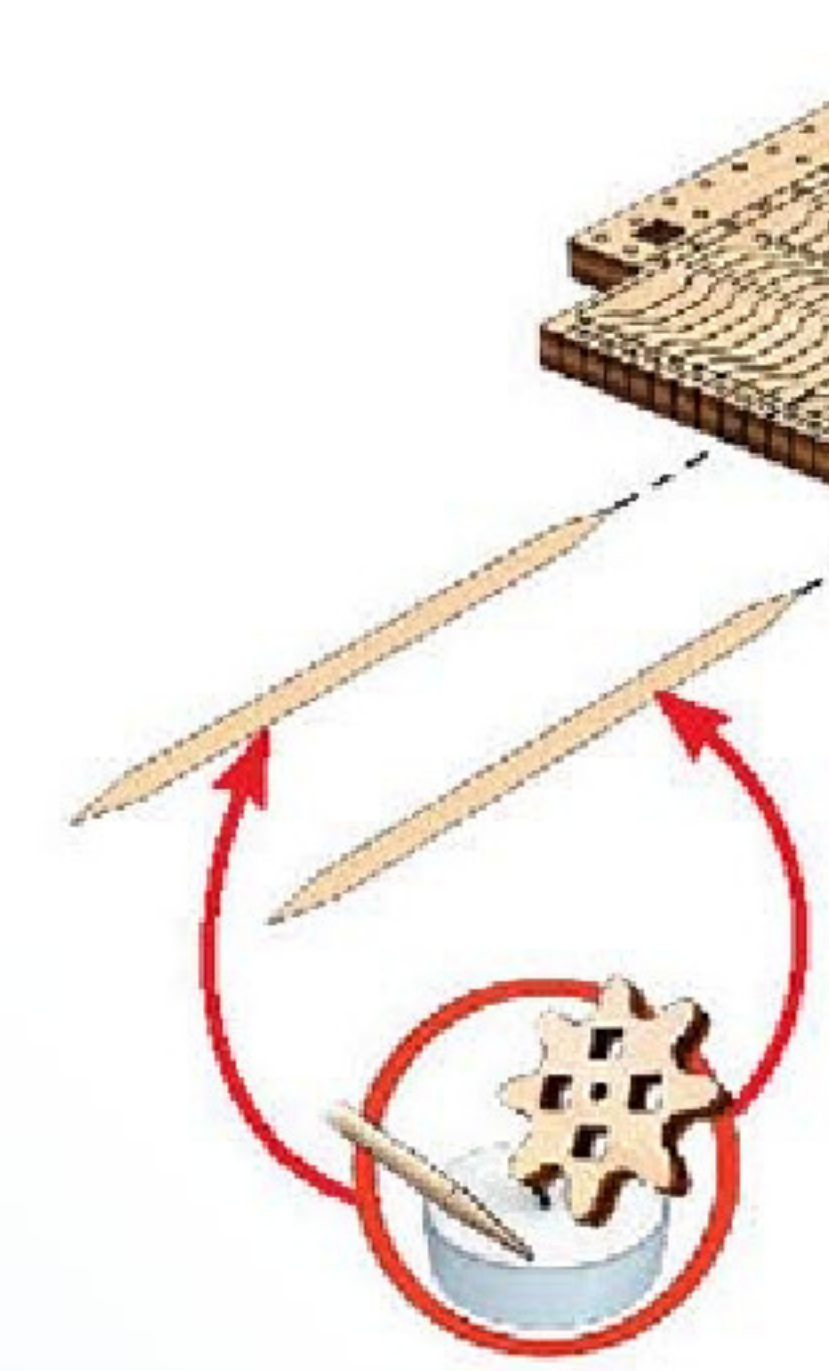

4

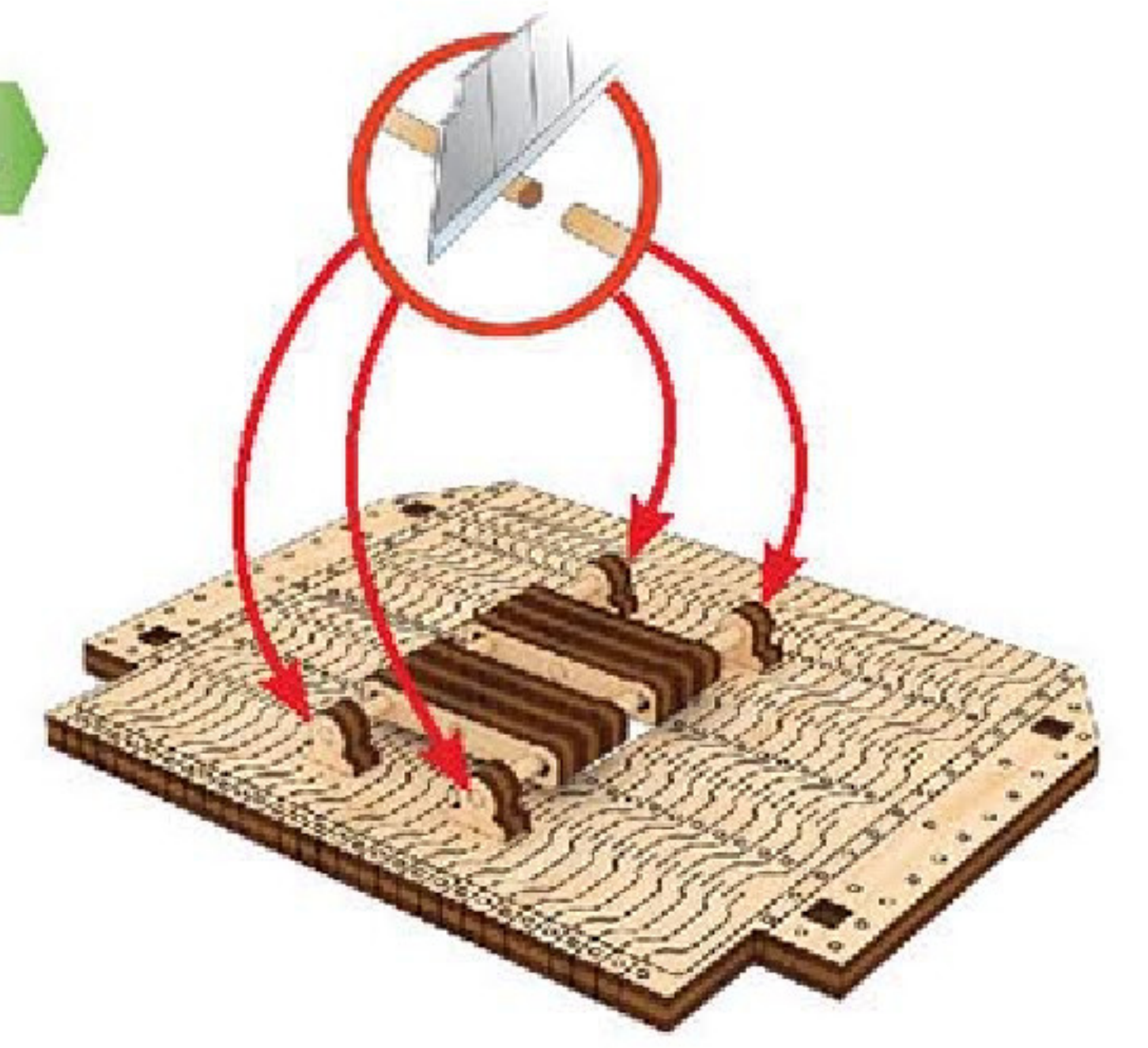

5

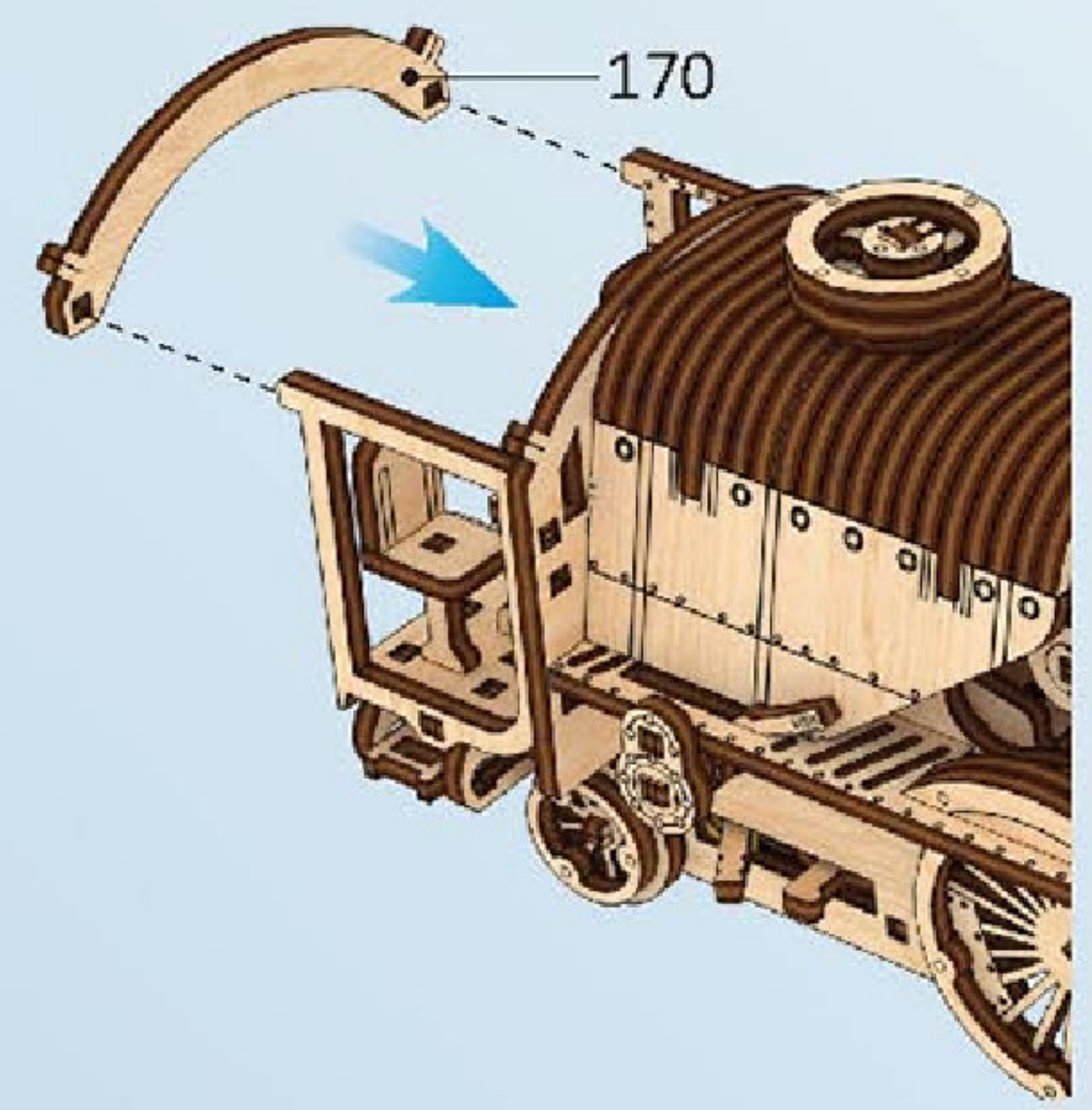

6

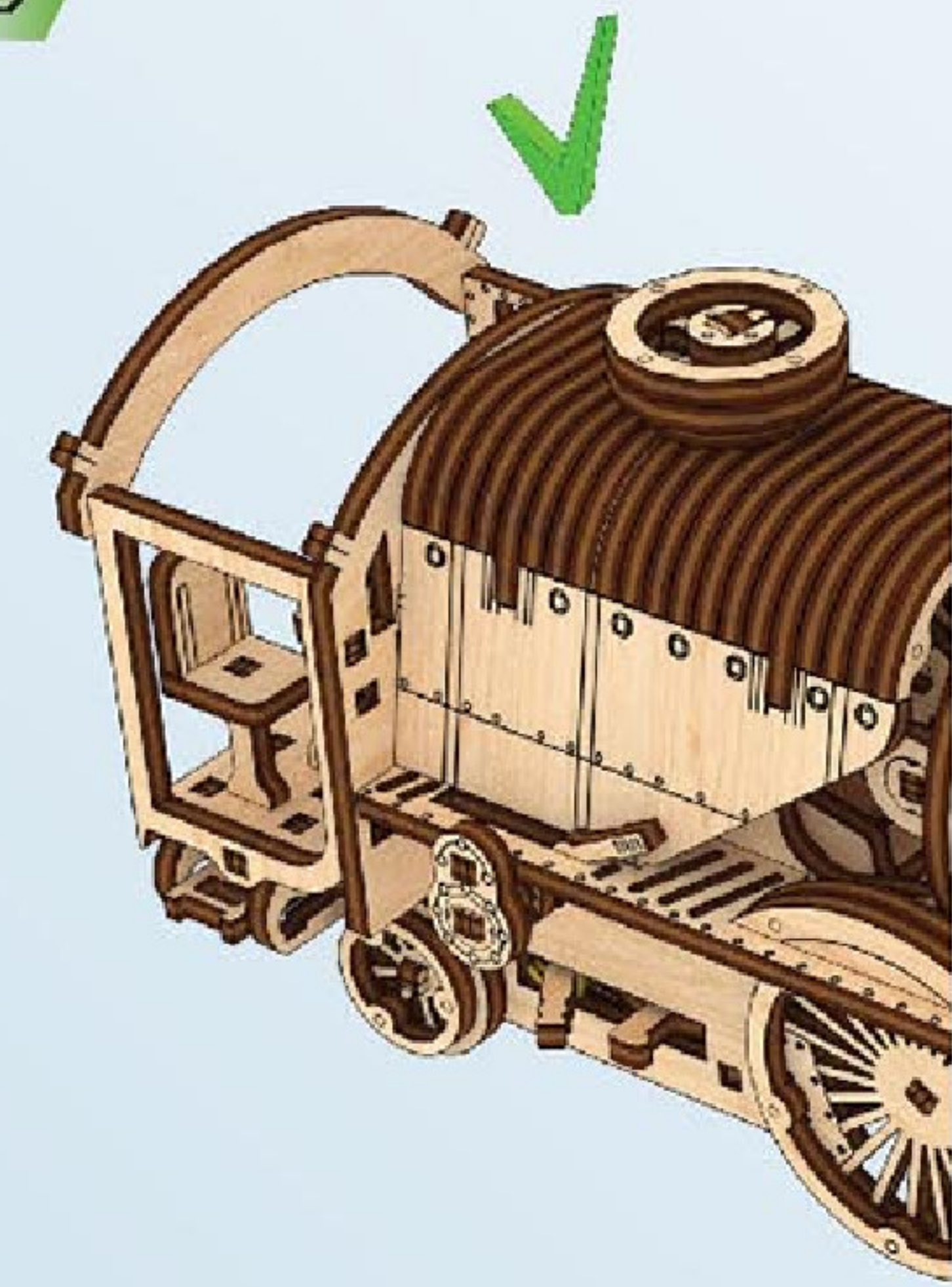

7

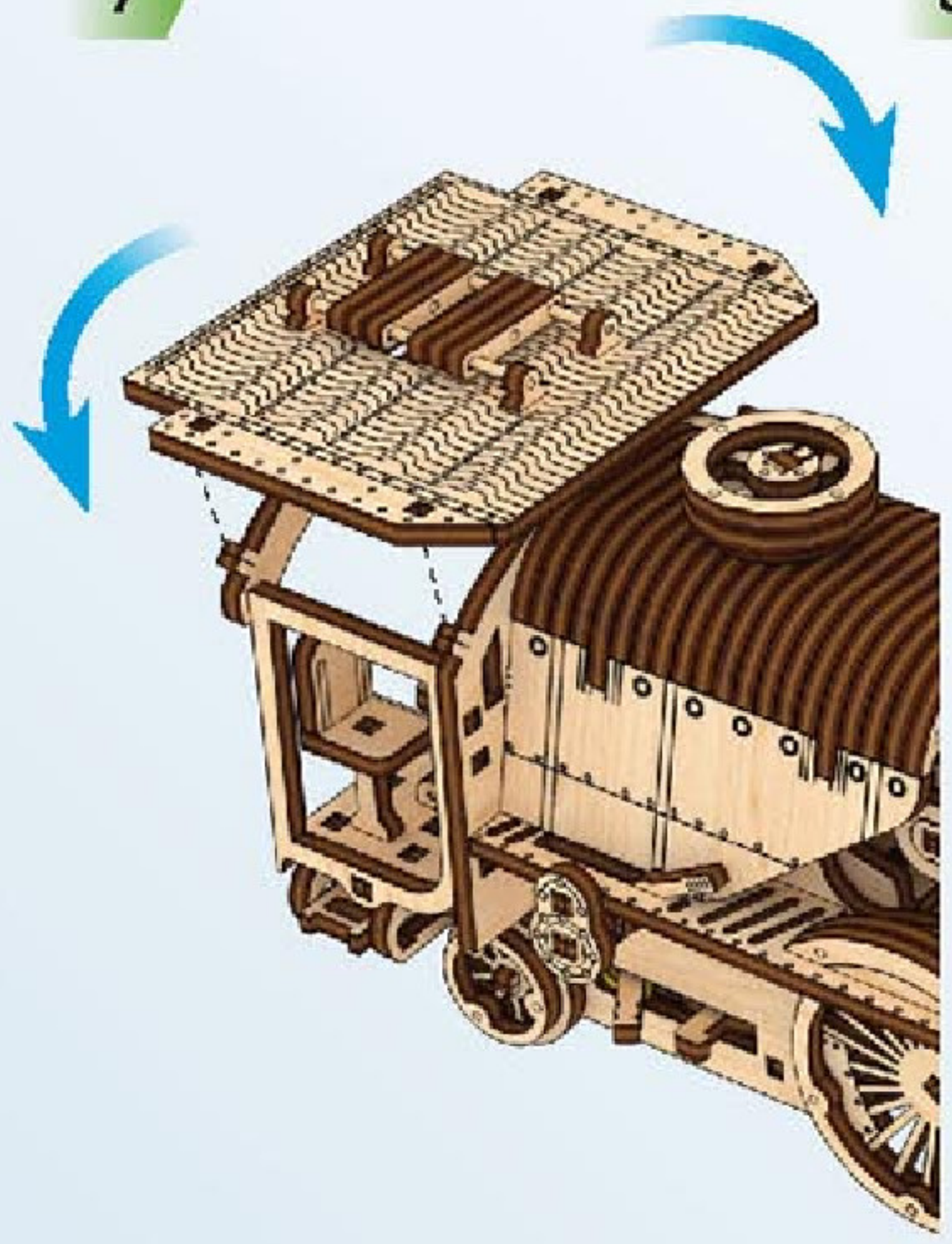

8

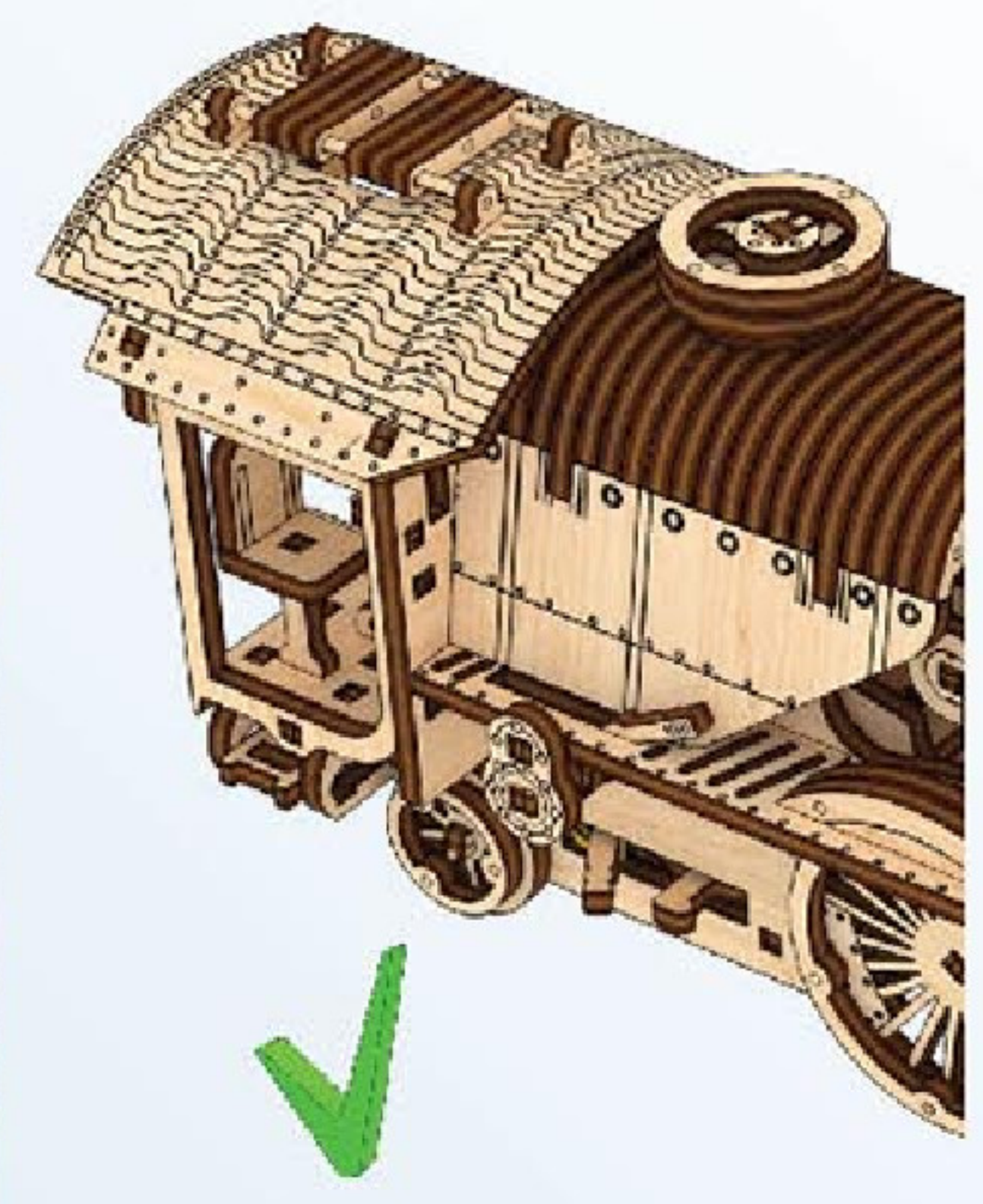

9

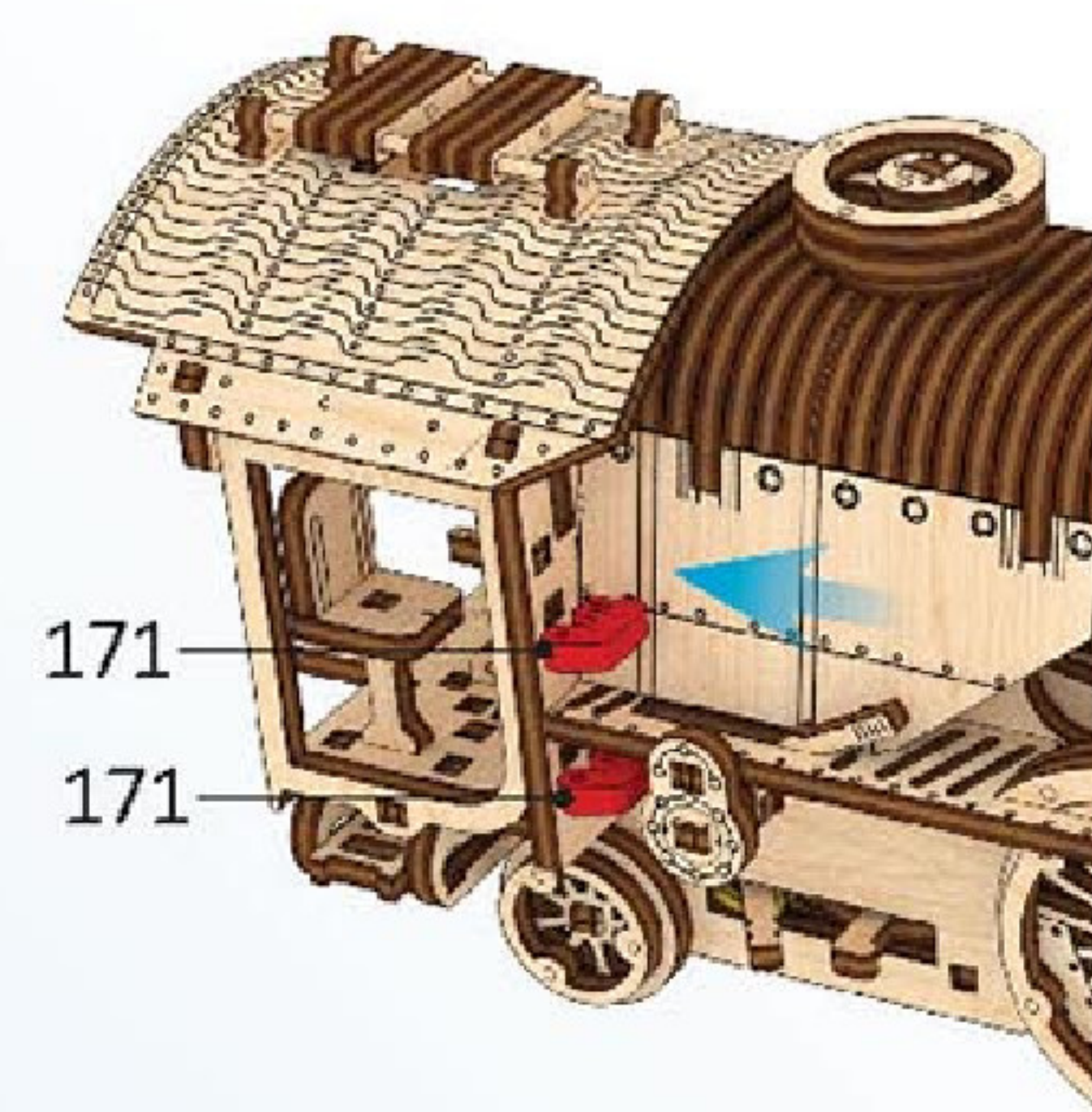

10

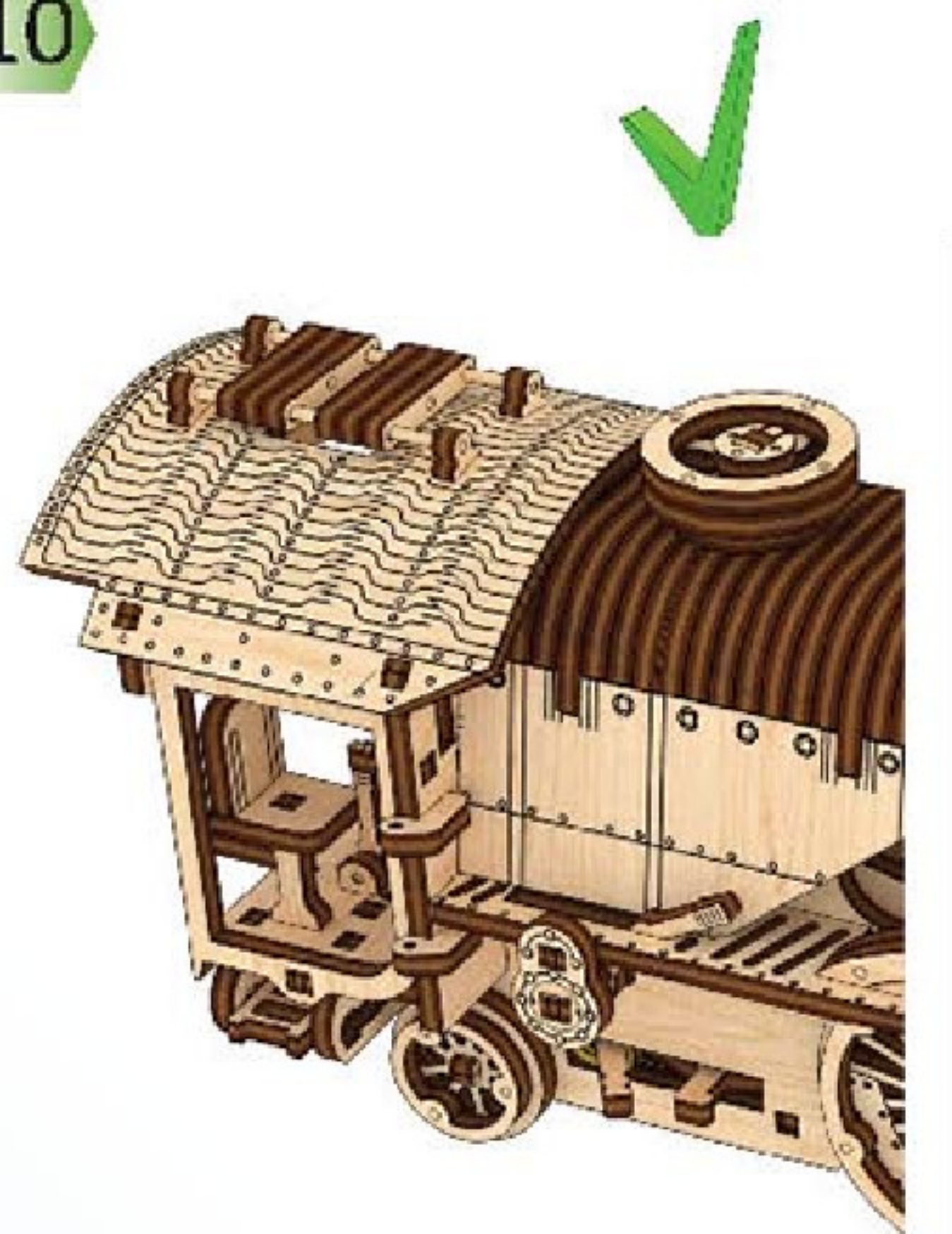

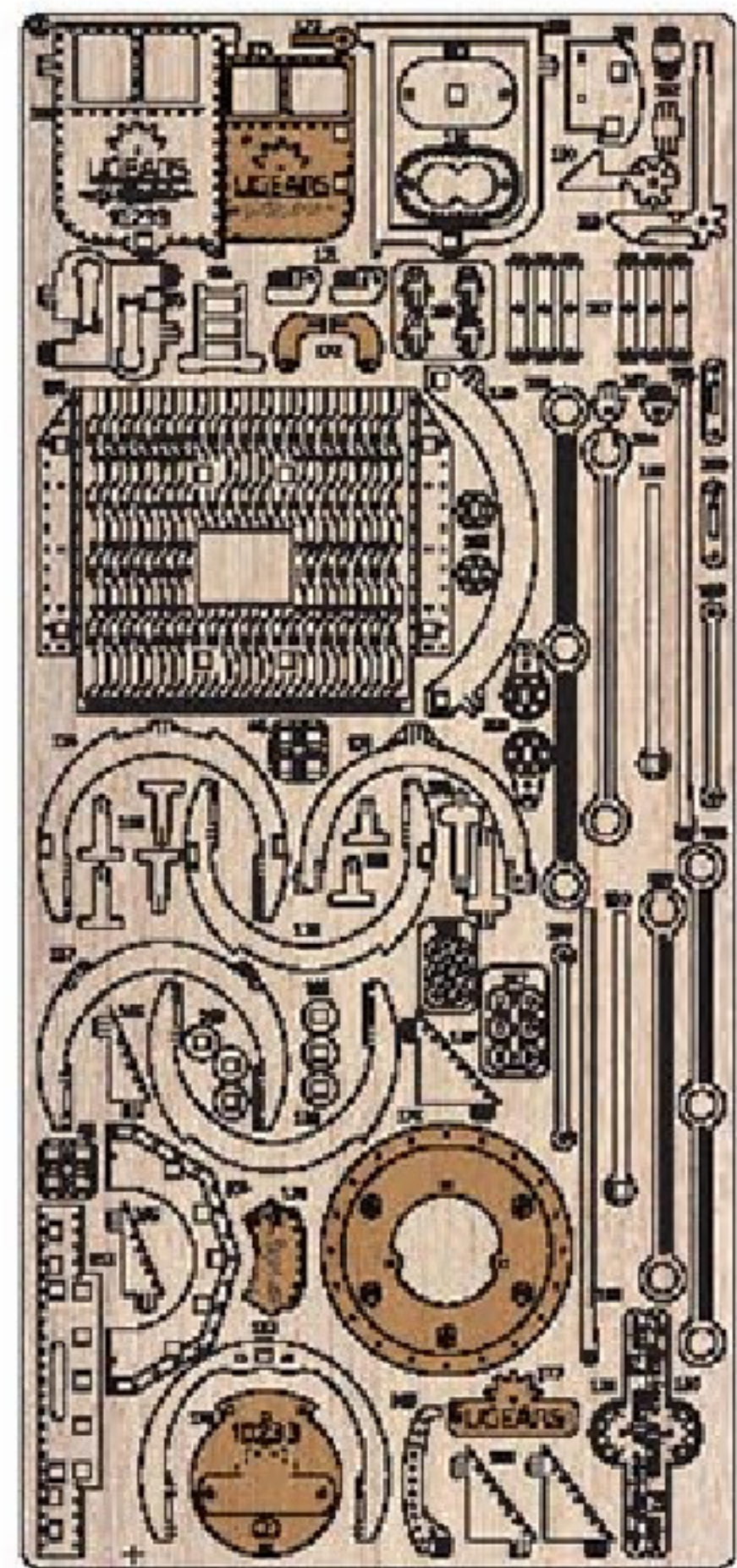

5

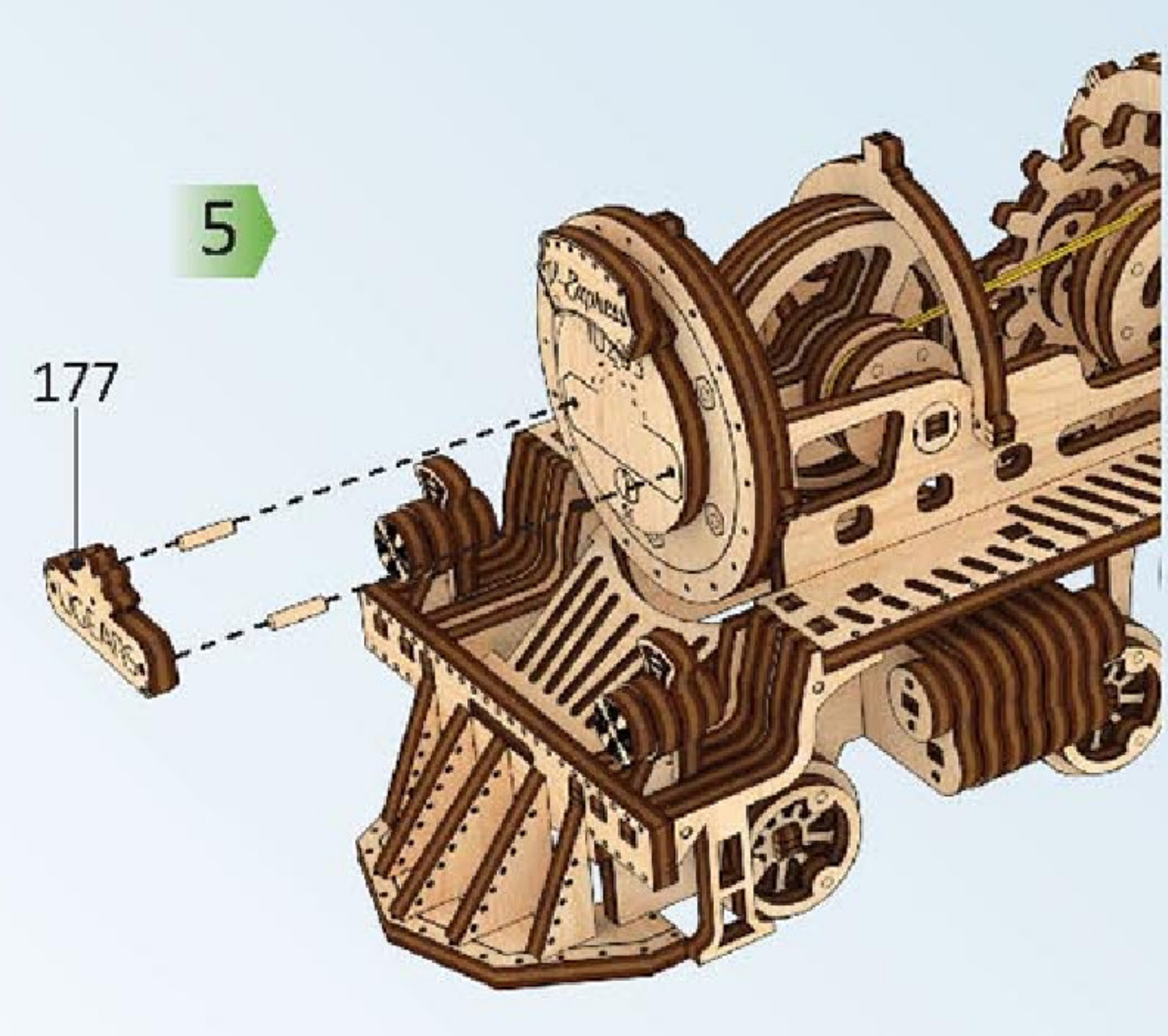
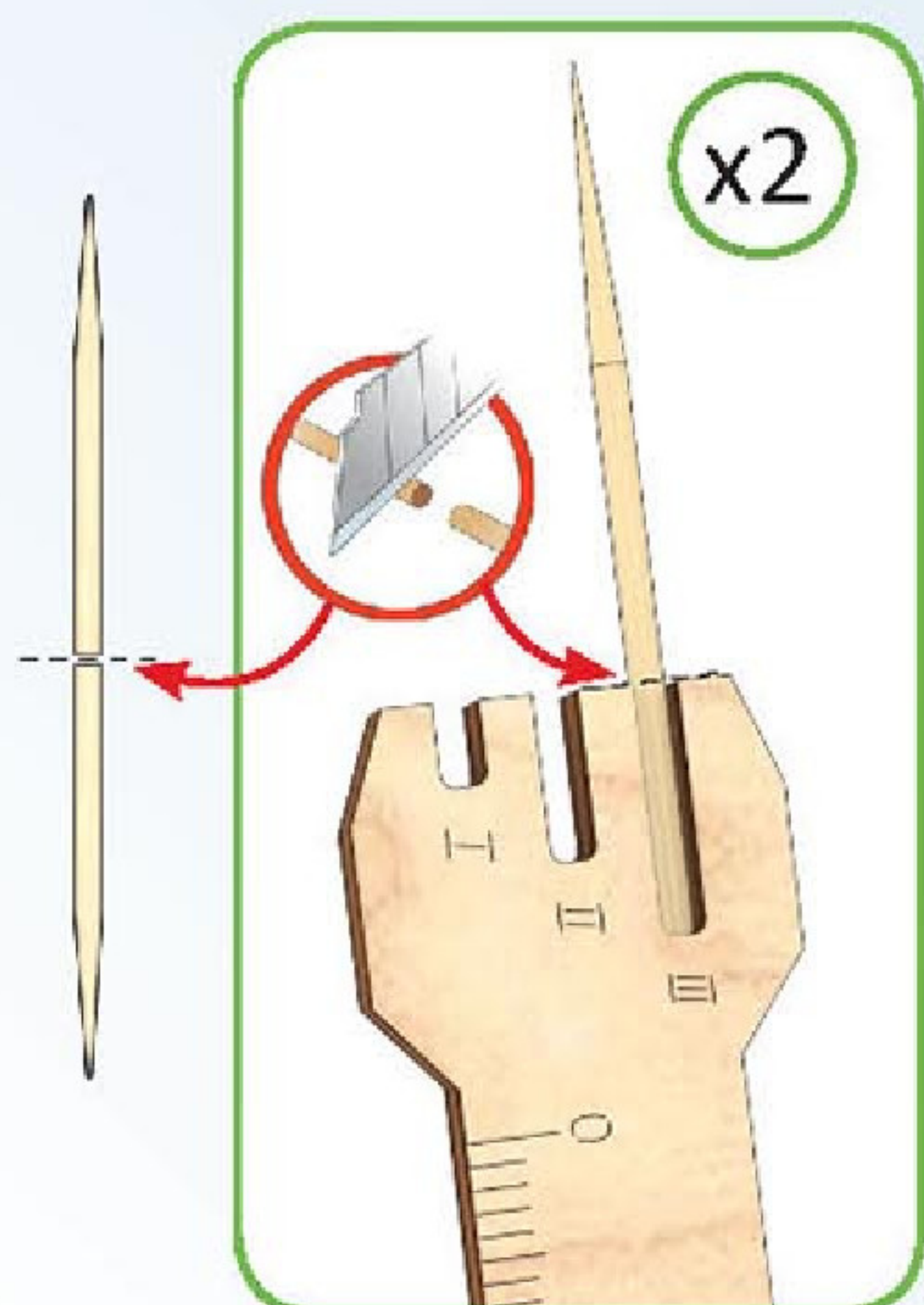
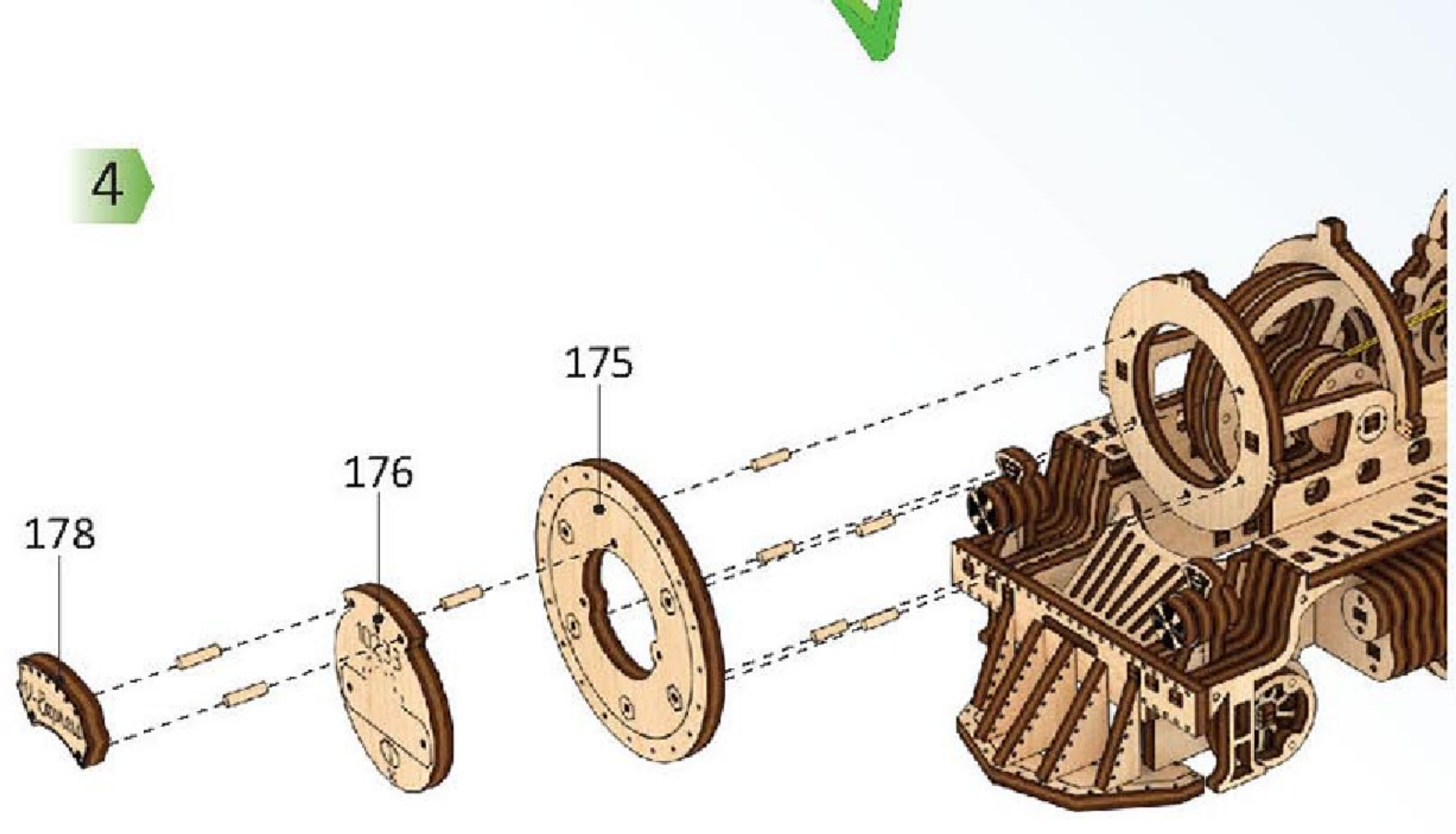
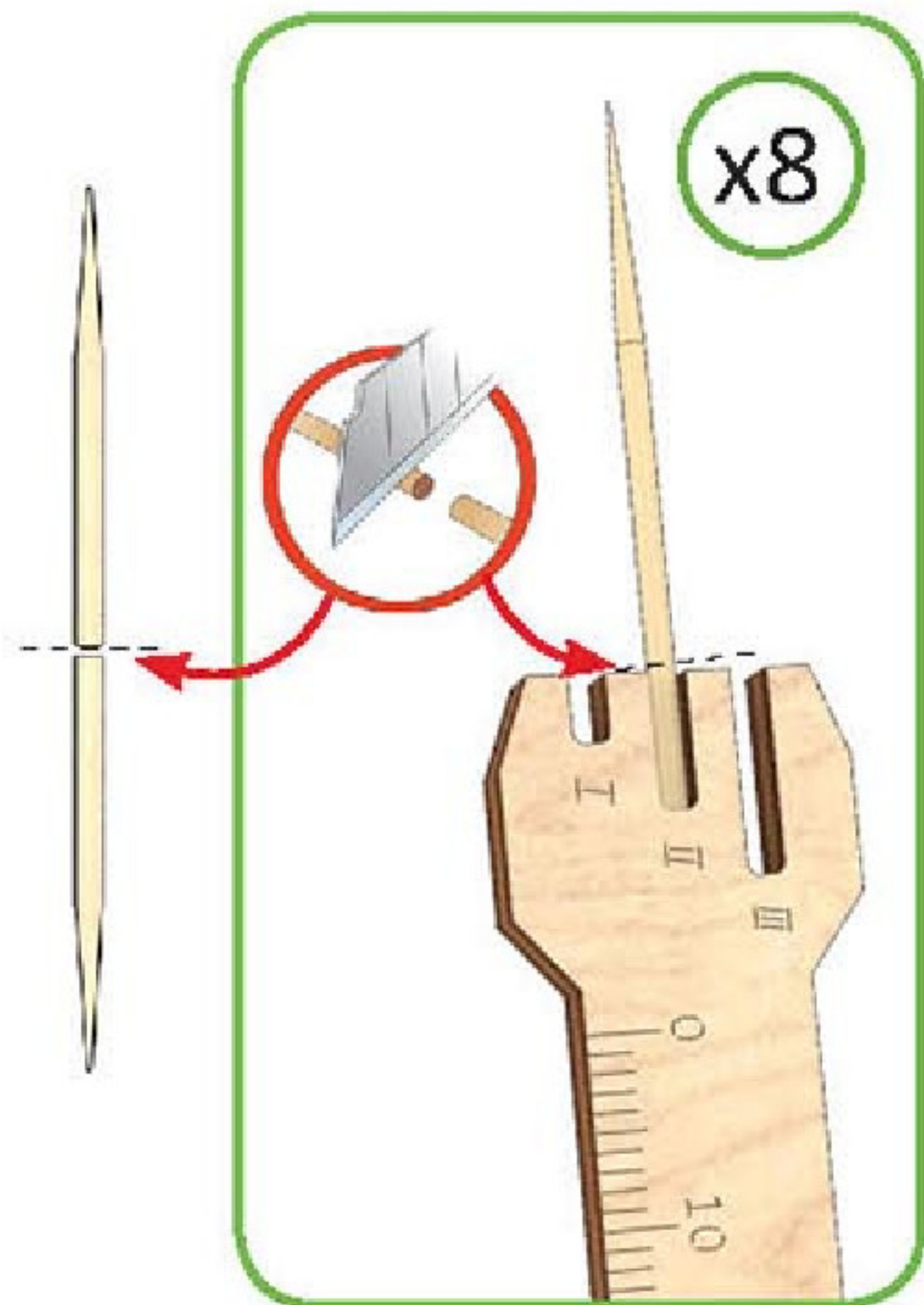
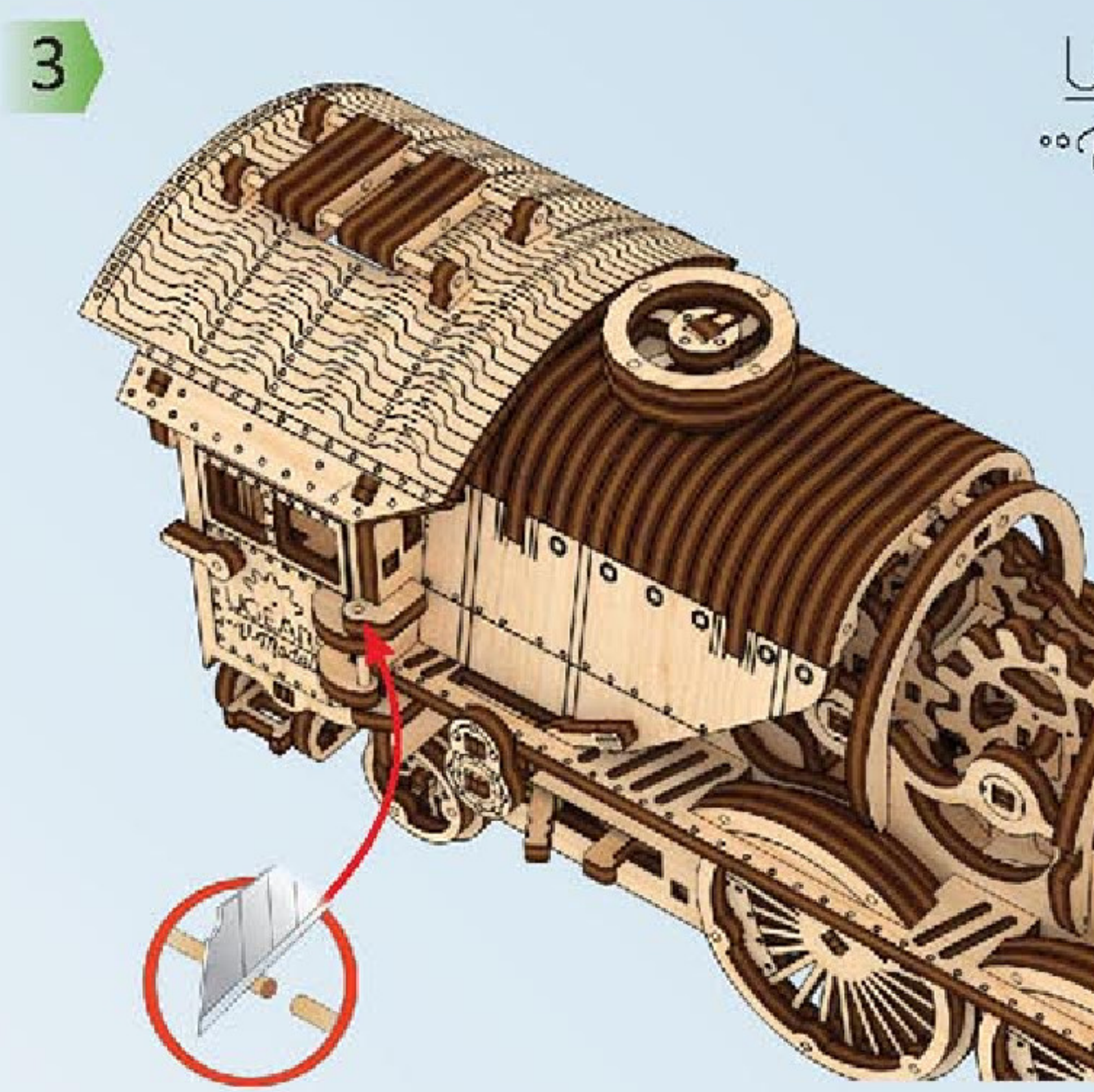
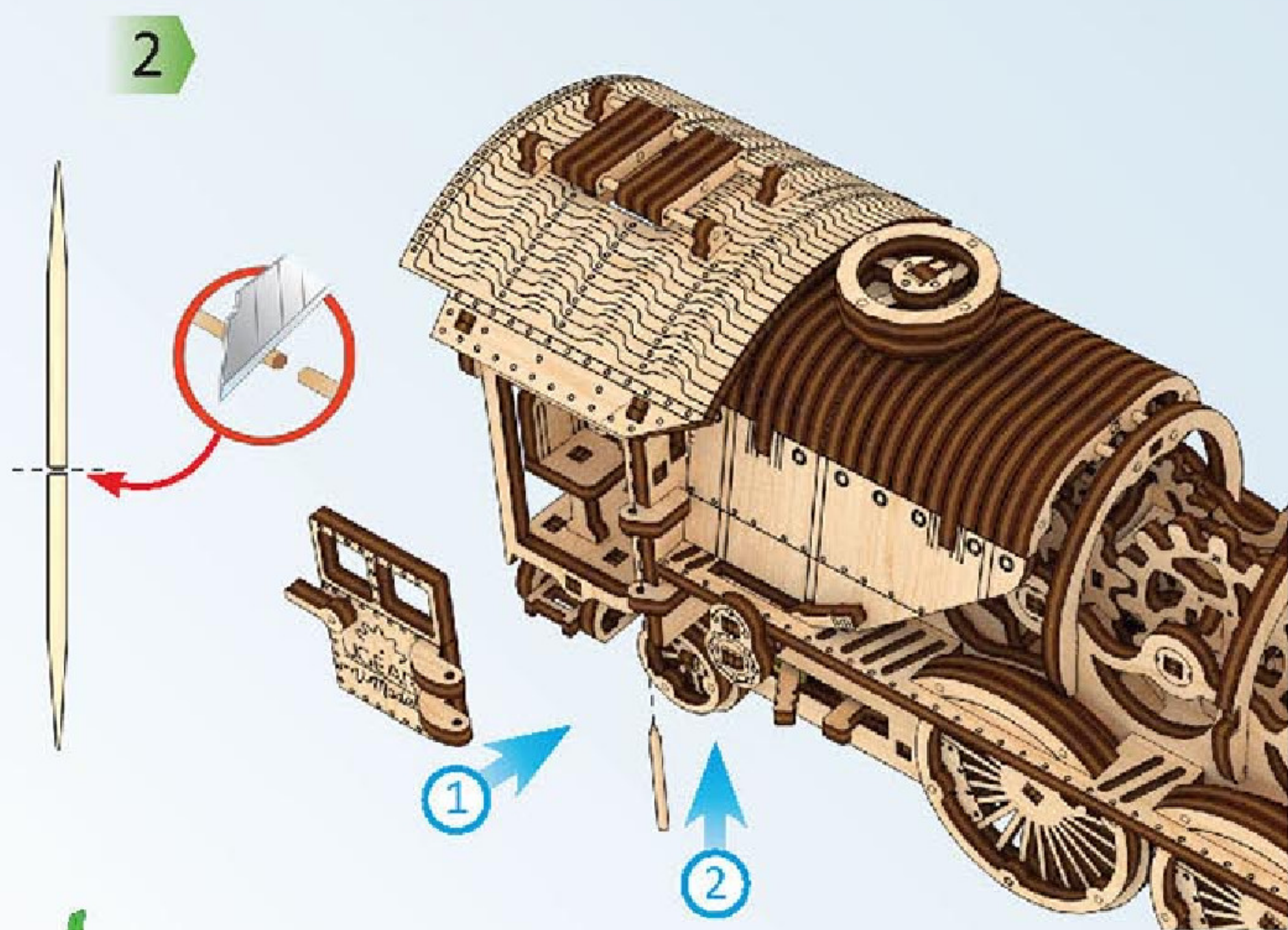
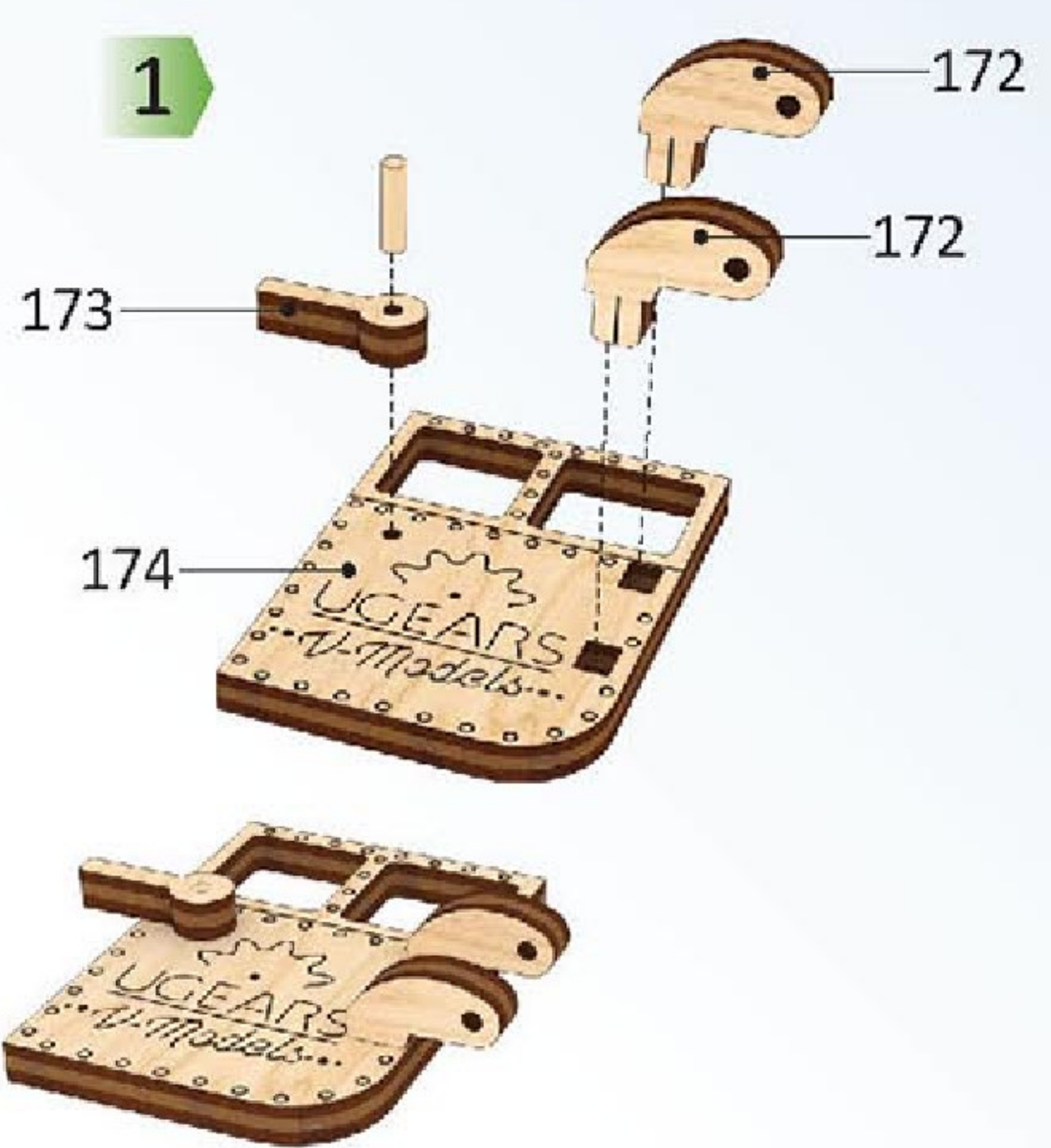
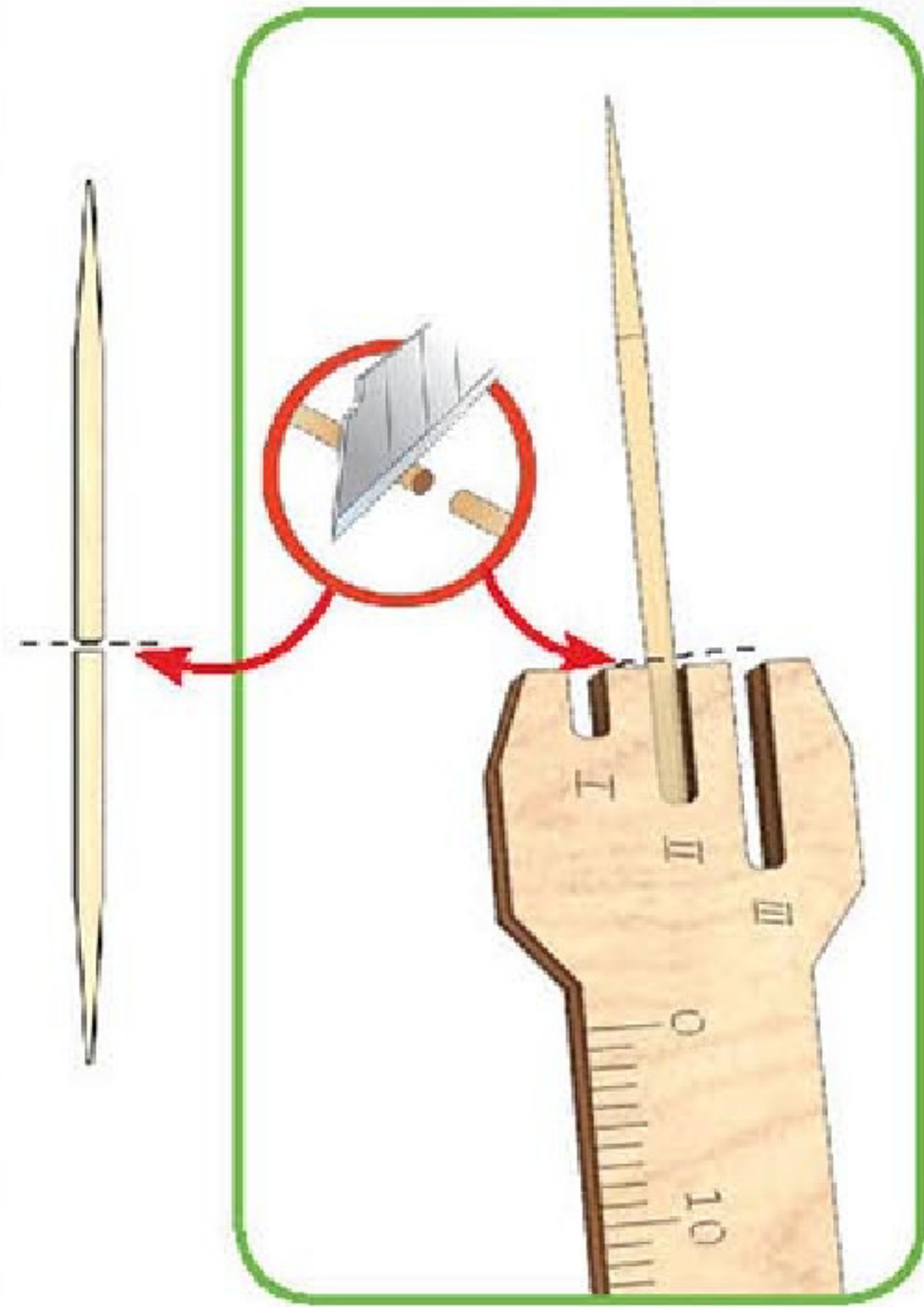

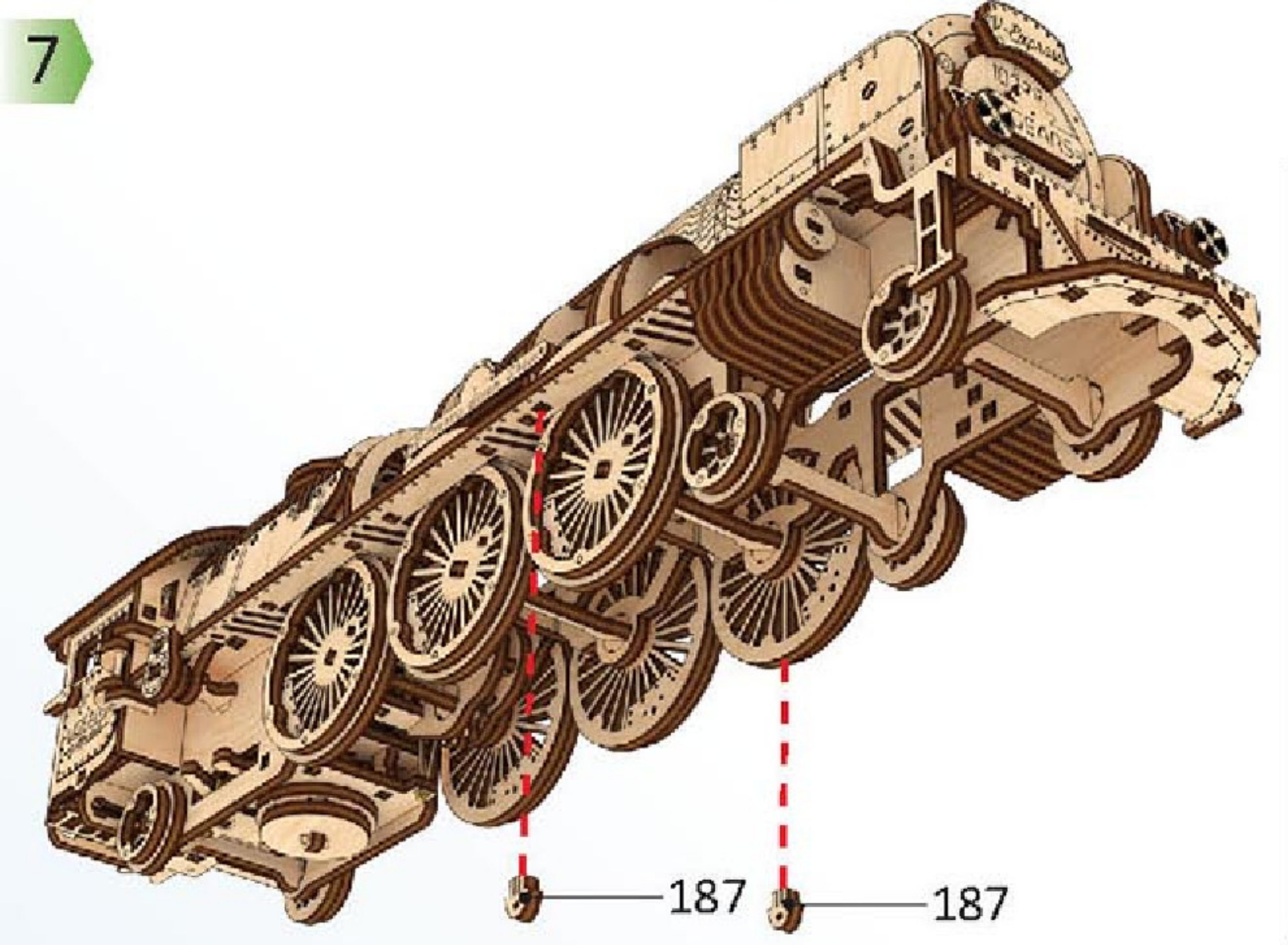
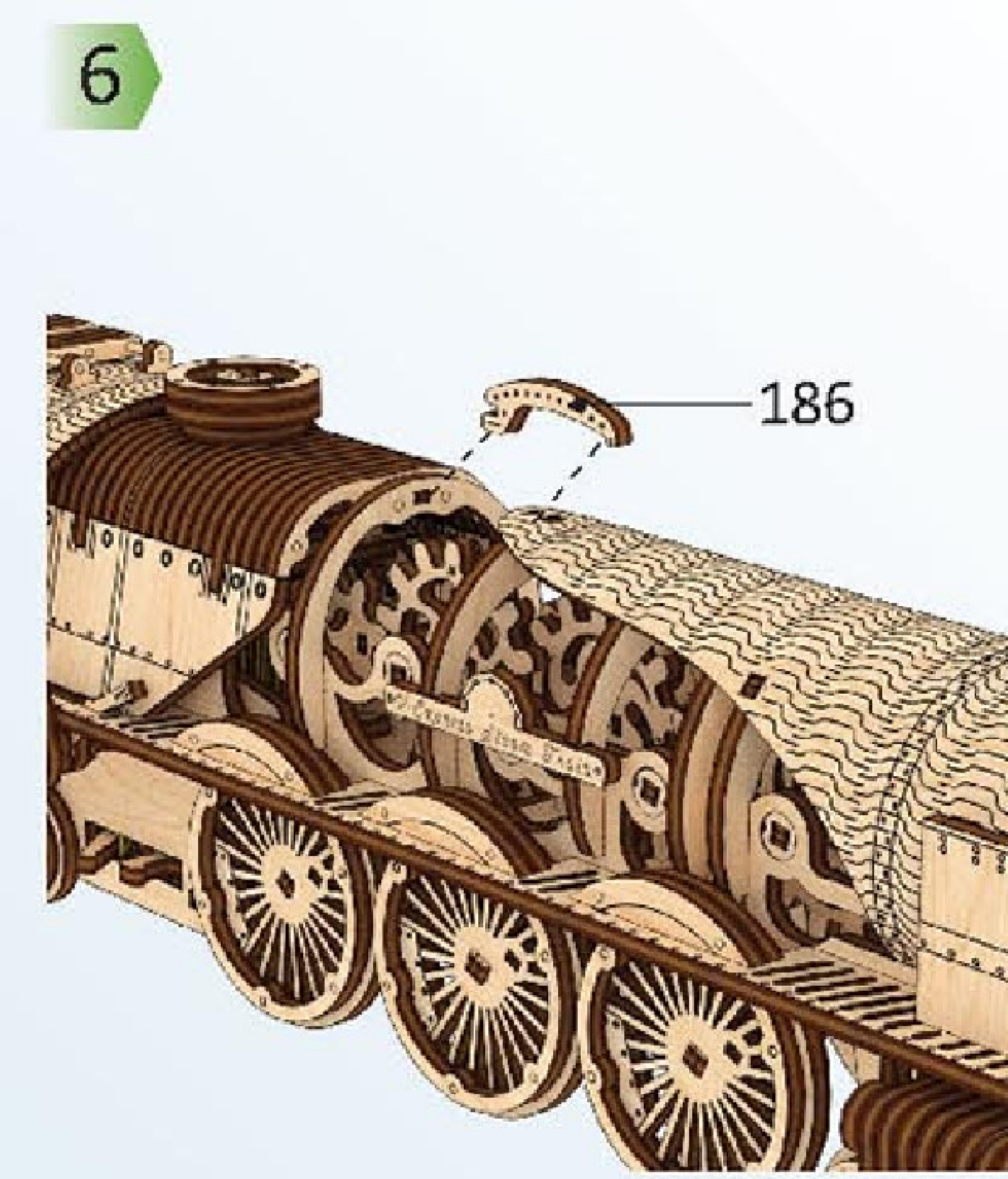
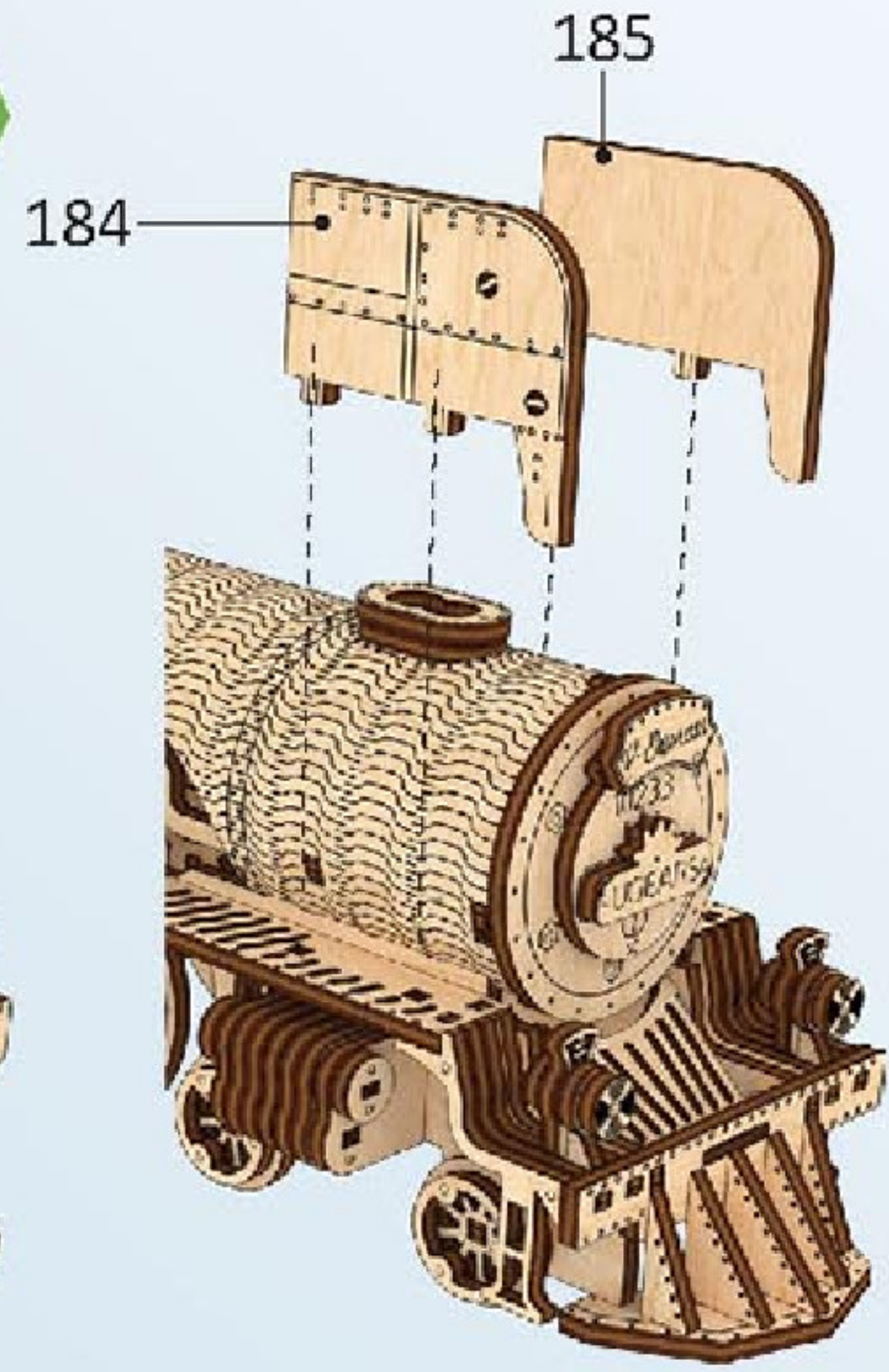
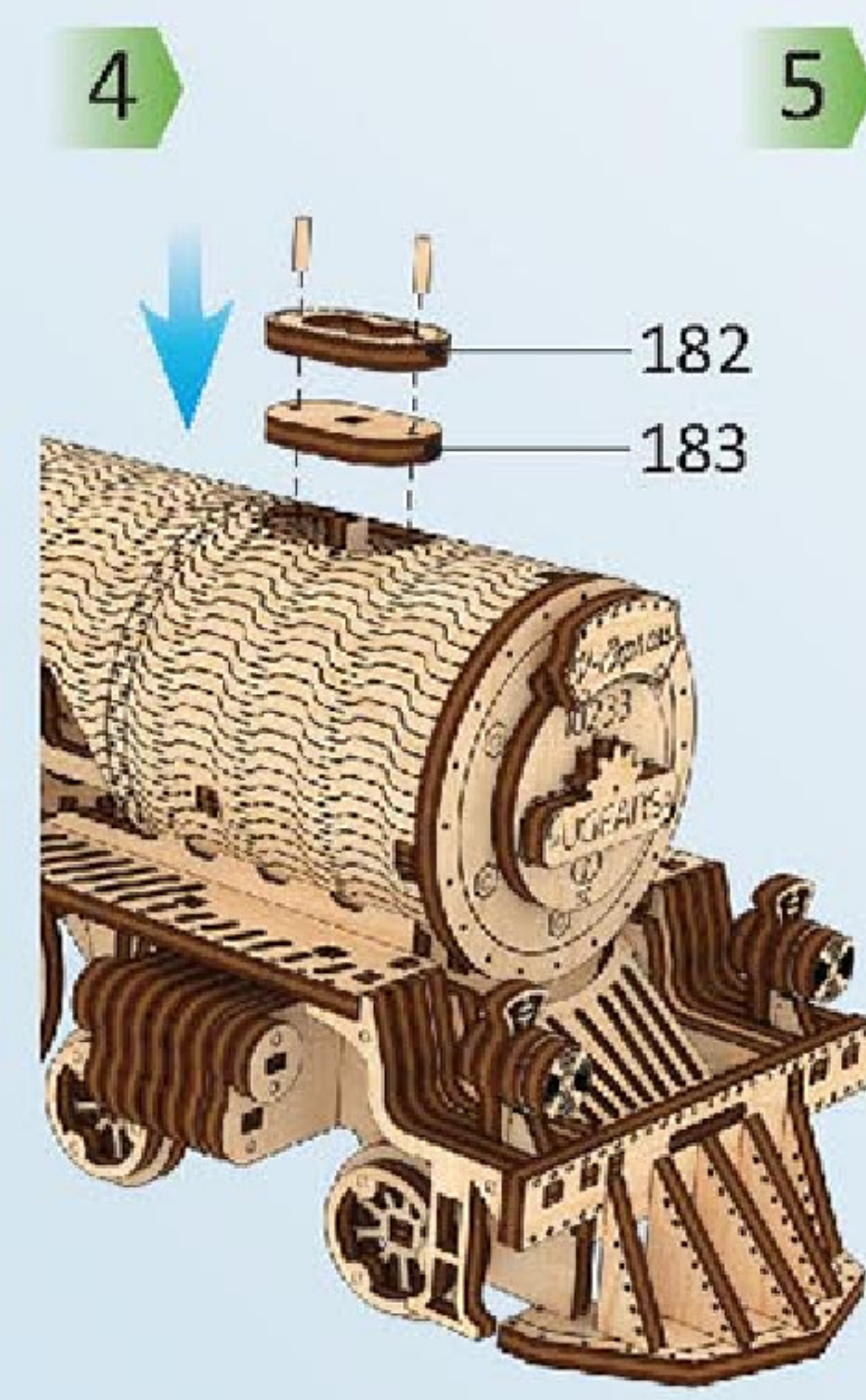
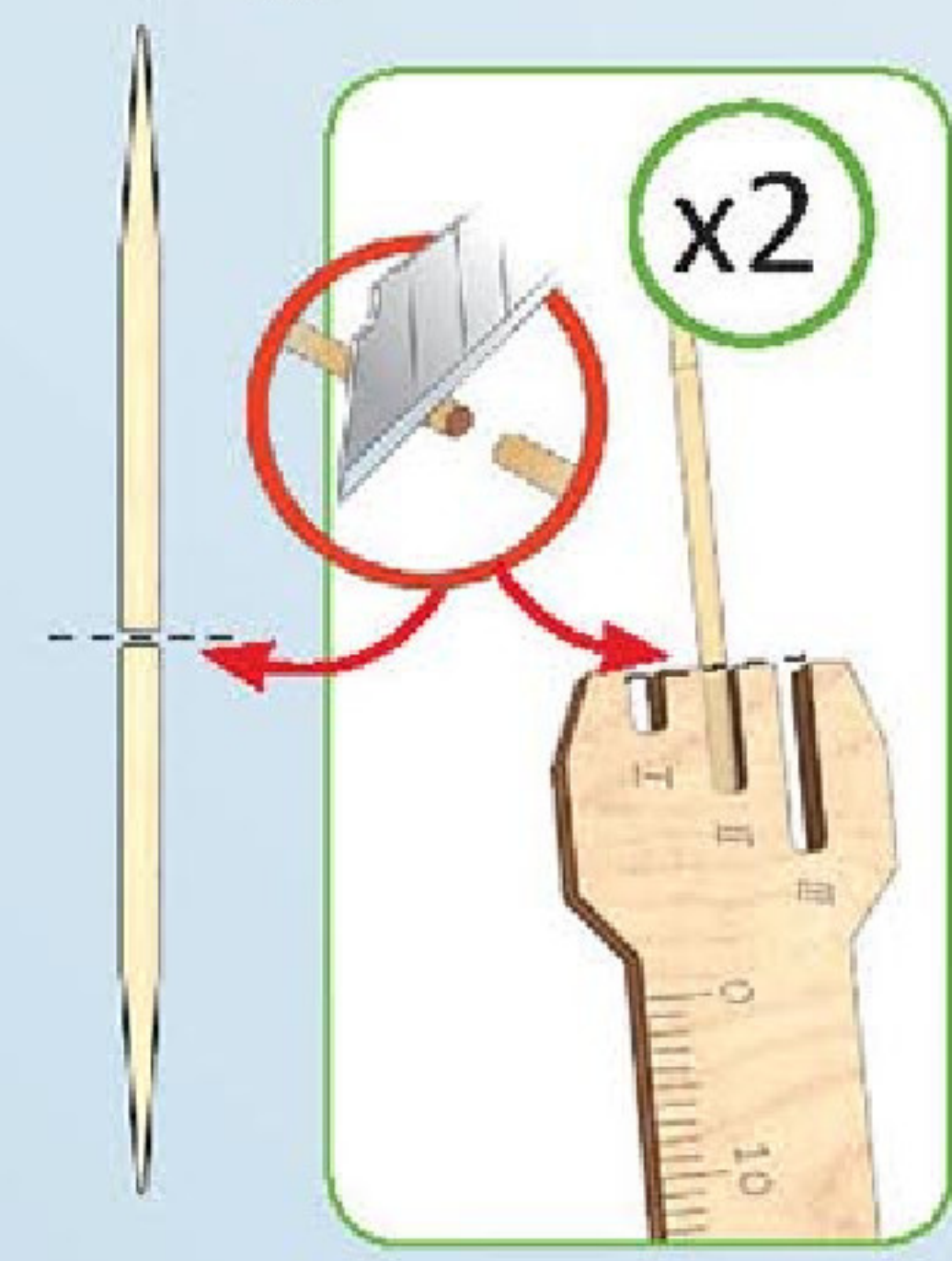
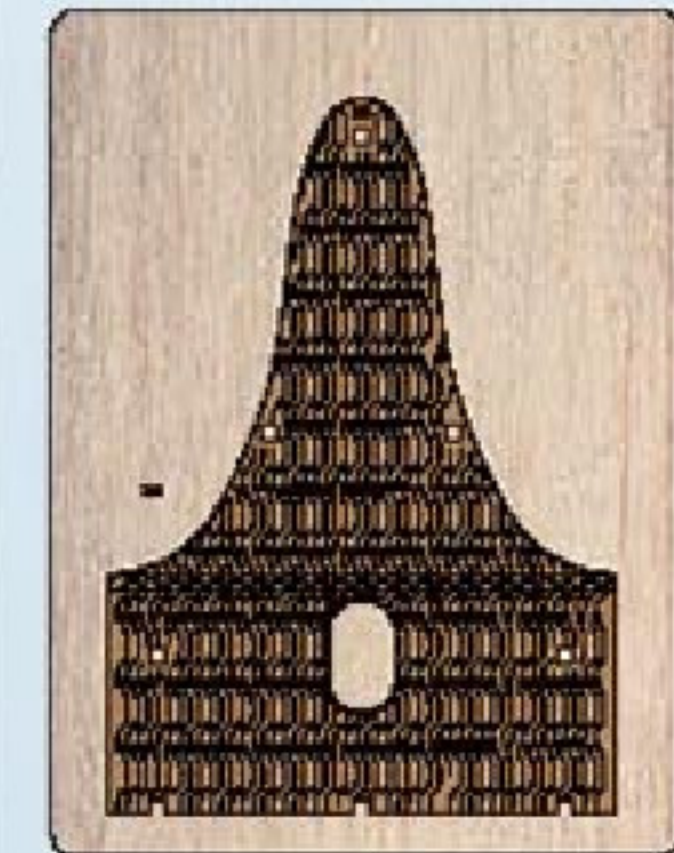
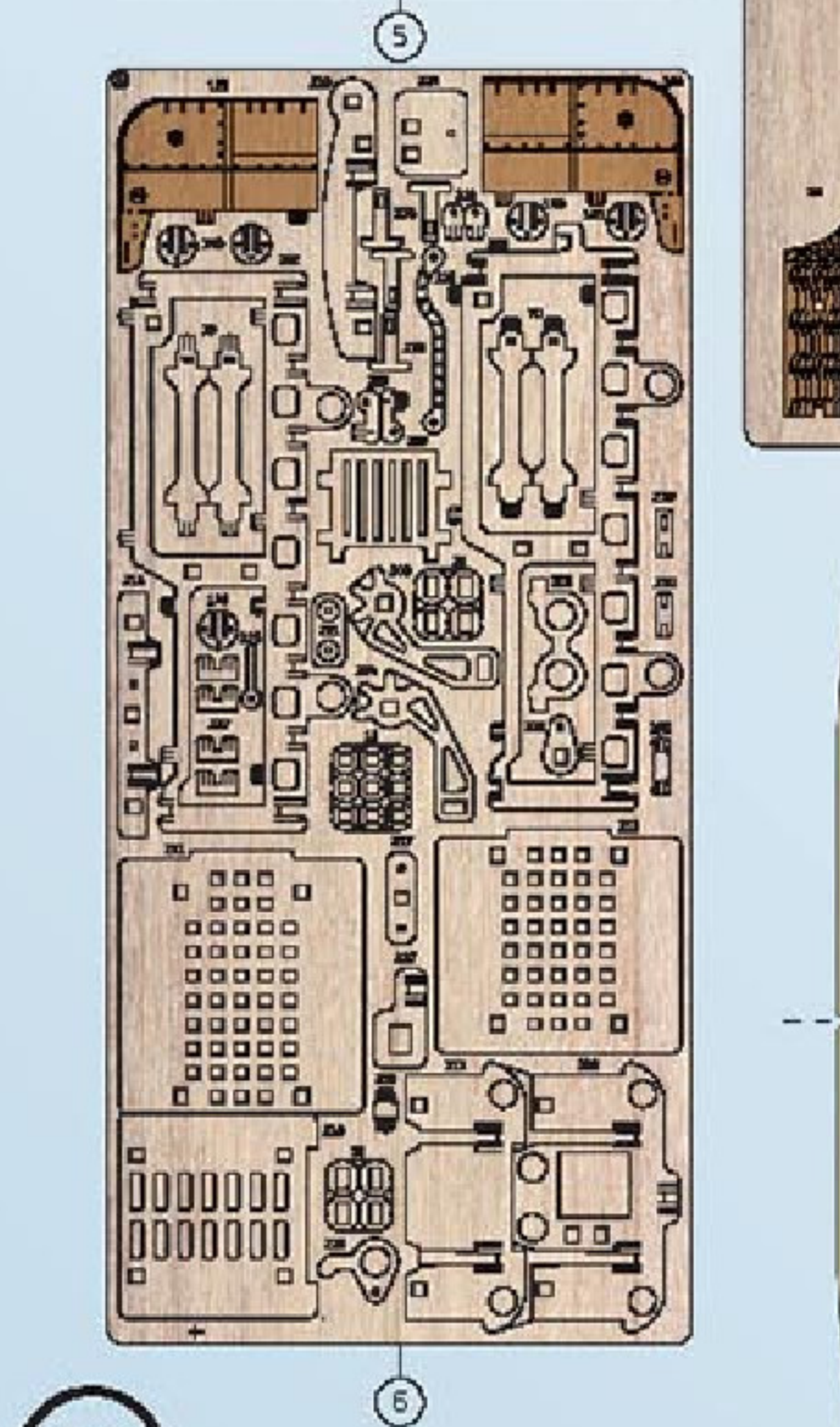
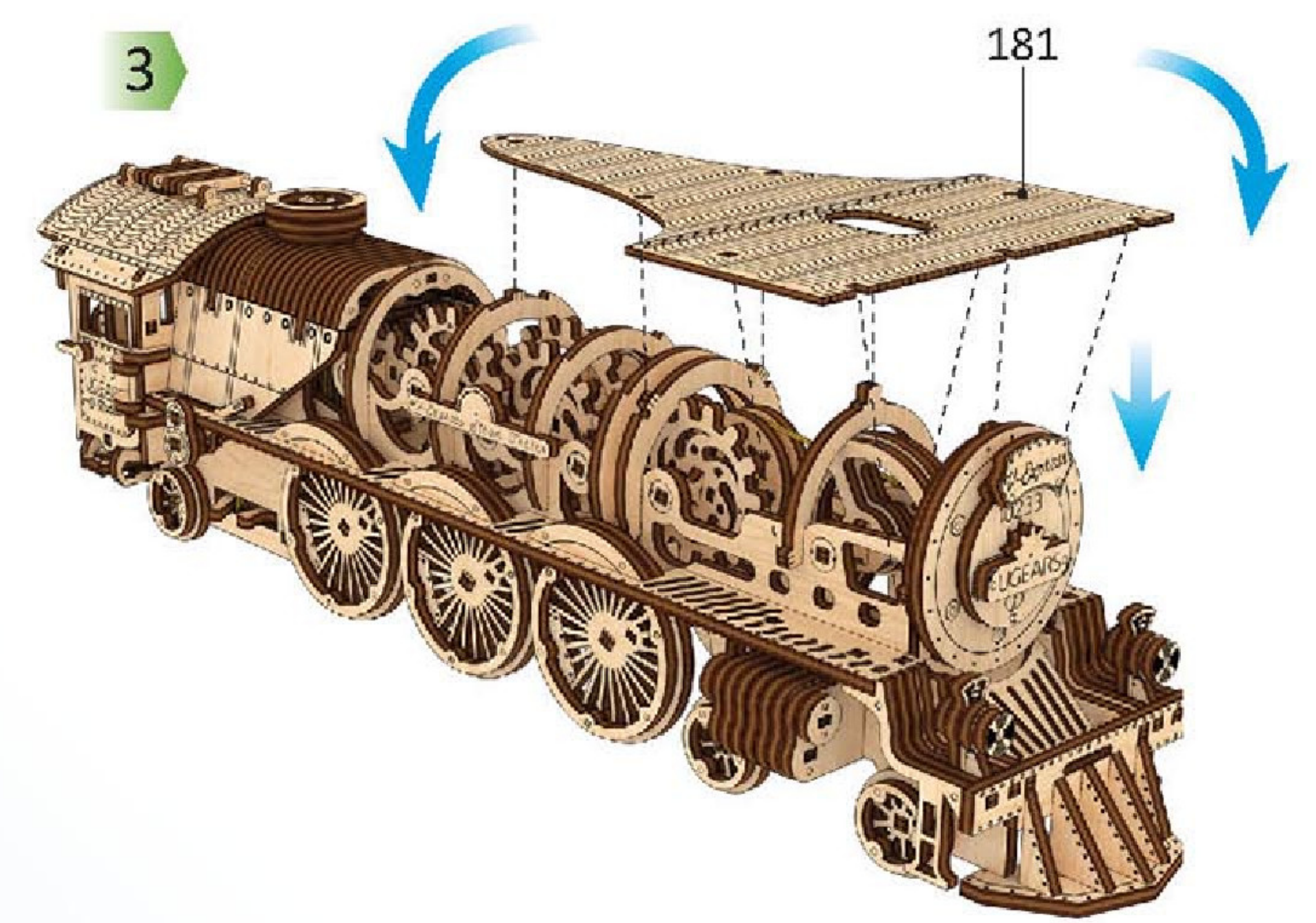
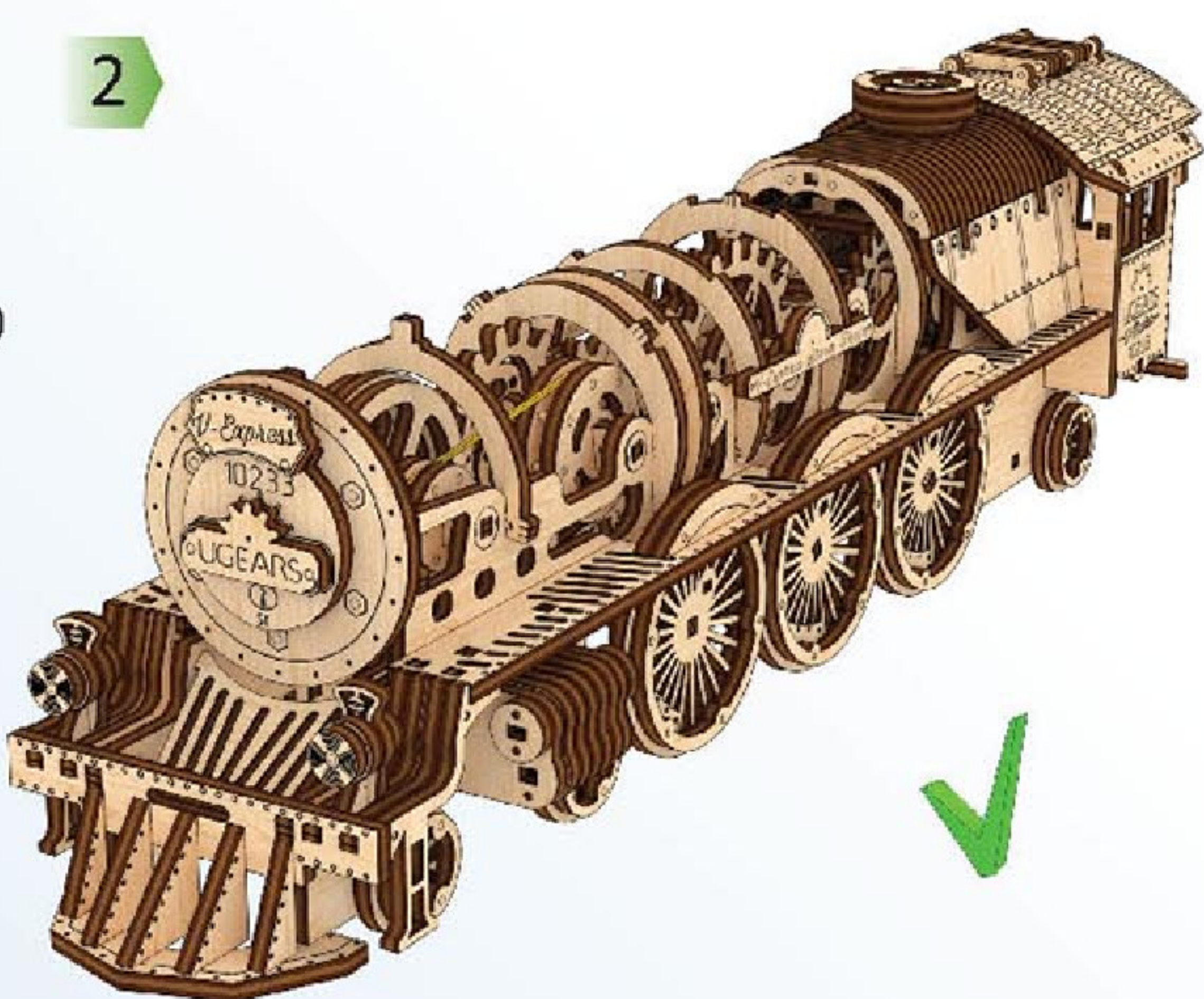
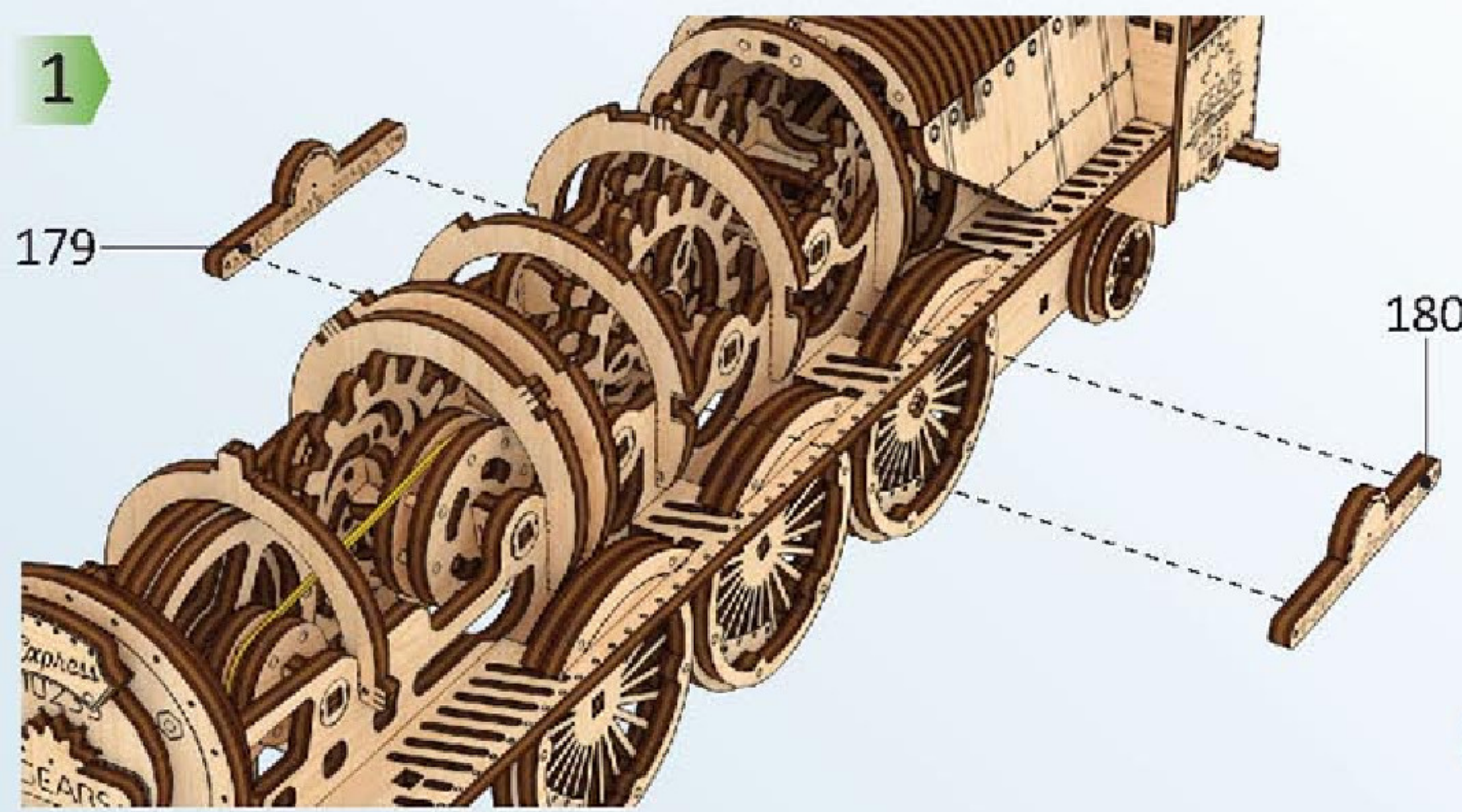
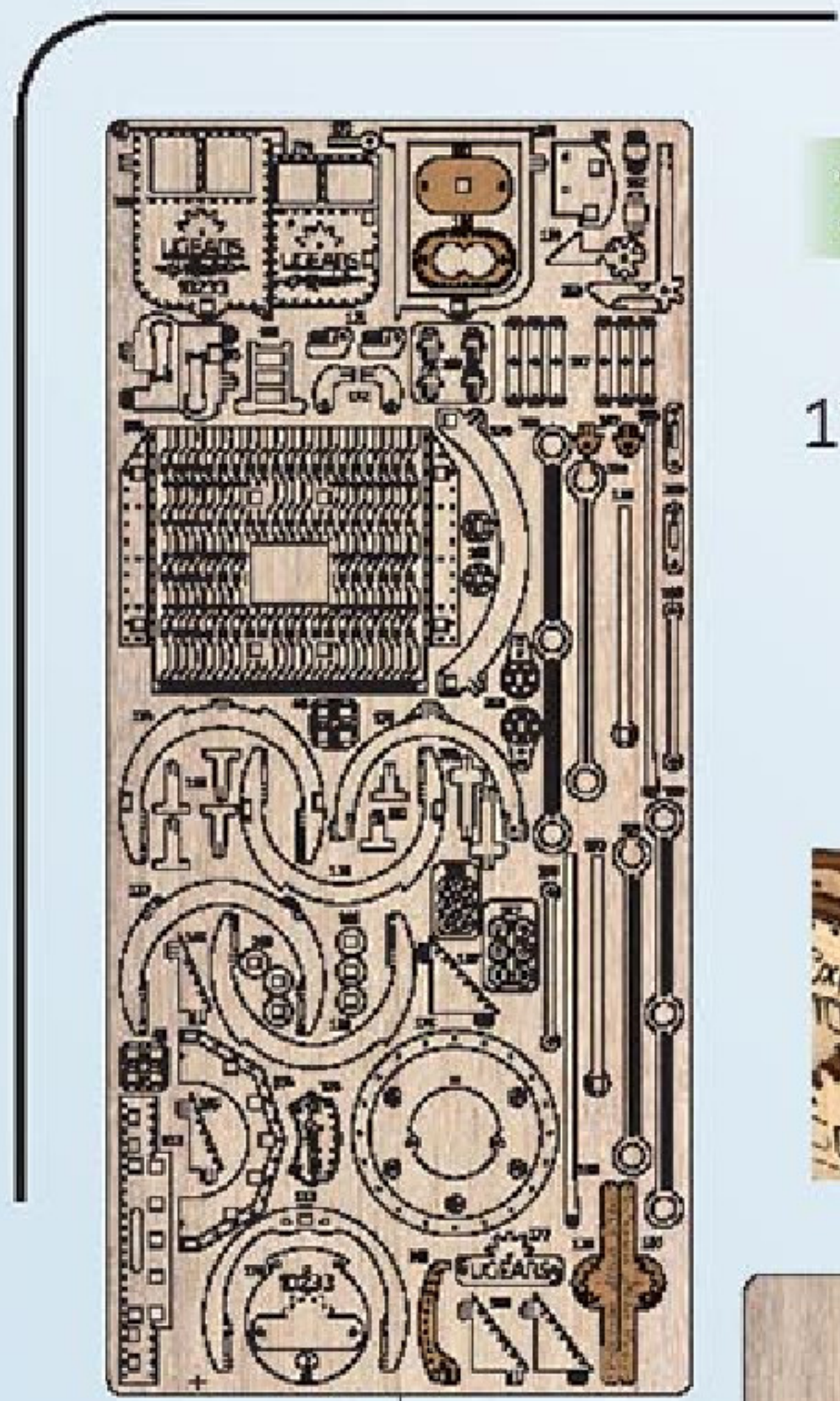

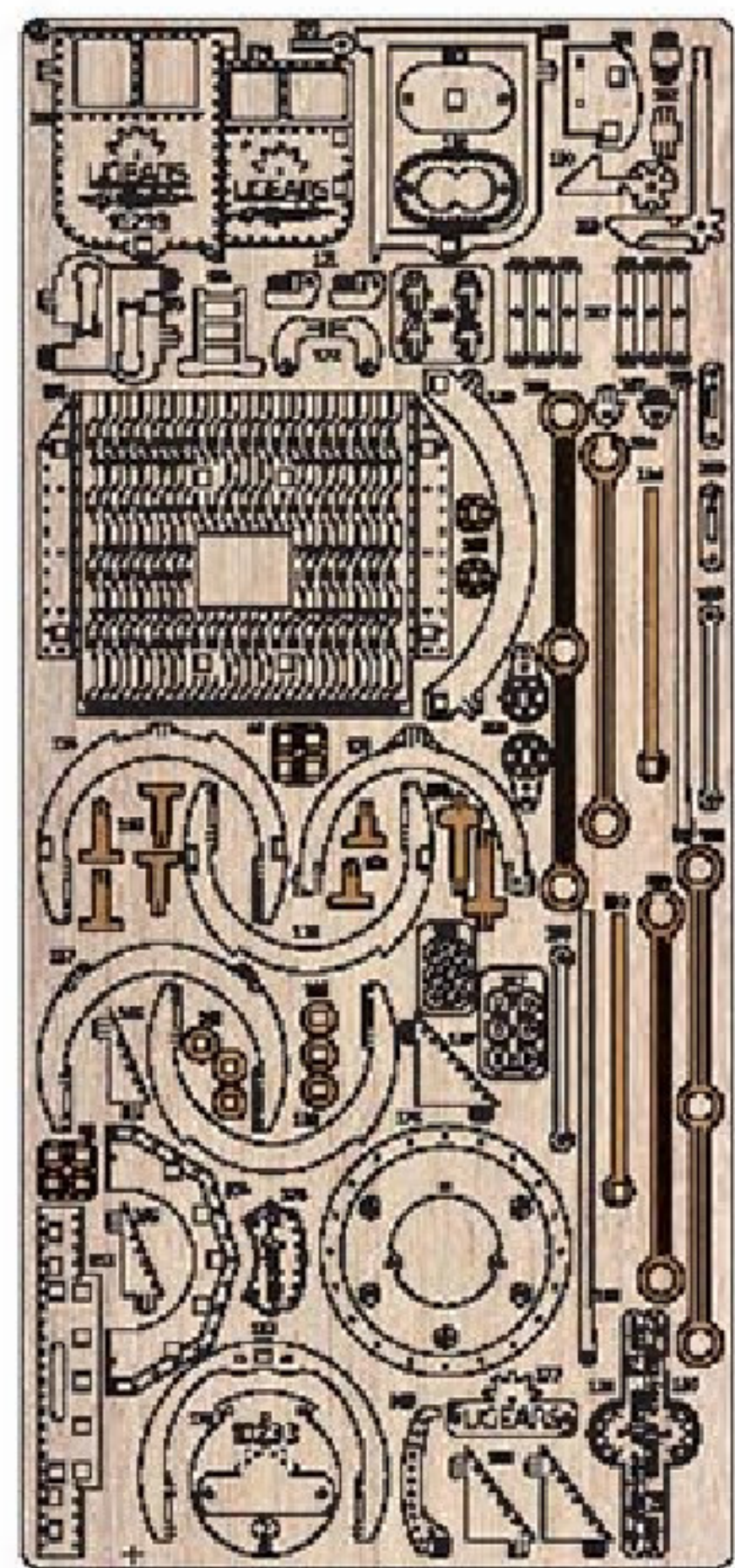

1

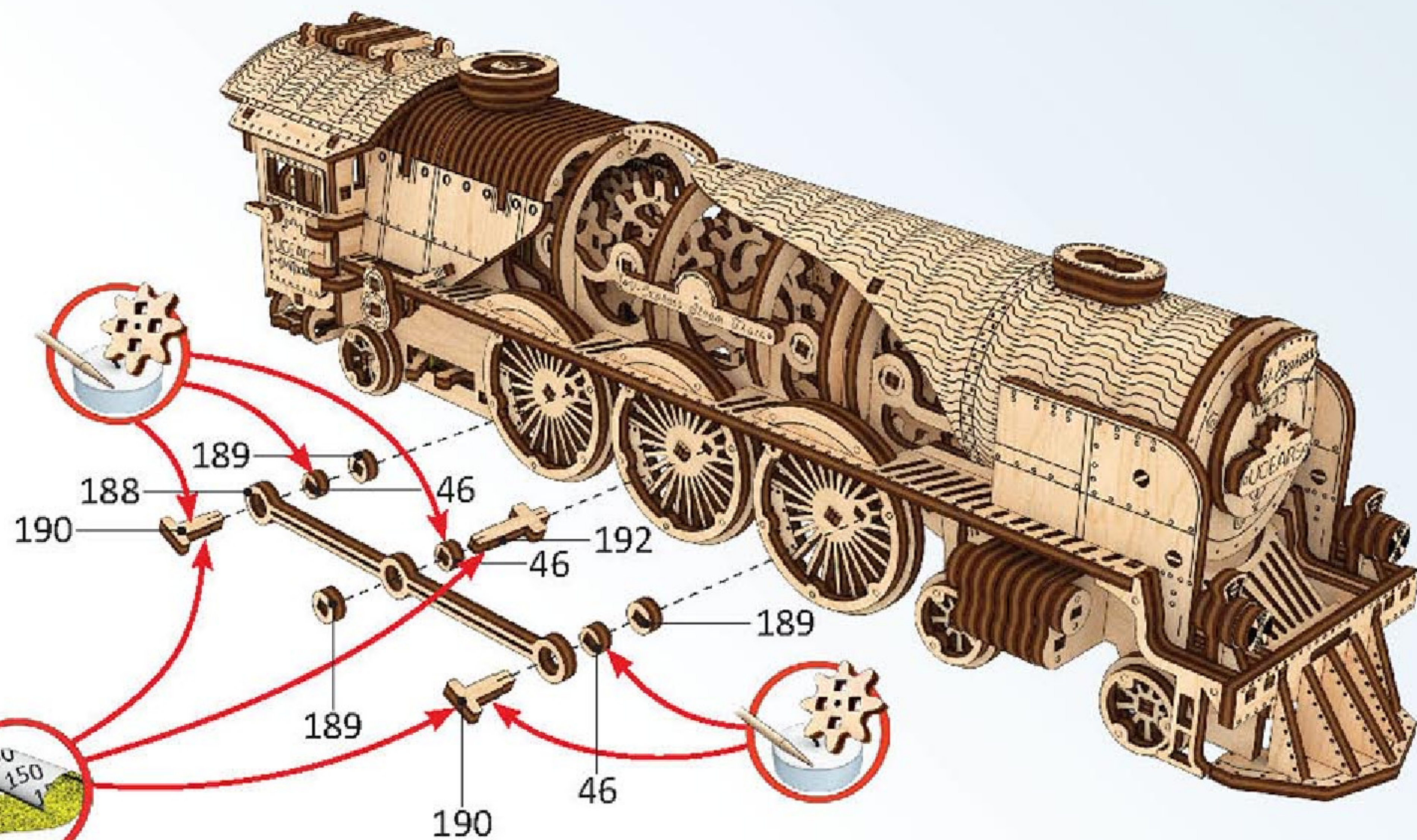

2

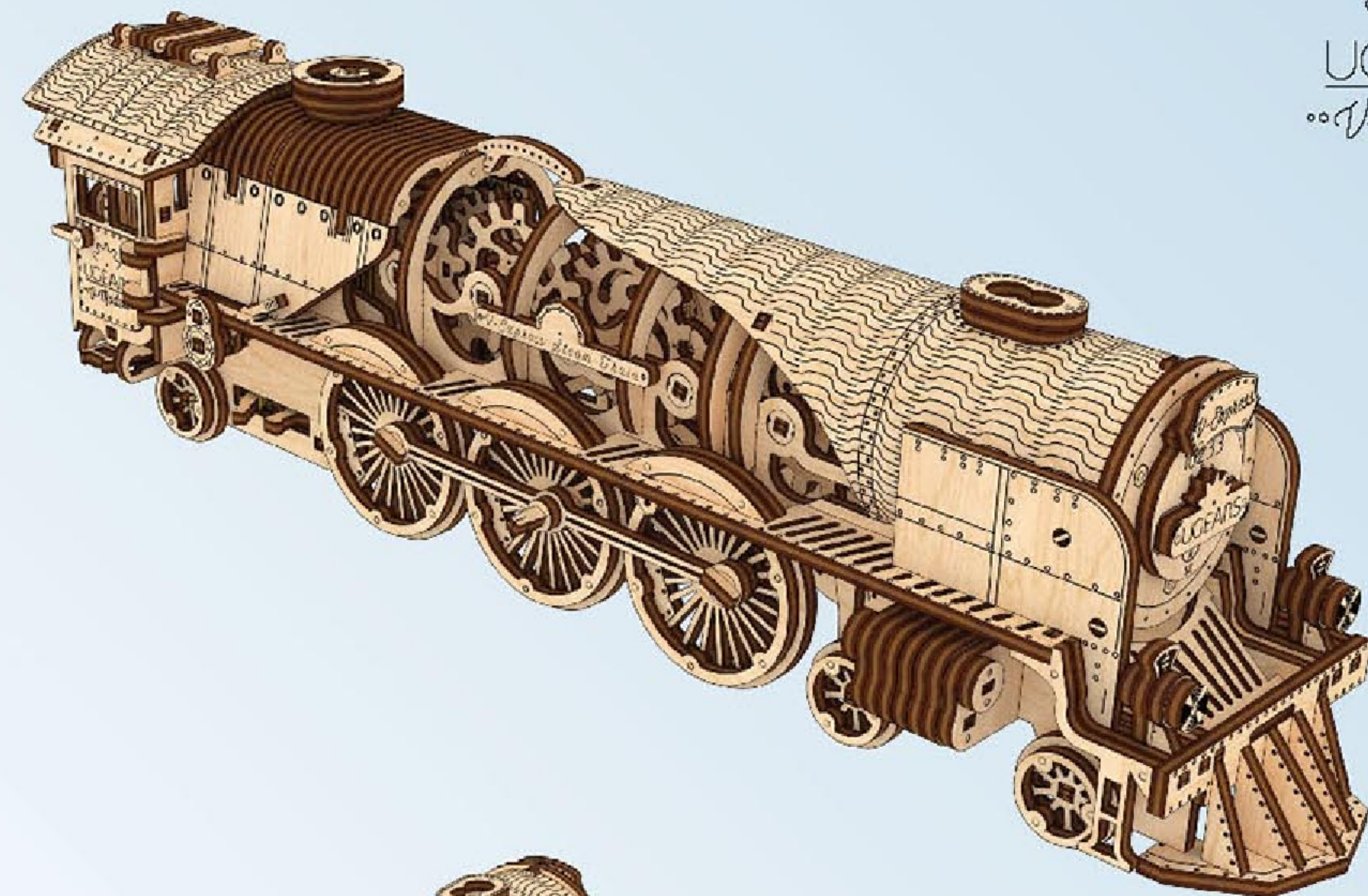

3

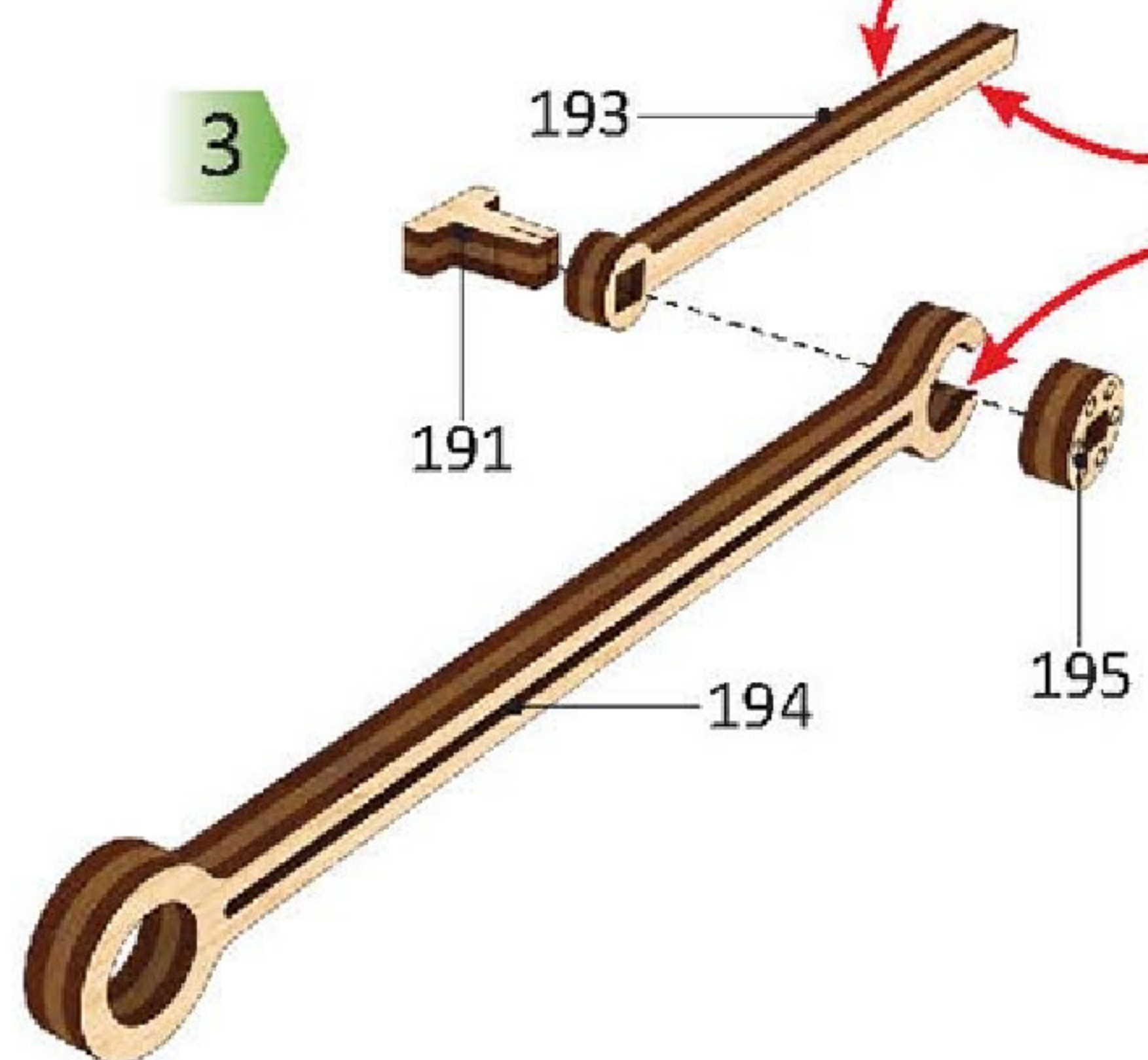

4

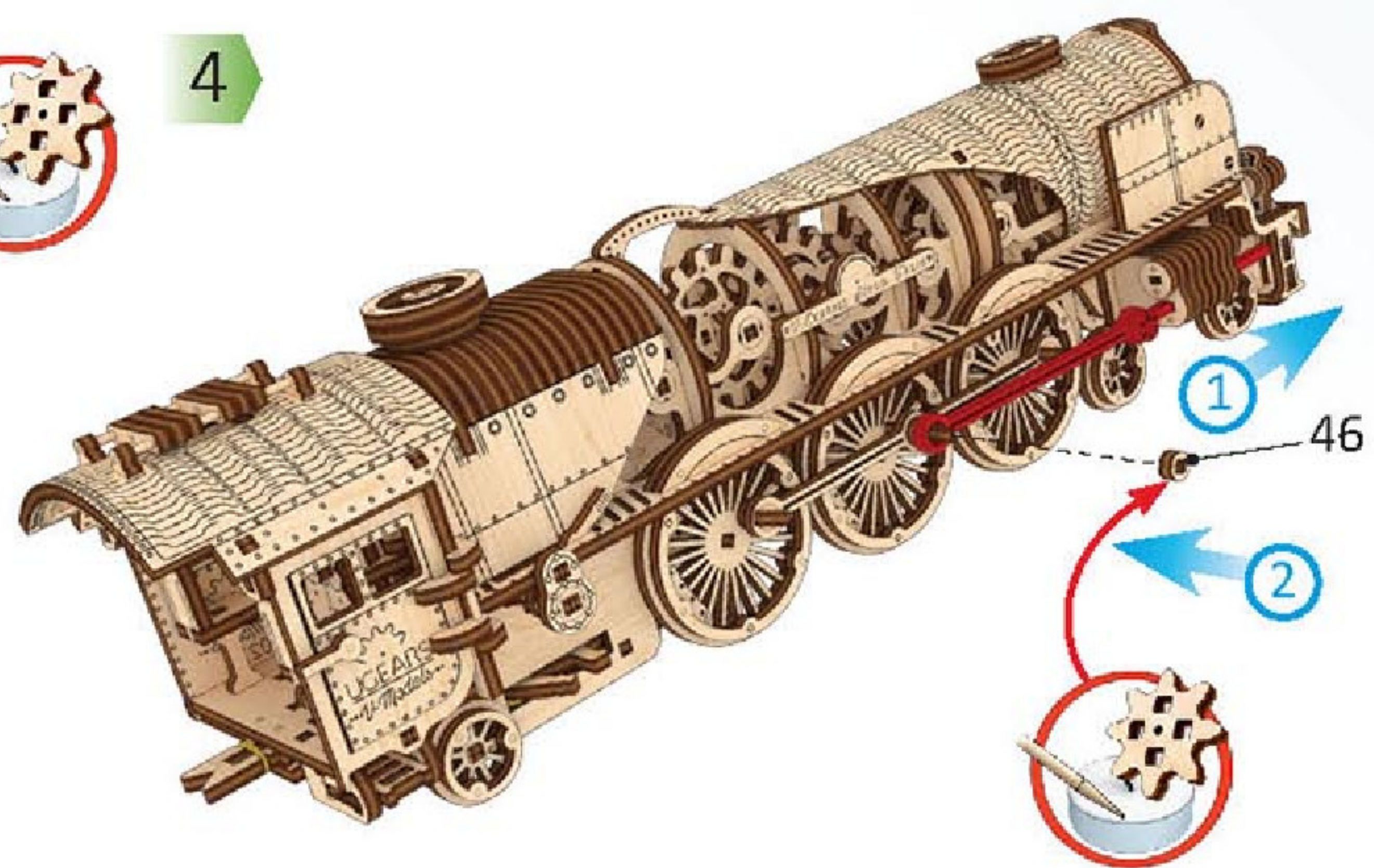

5

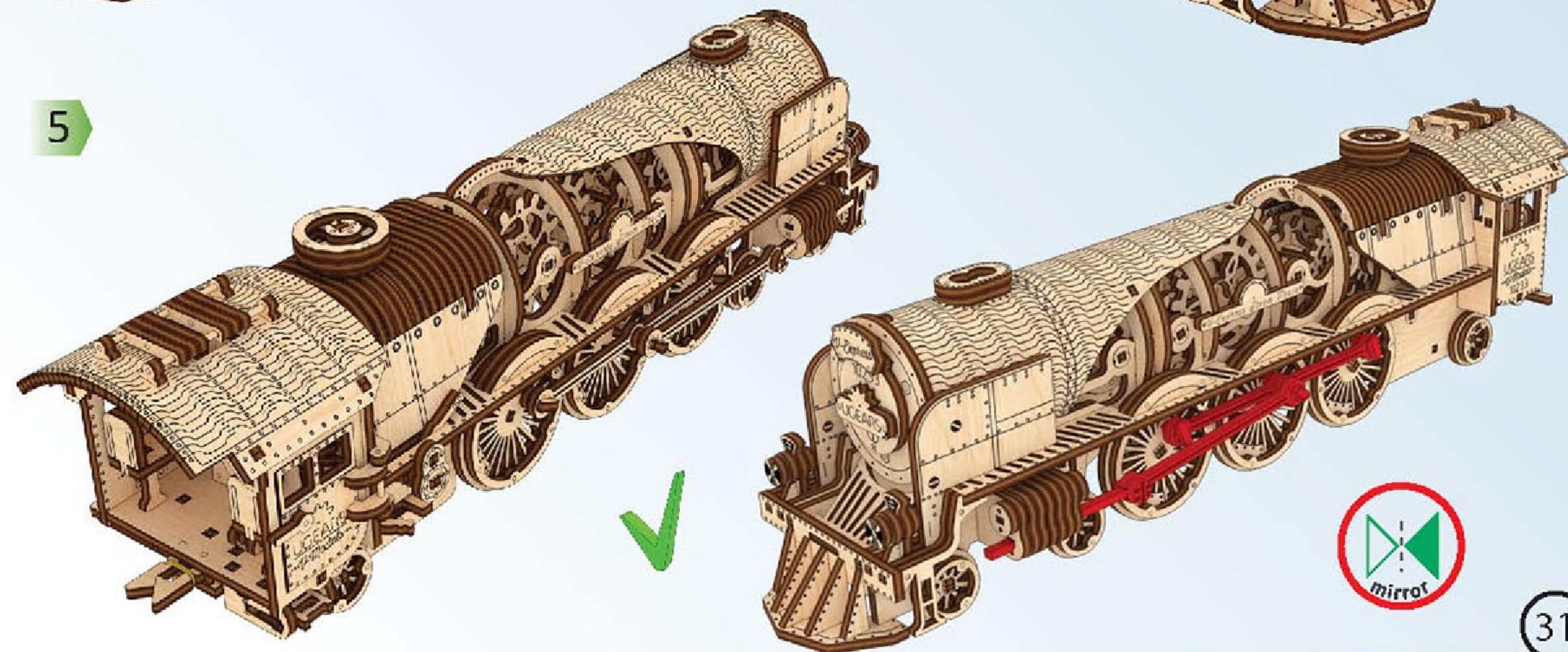

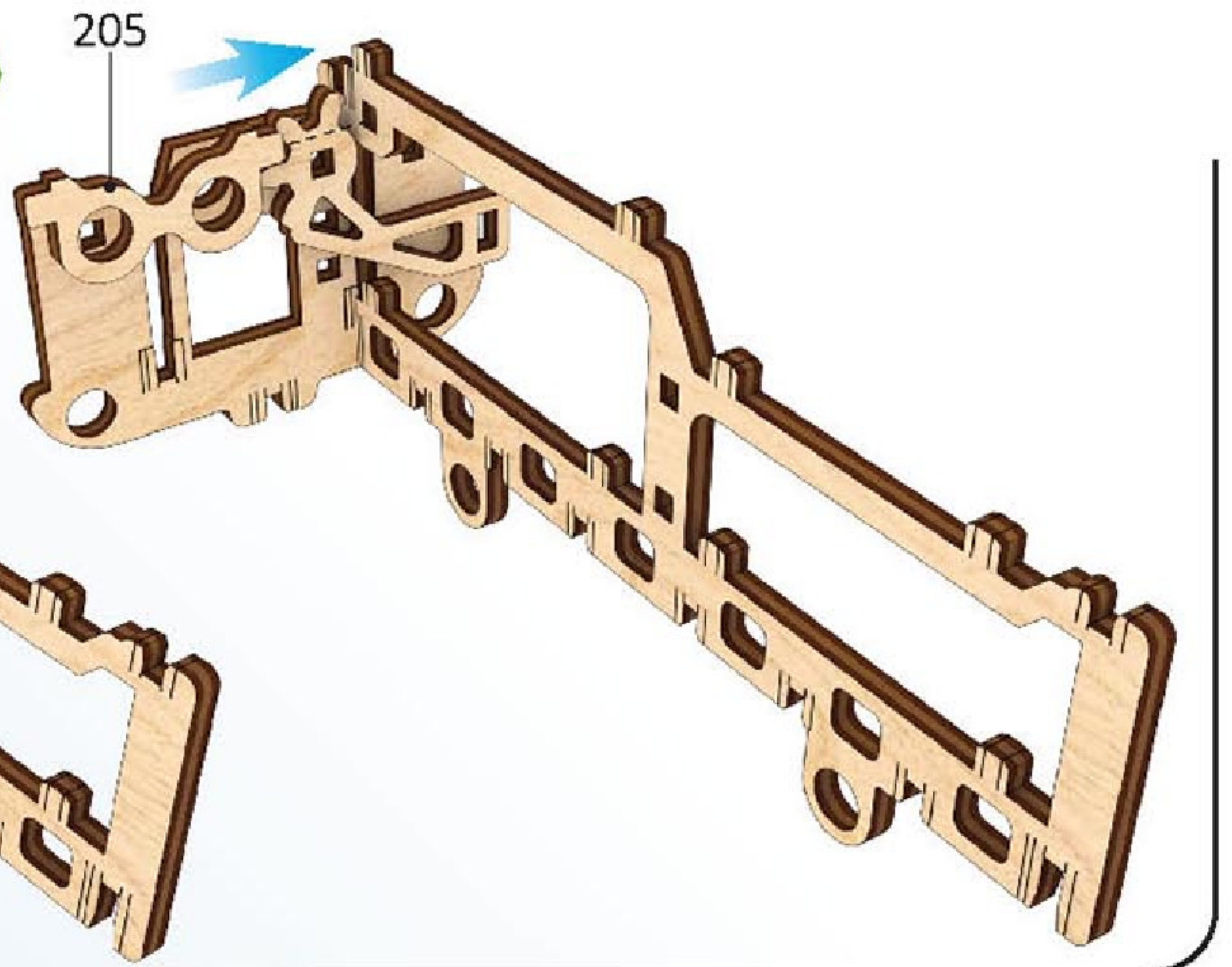
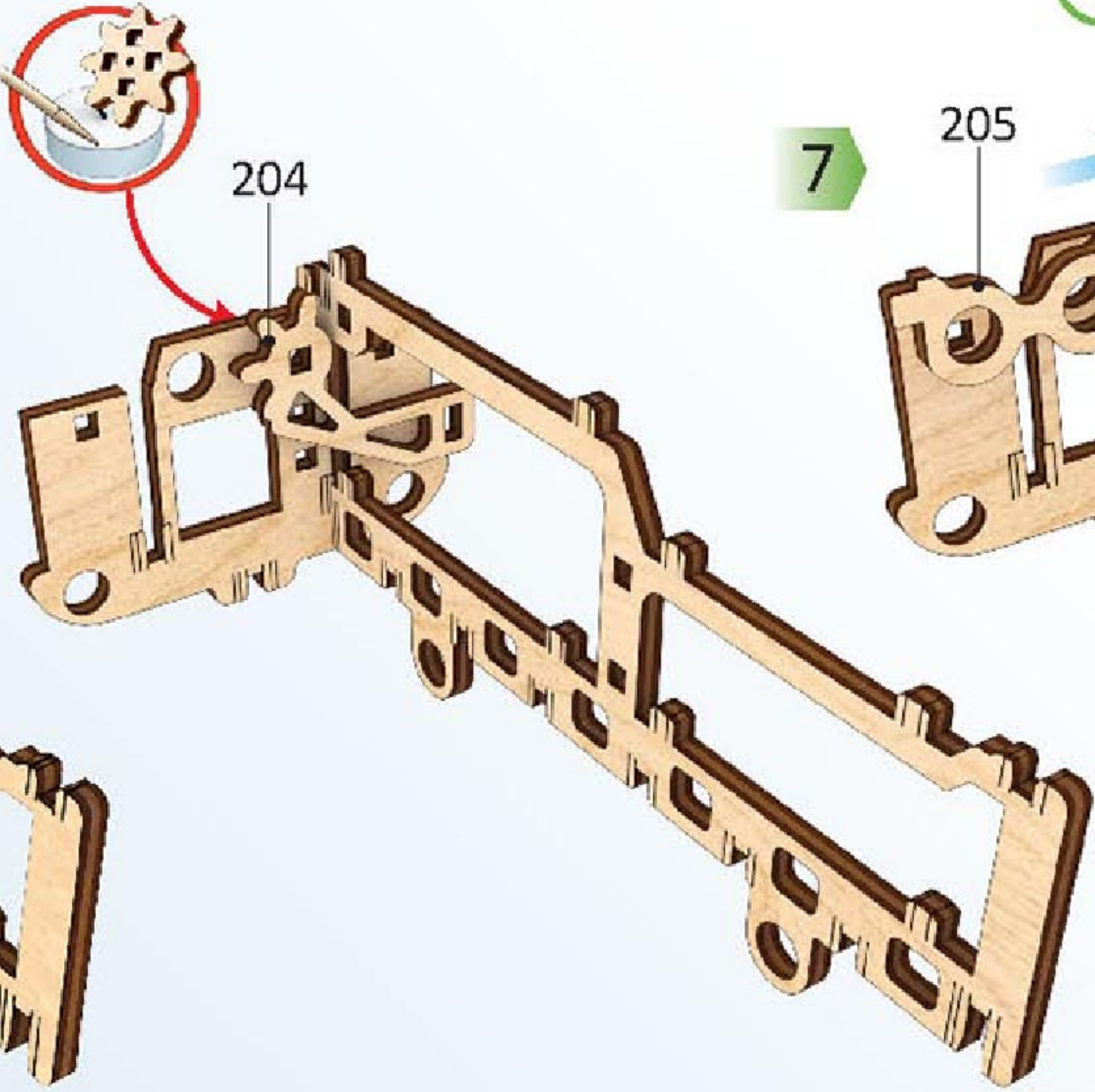
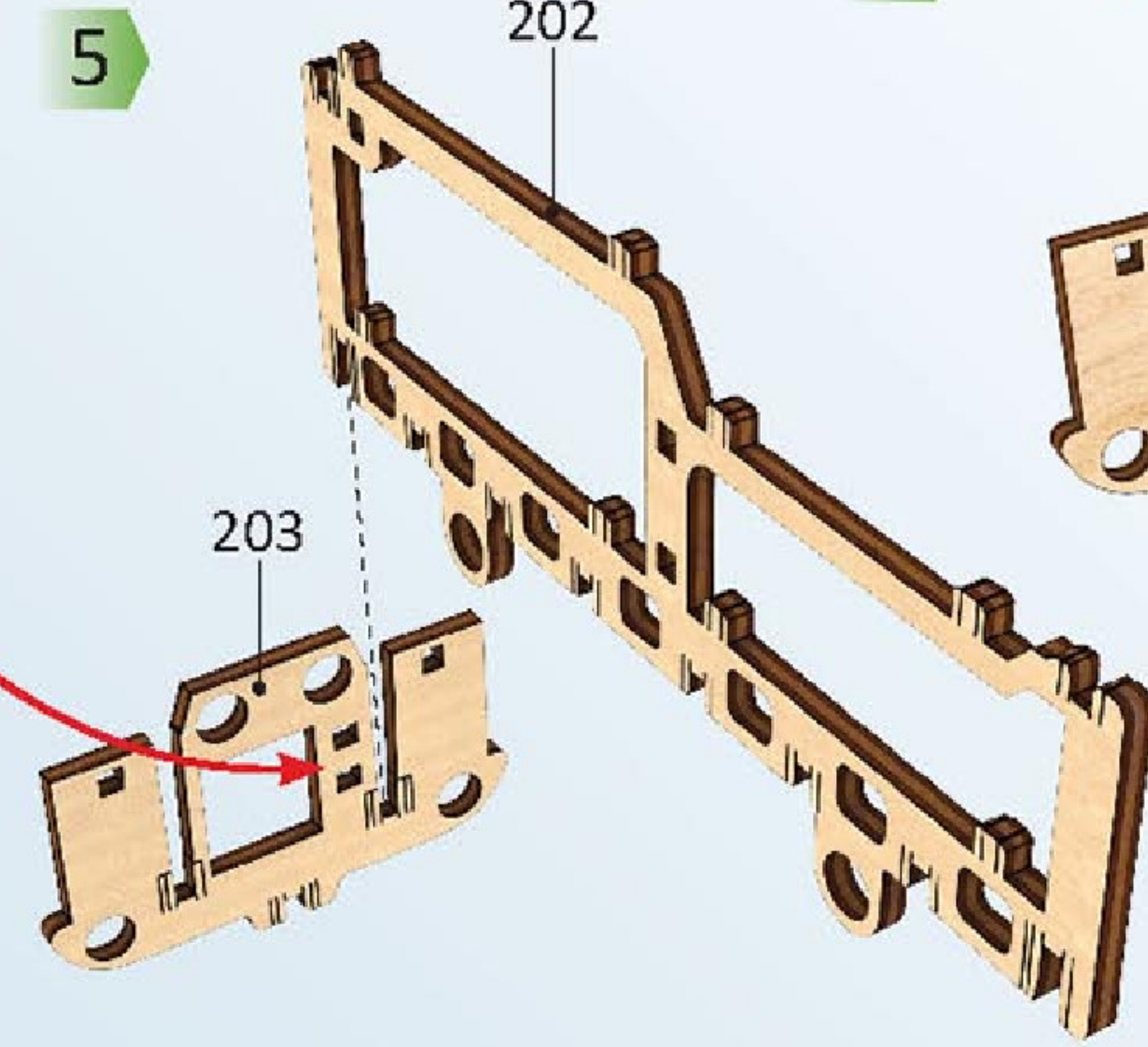
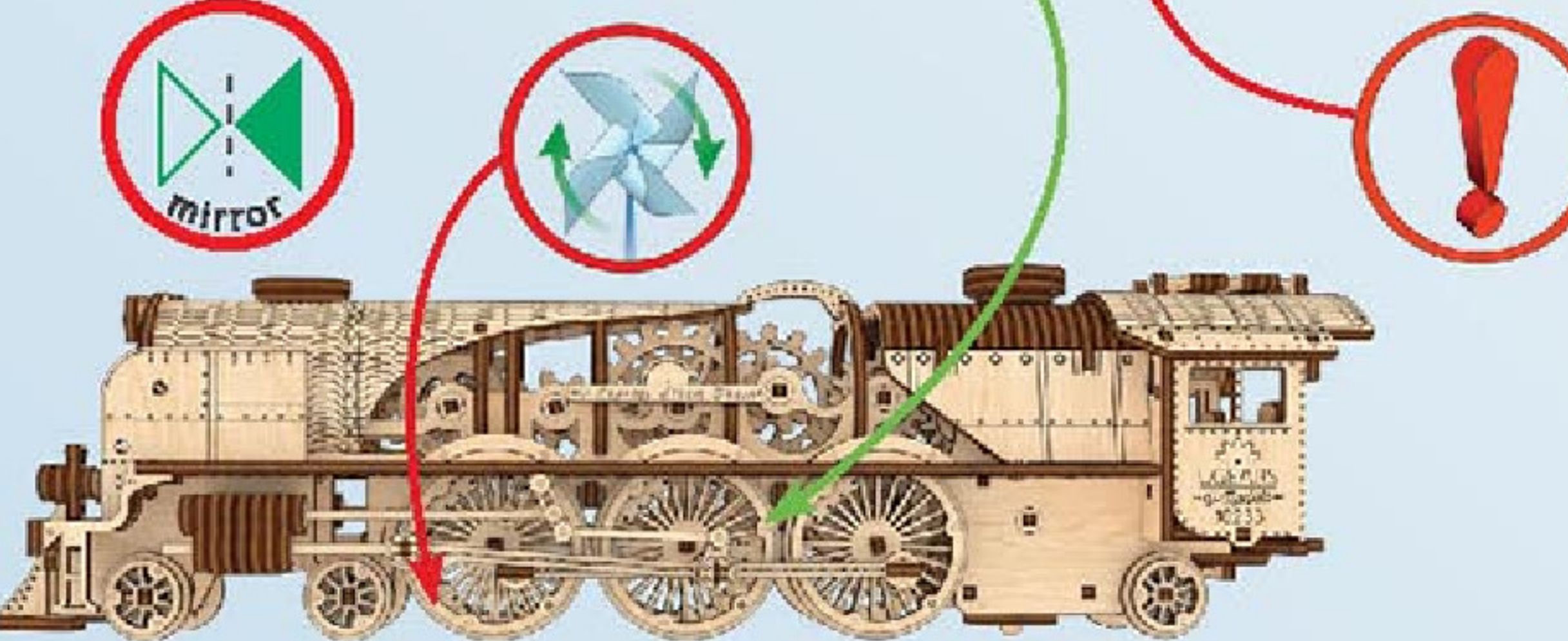
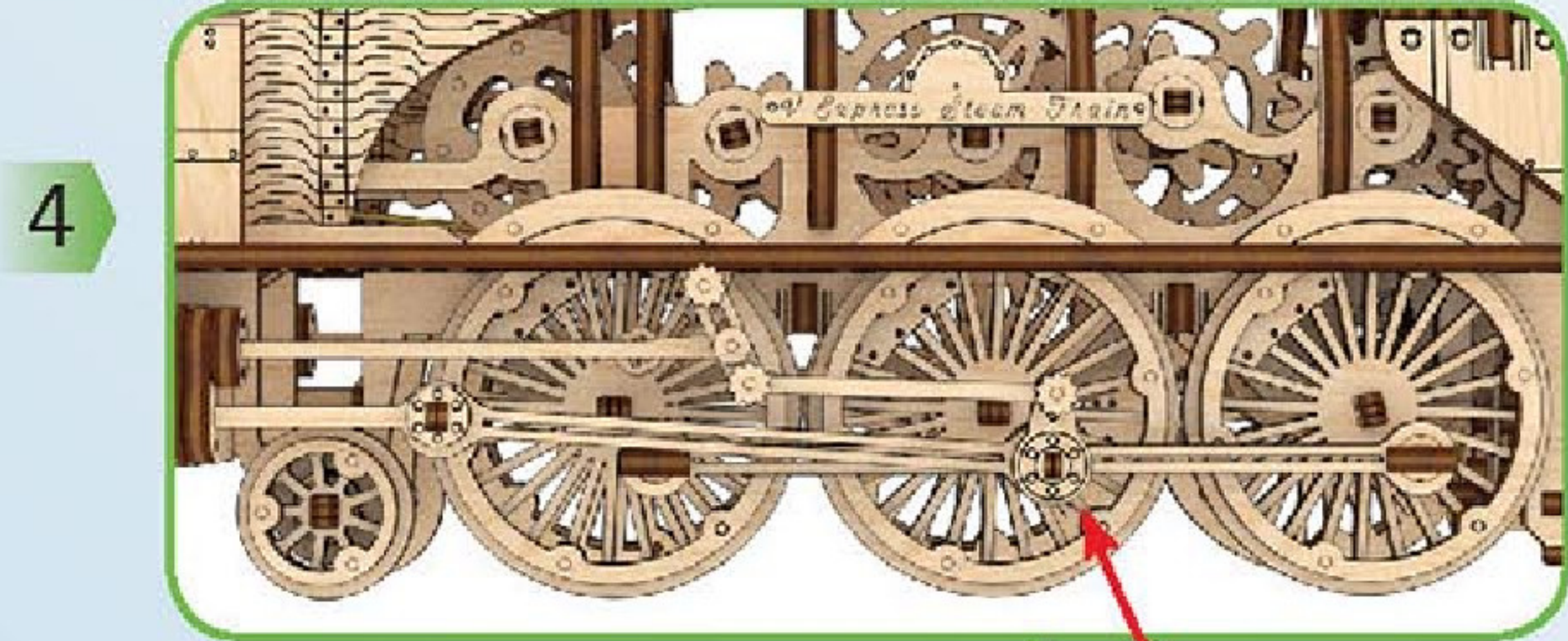
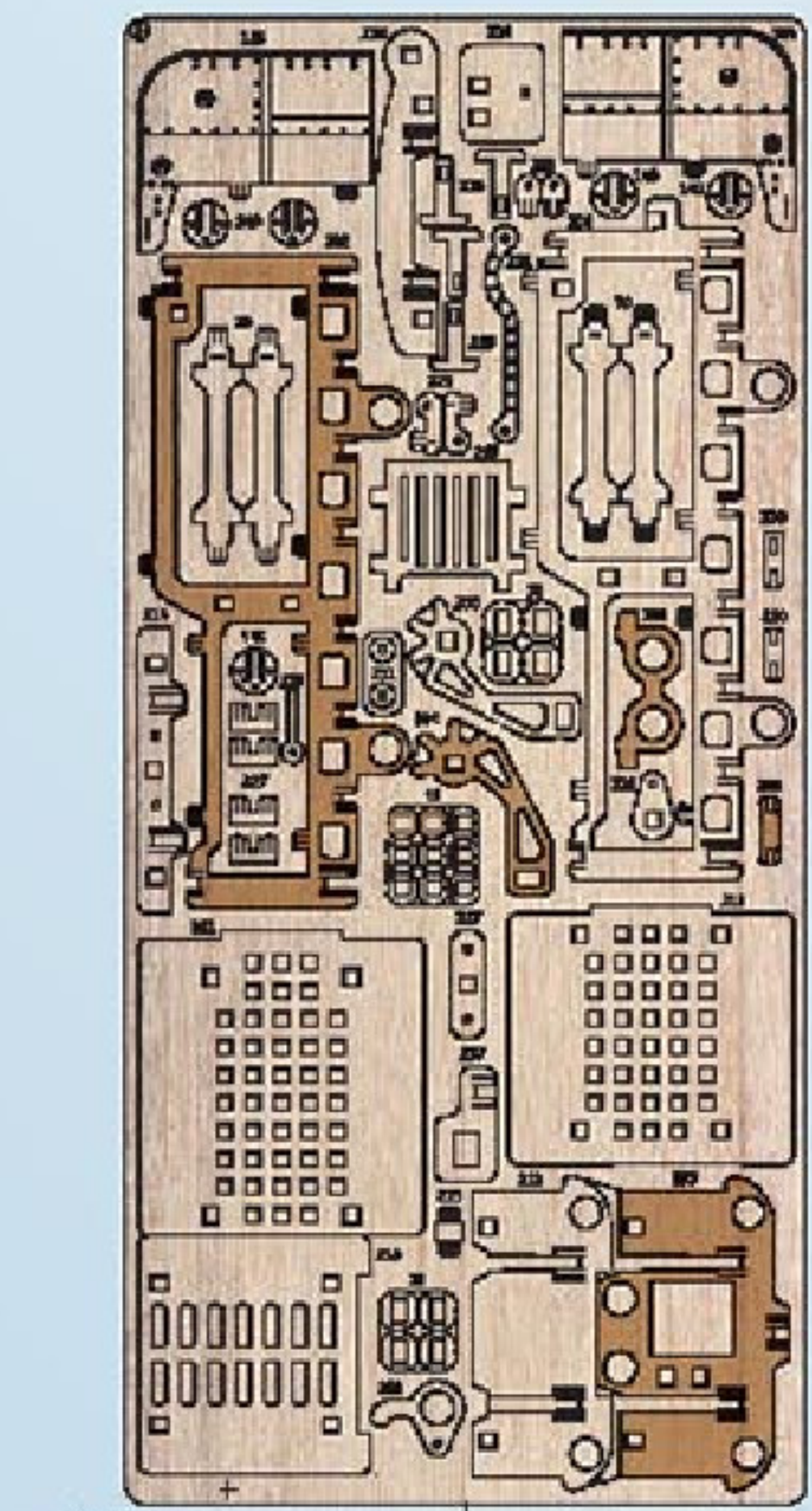
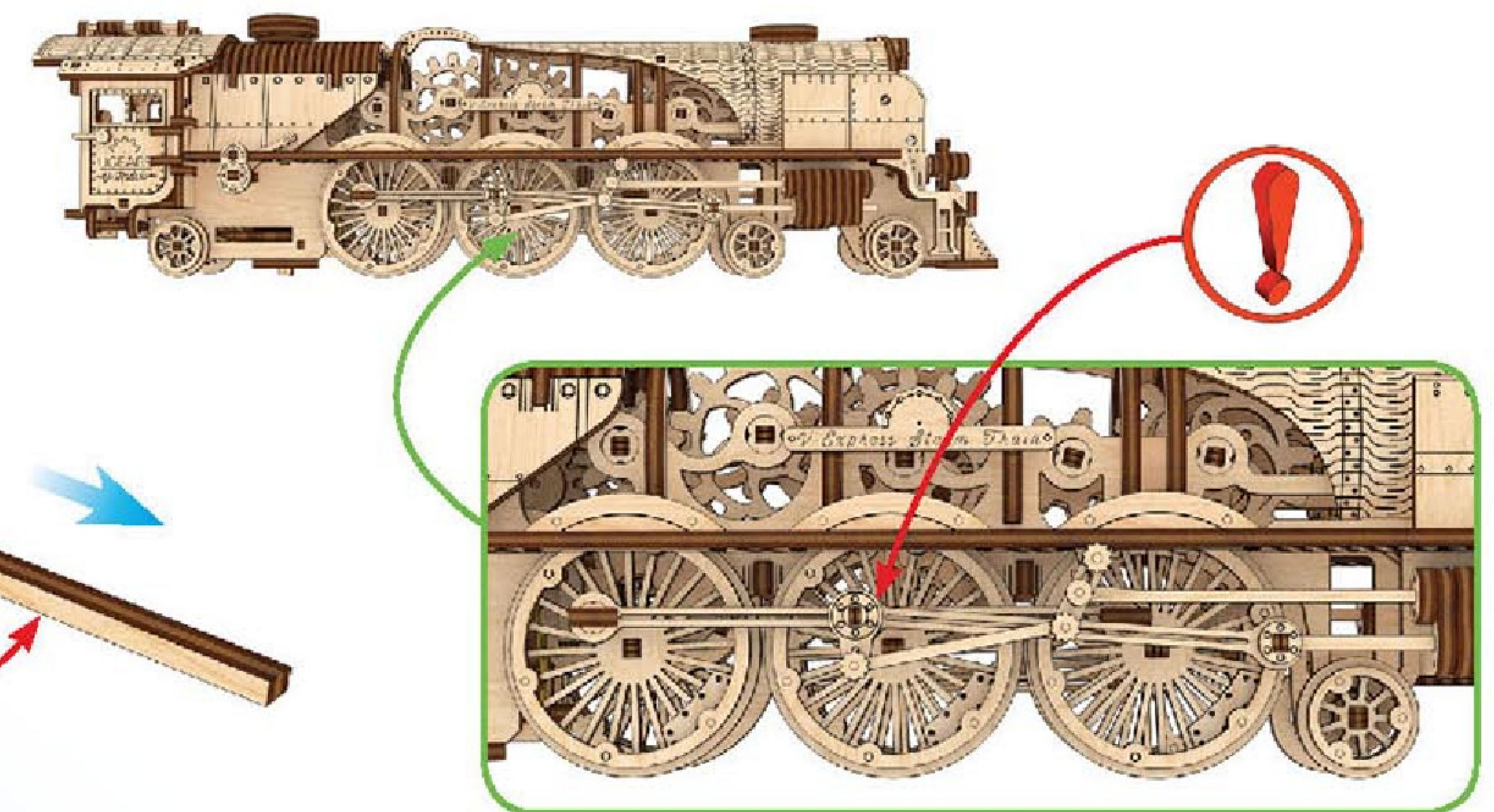
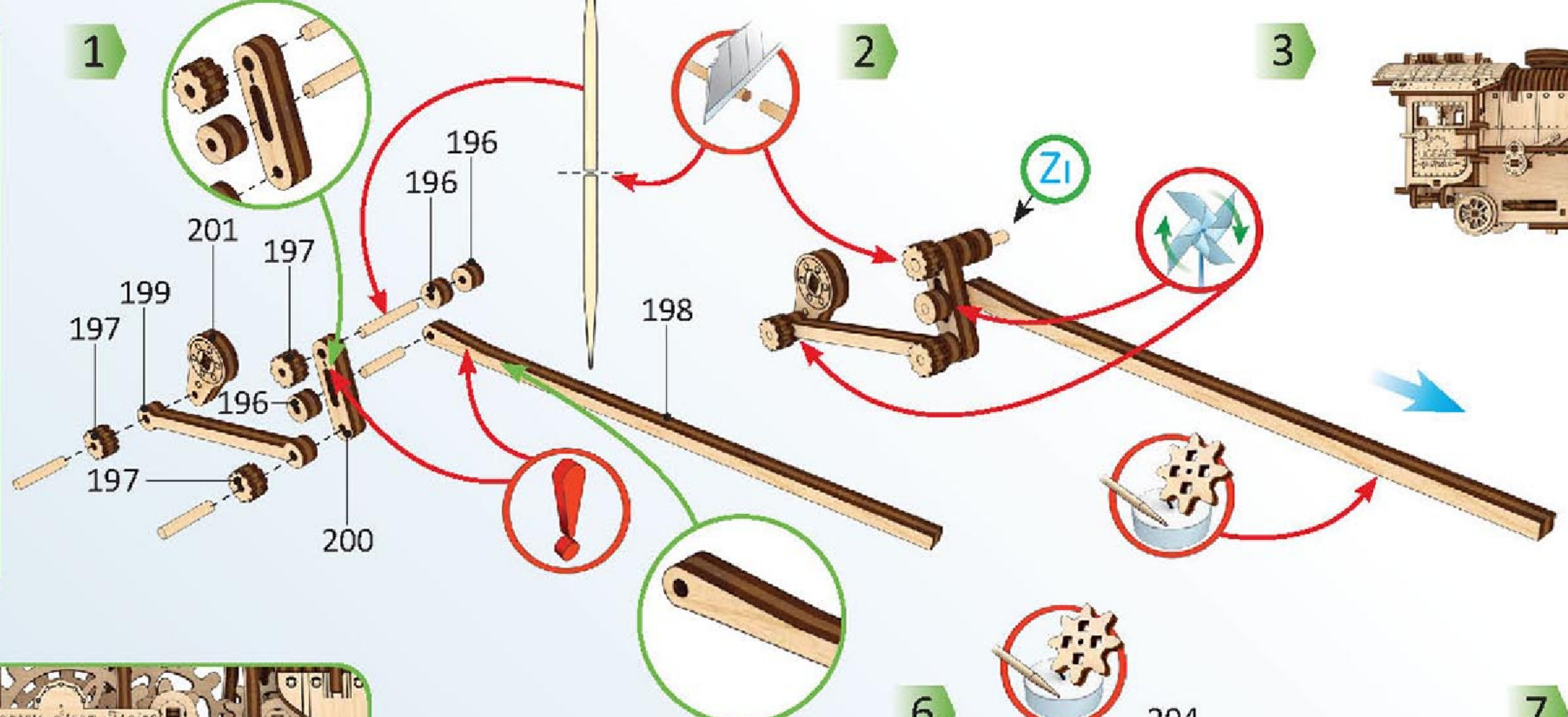
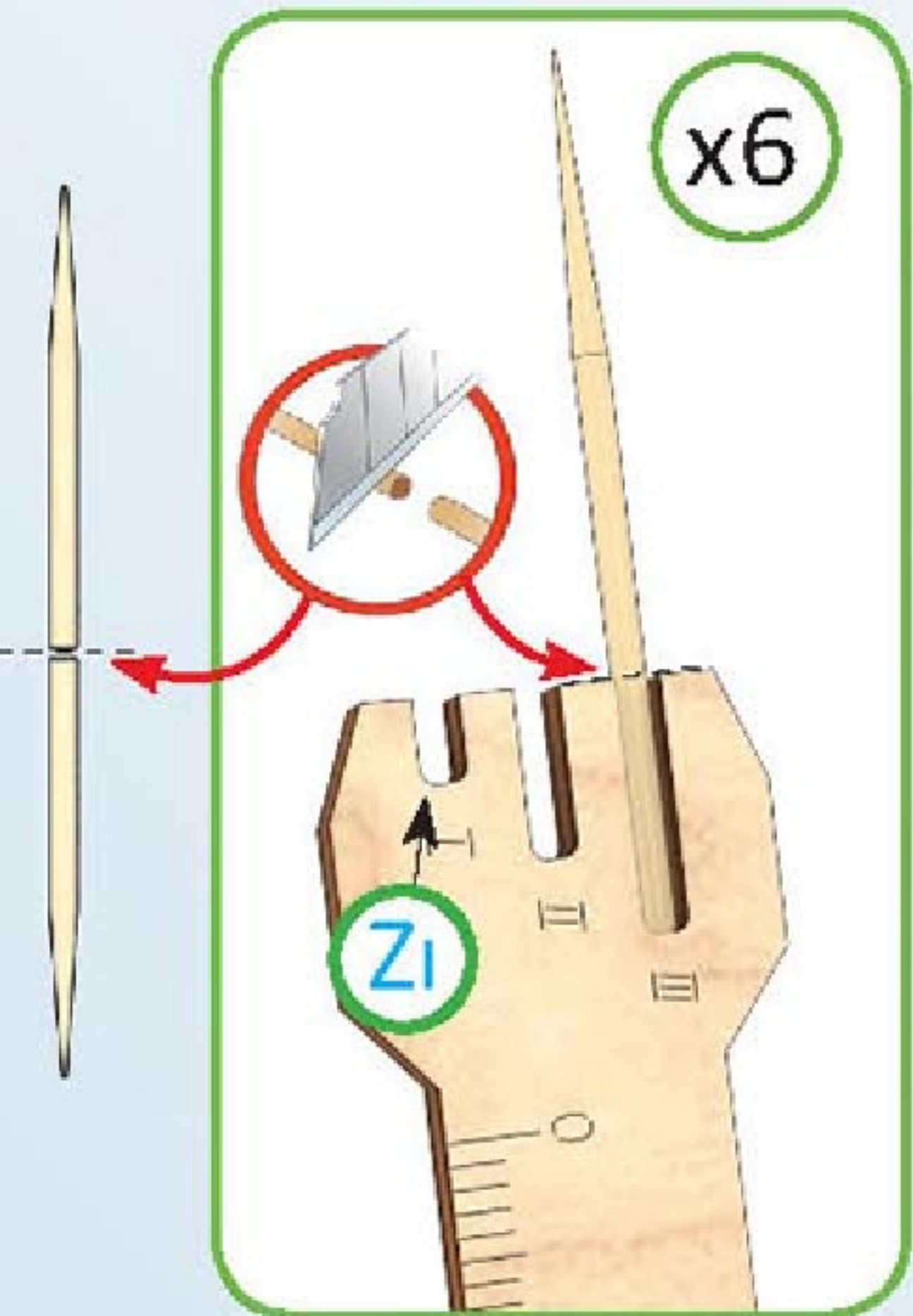
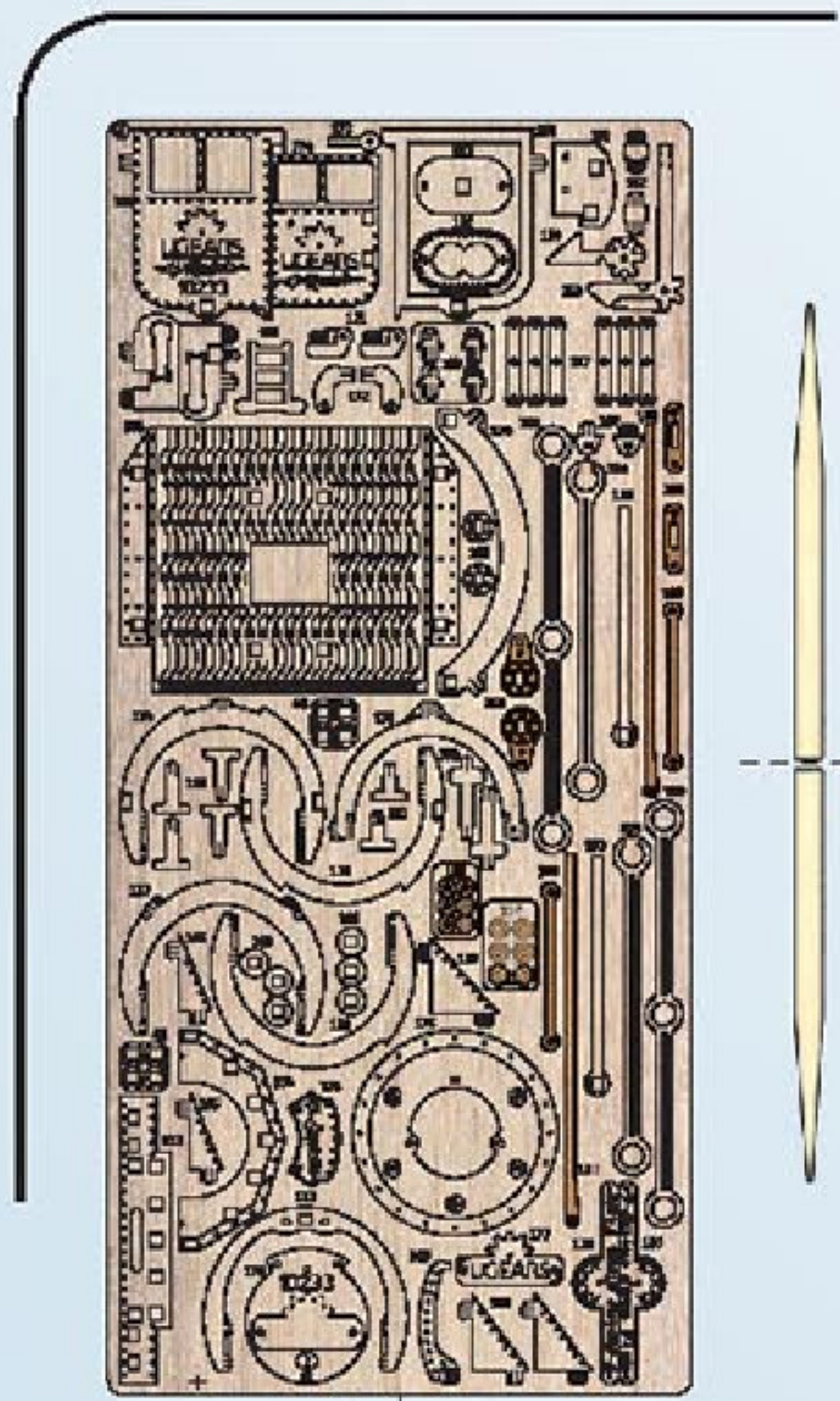



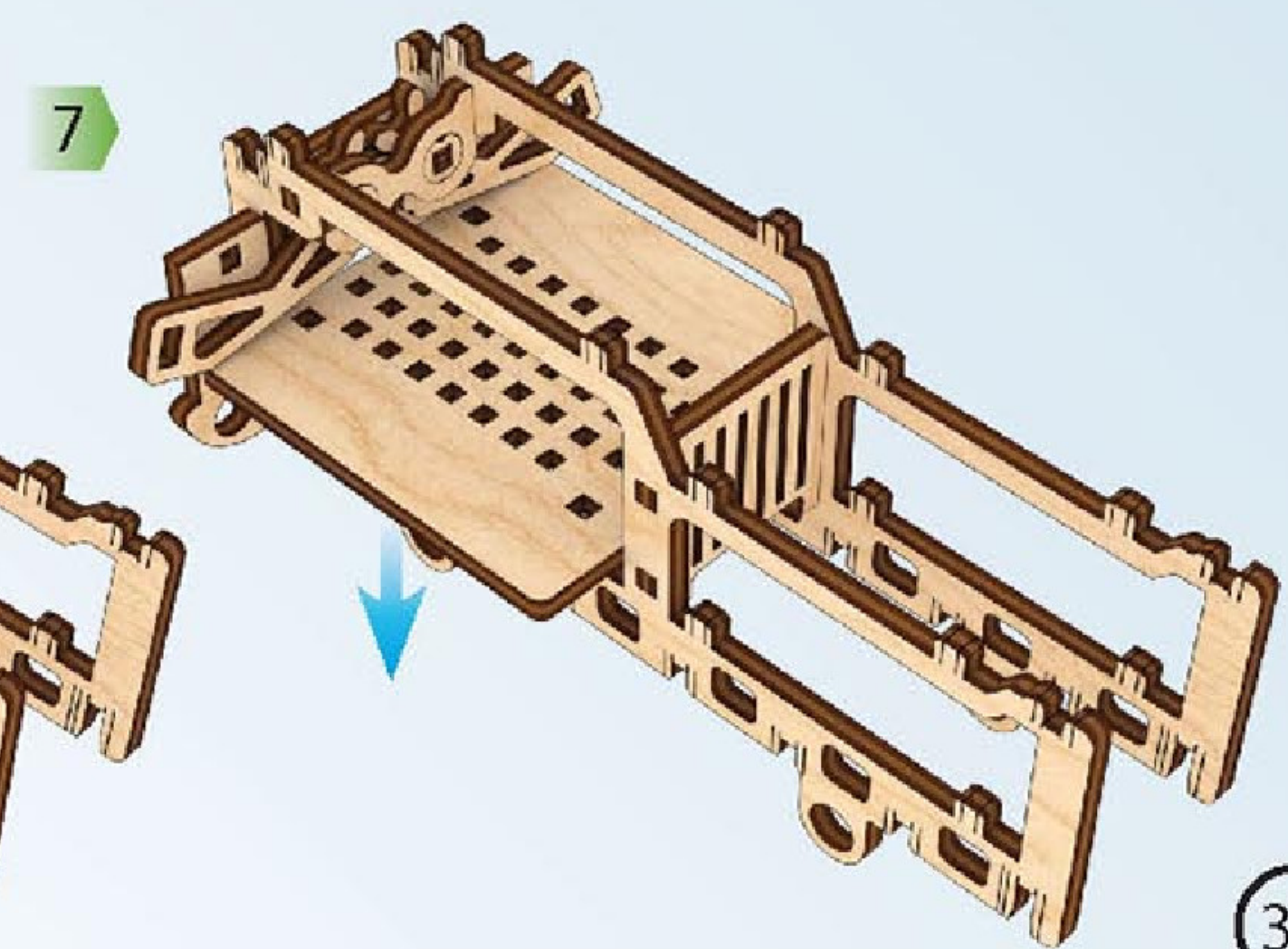
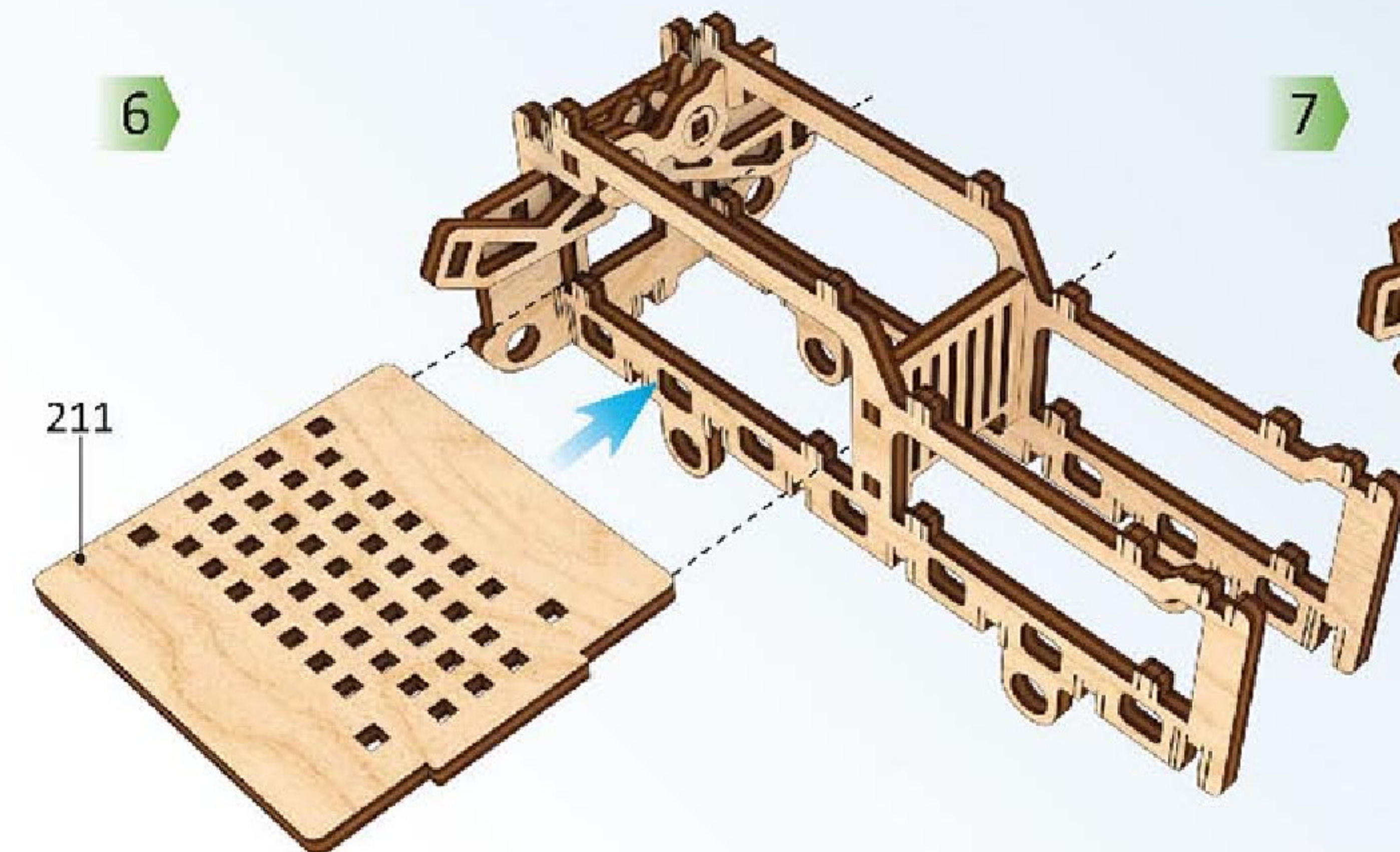
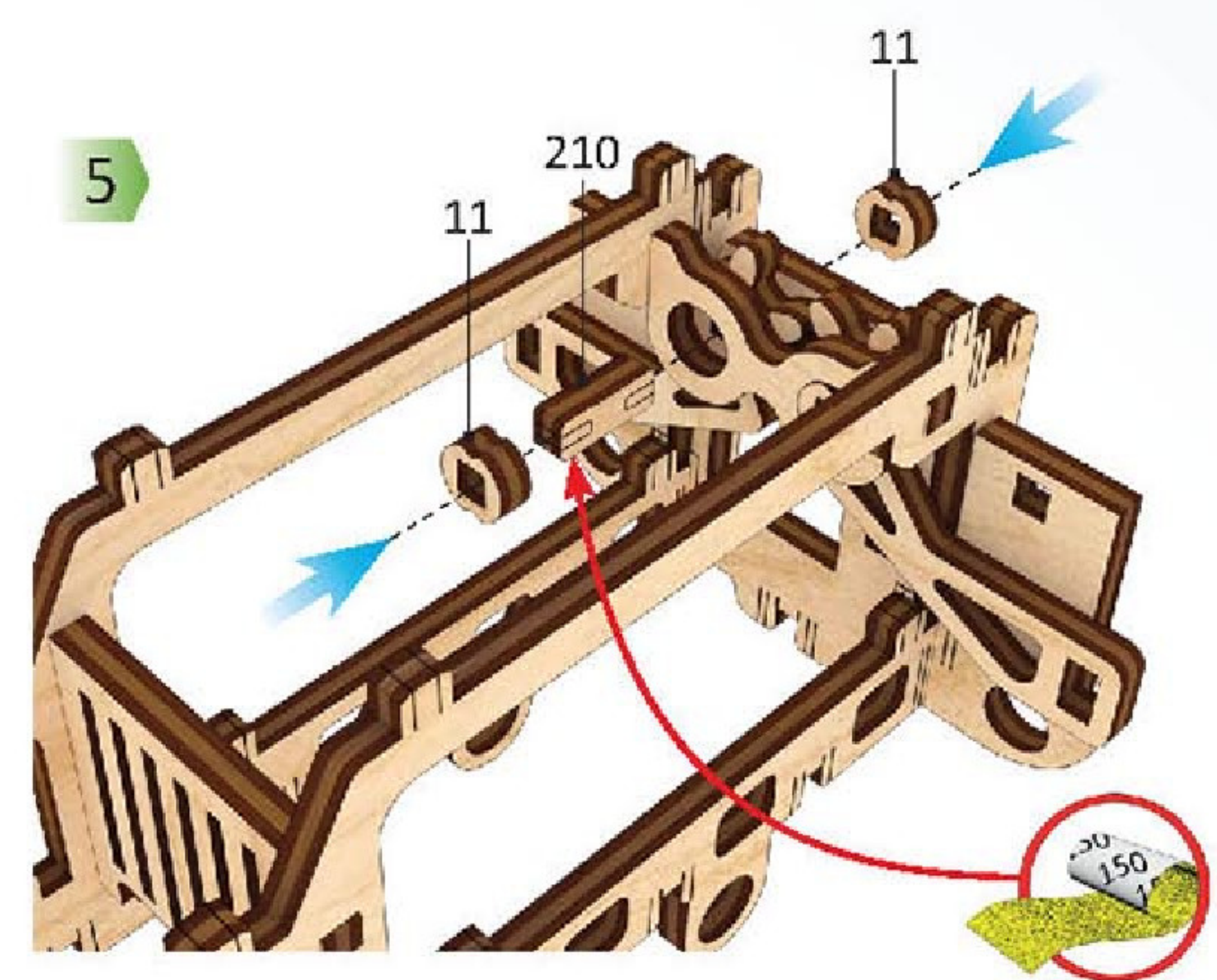
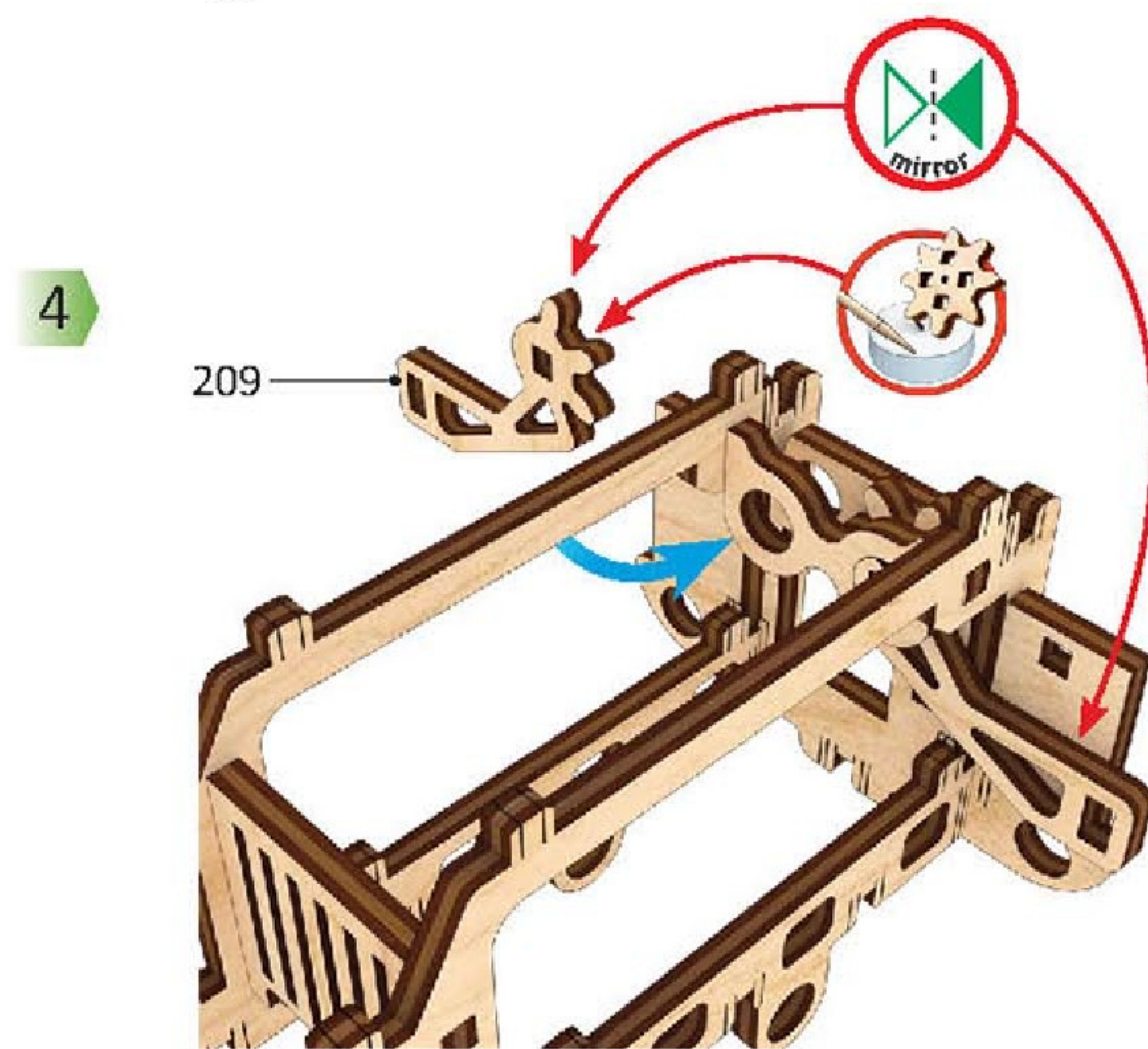
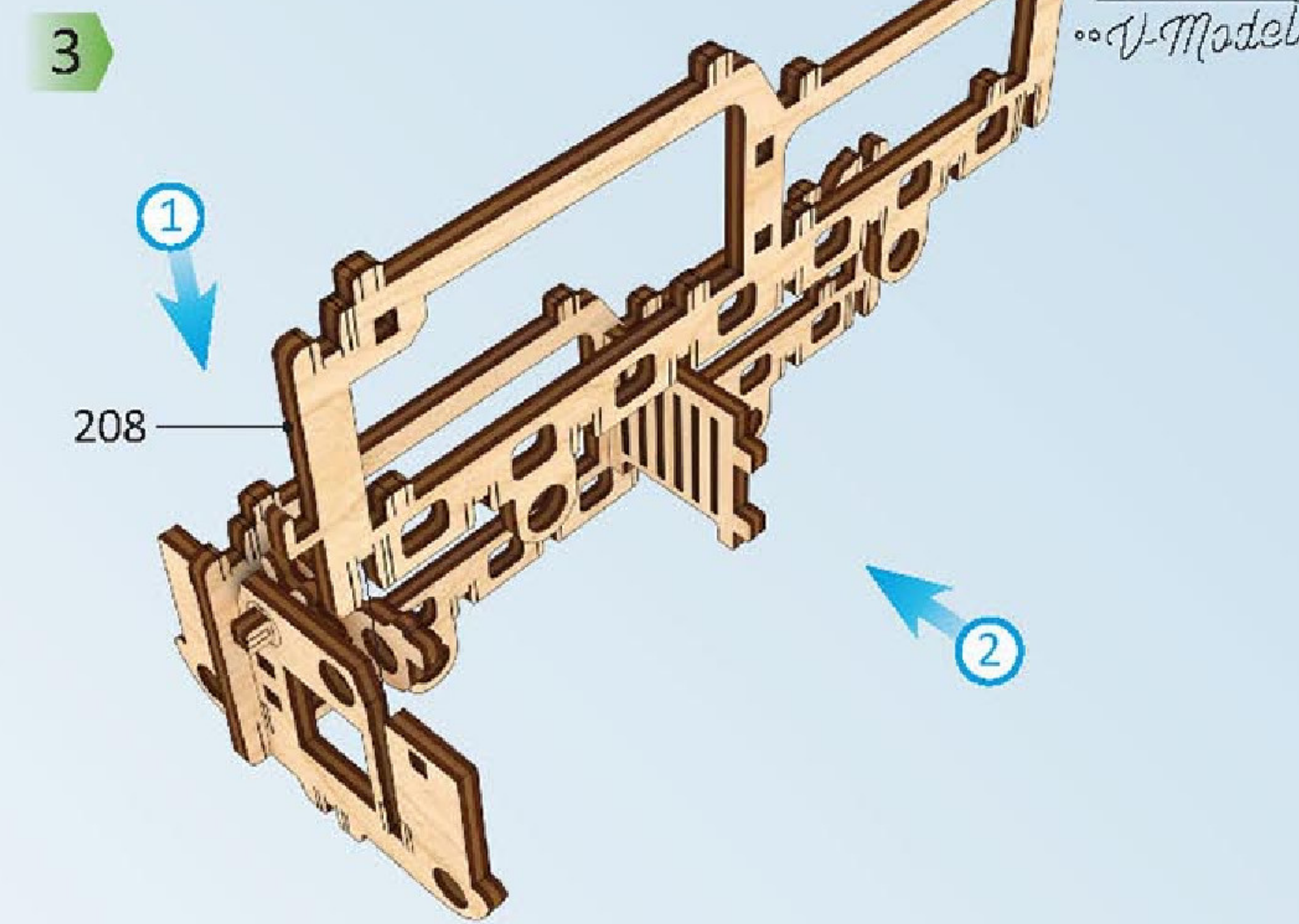
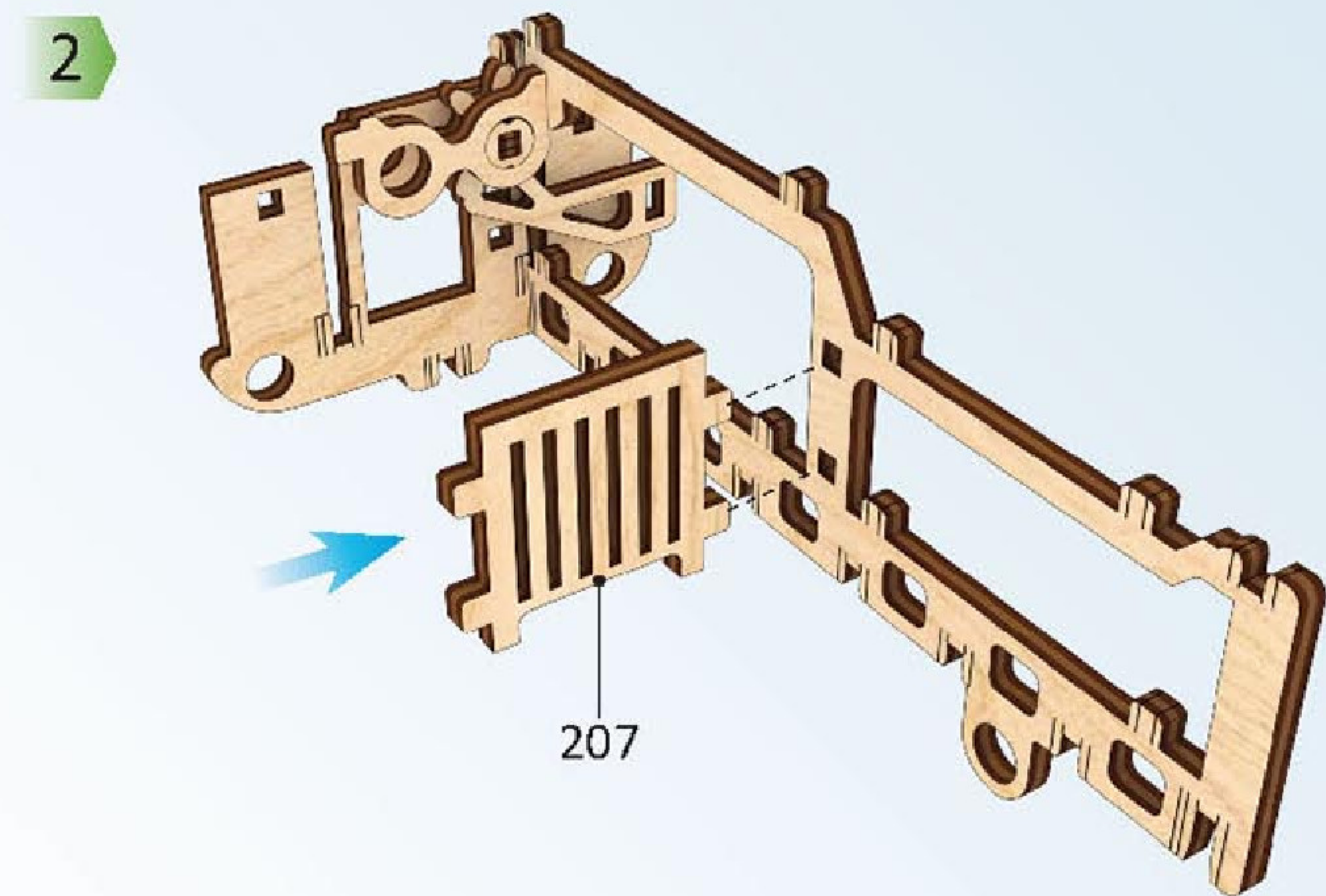
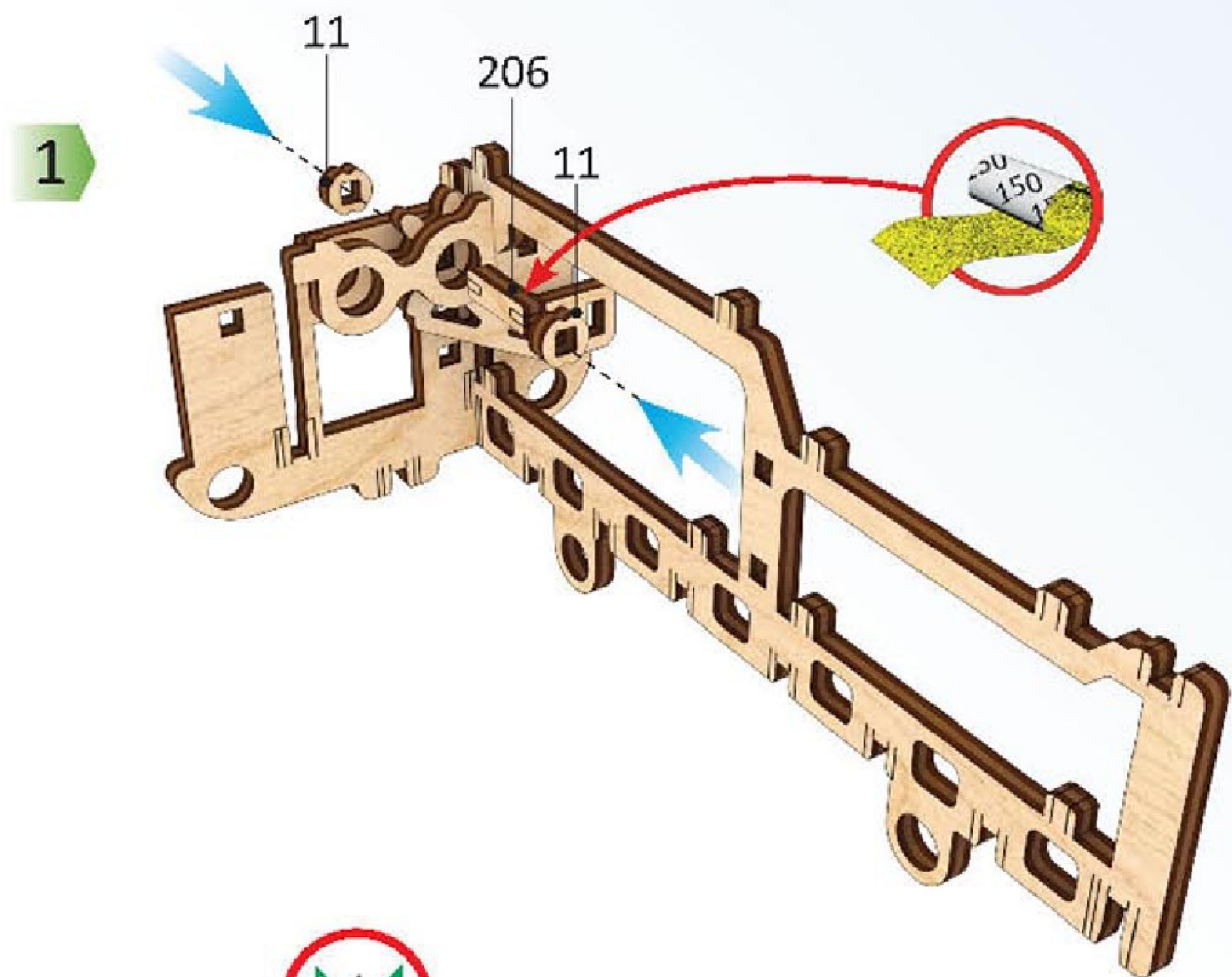
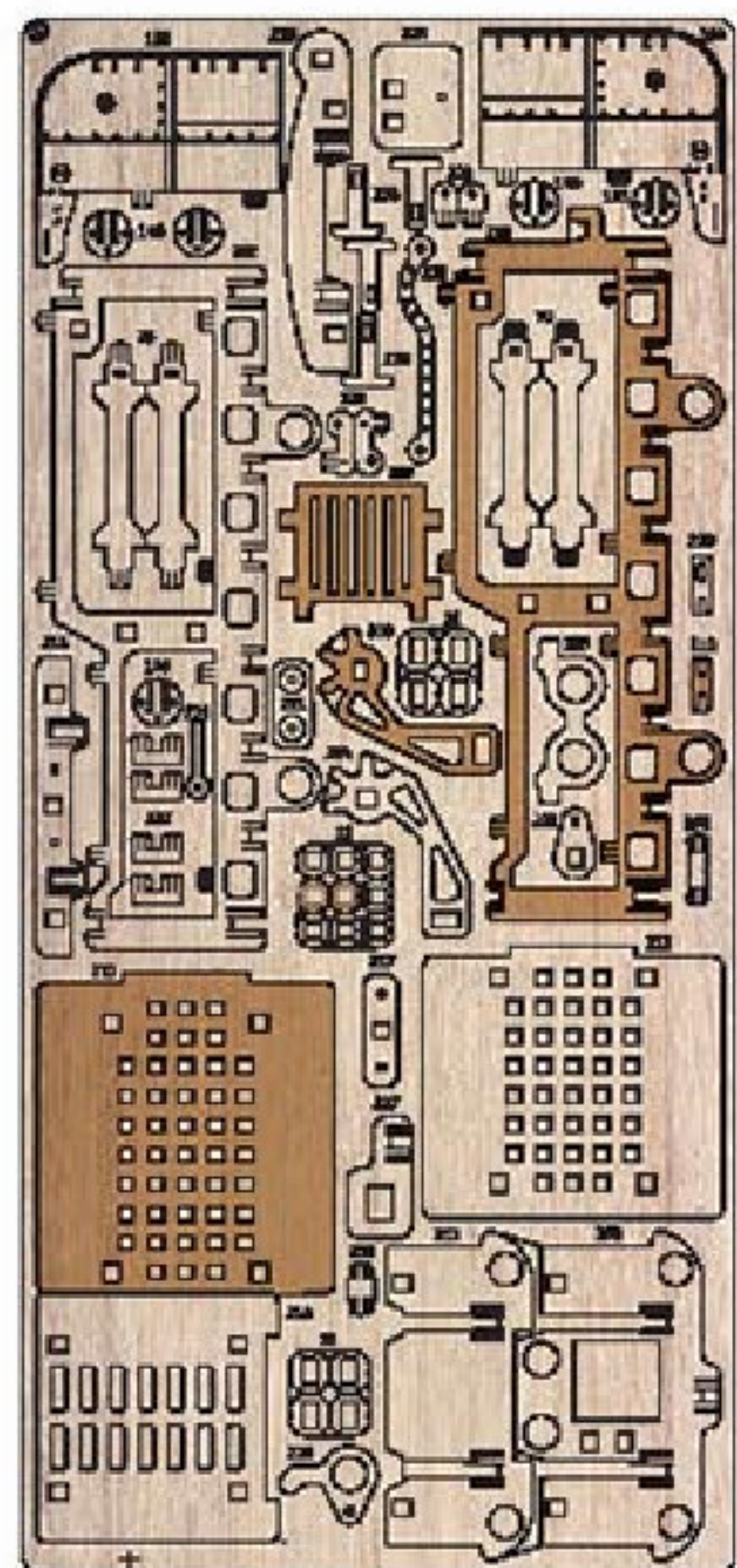

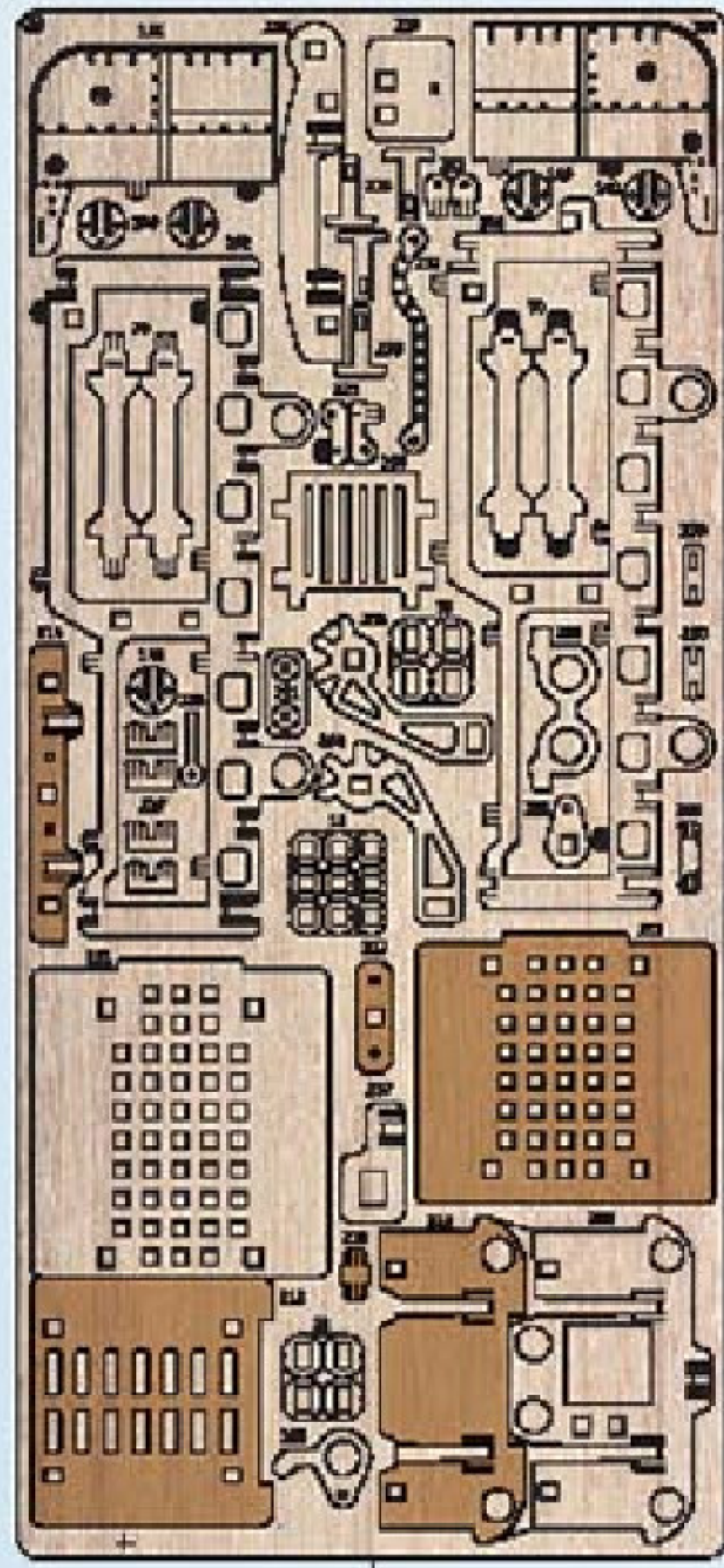

1

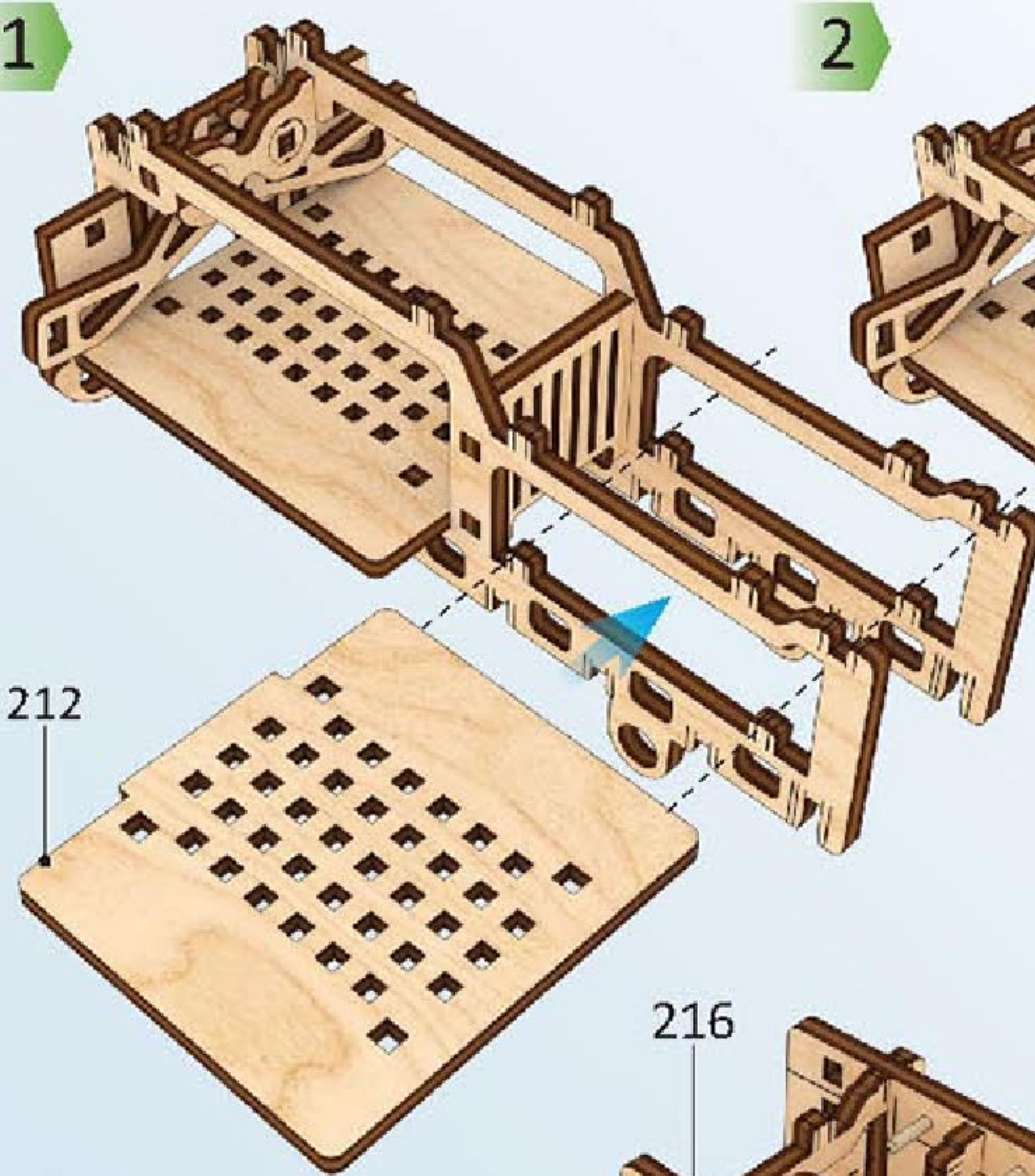

2

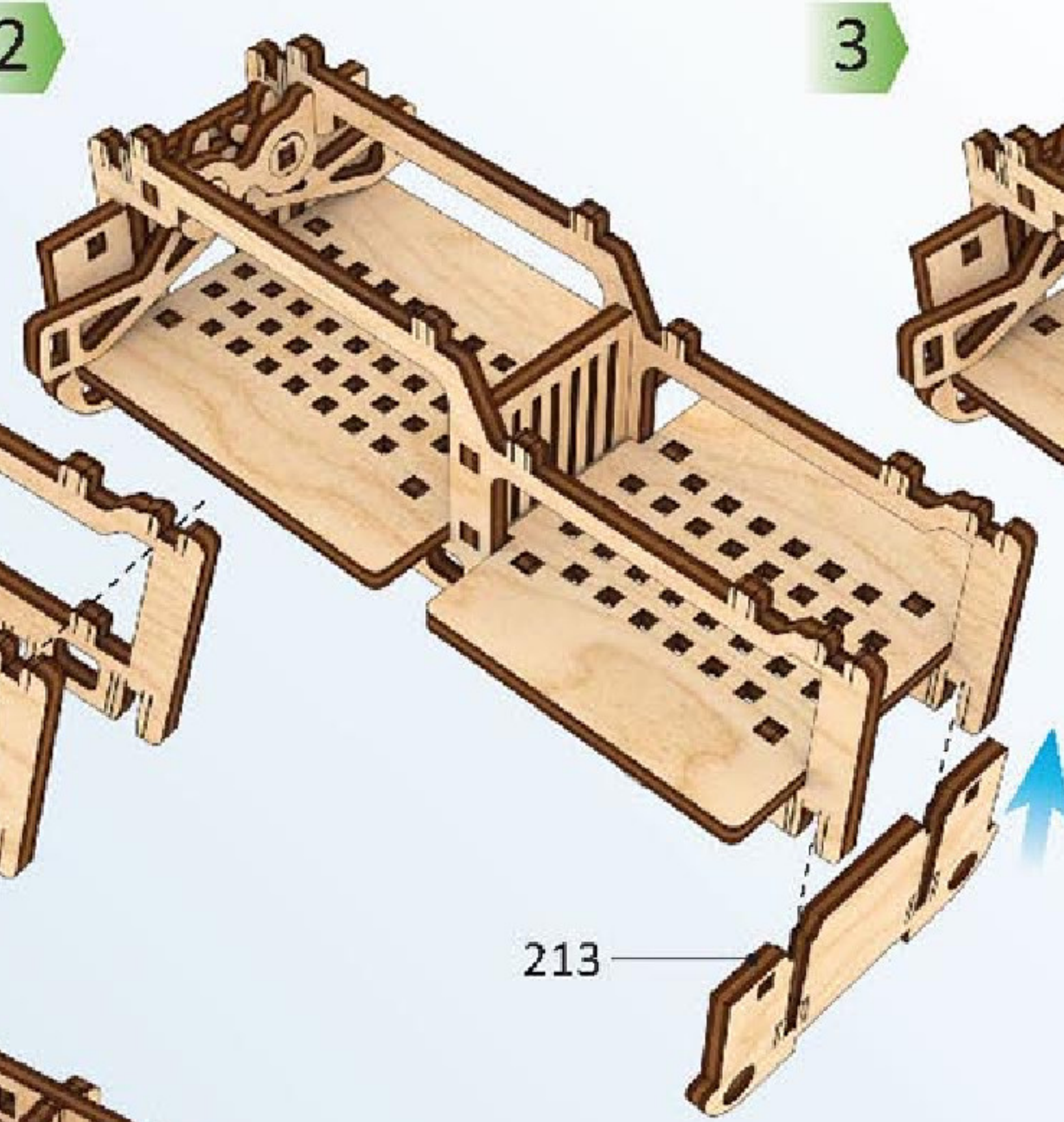

3

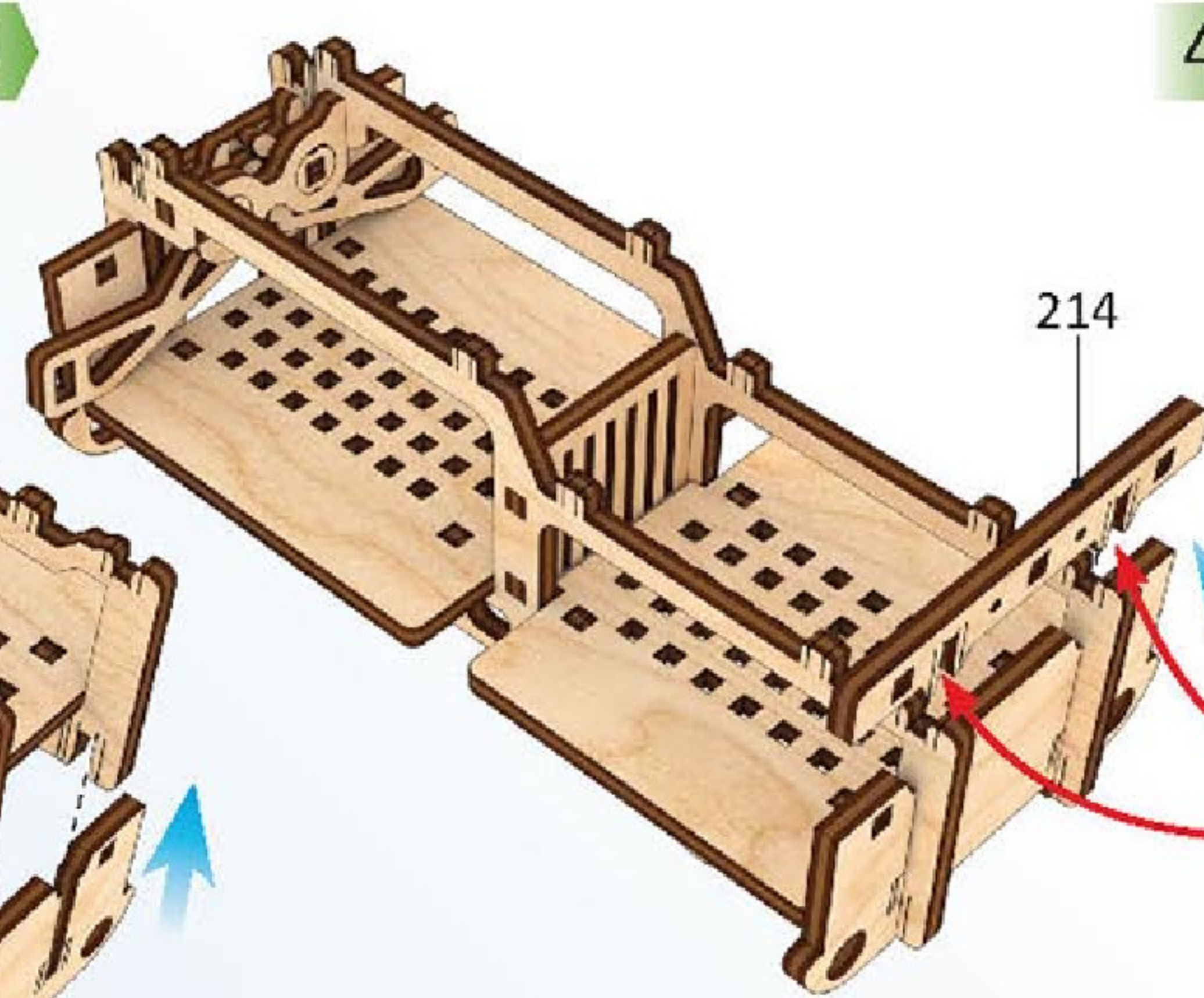

4

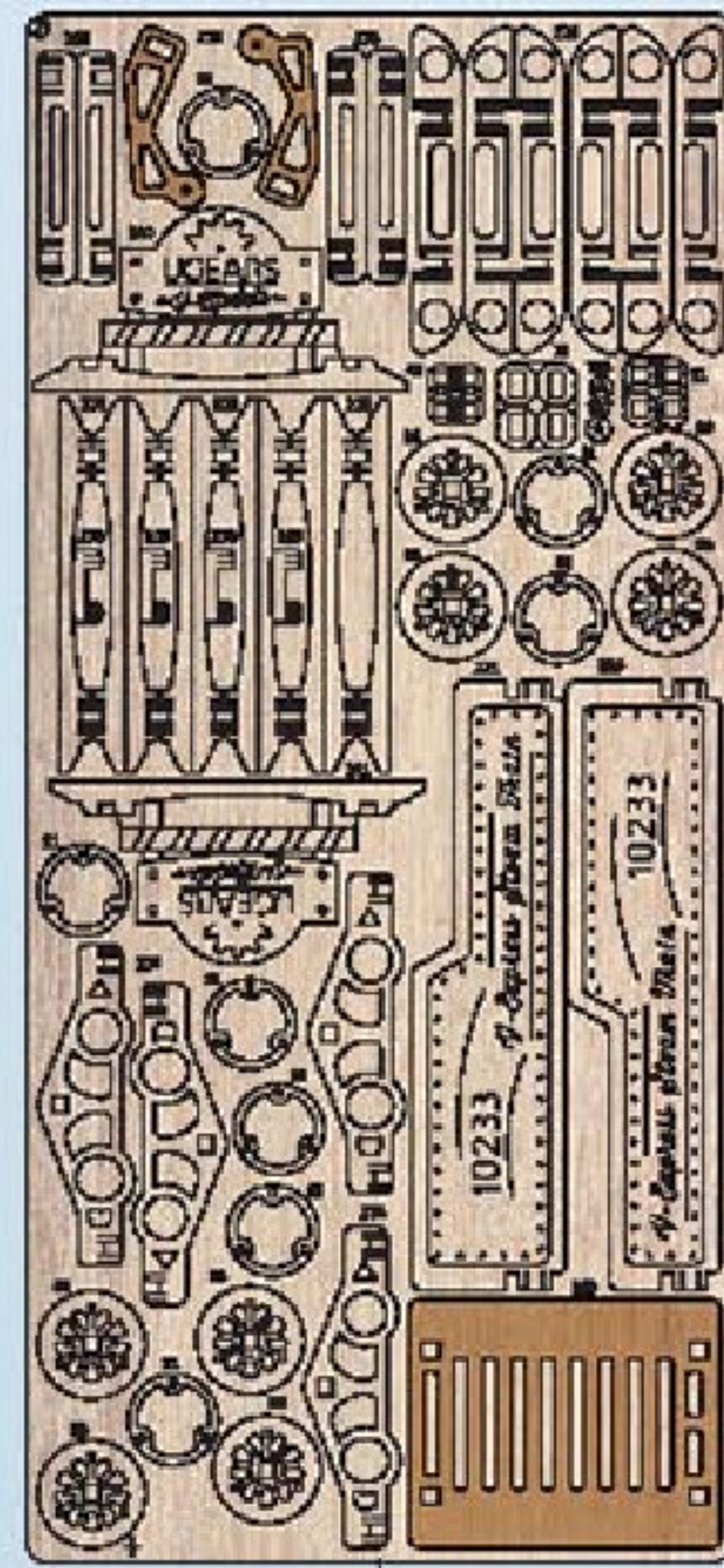
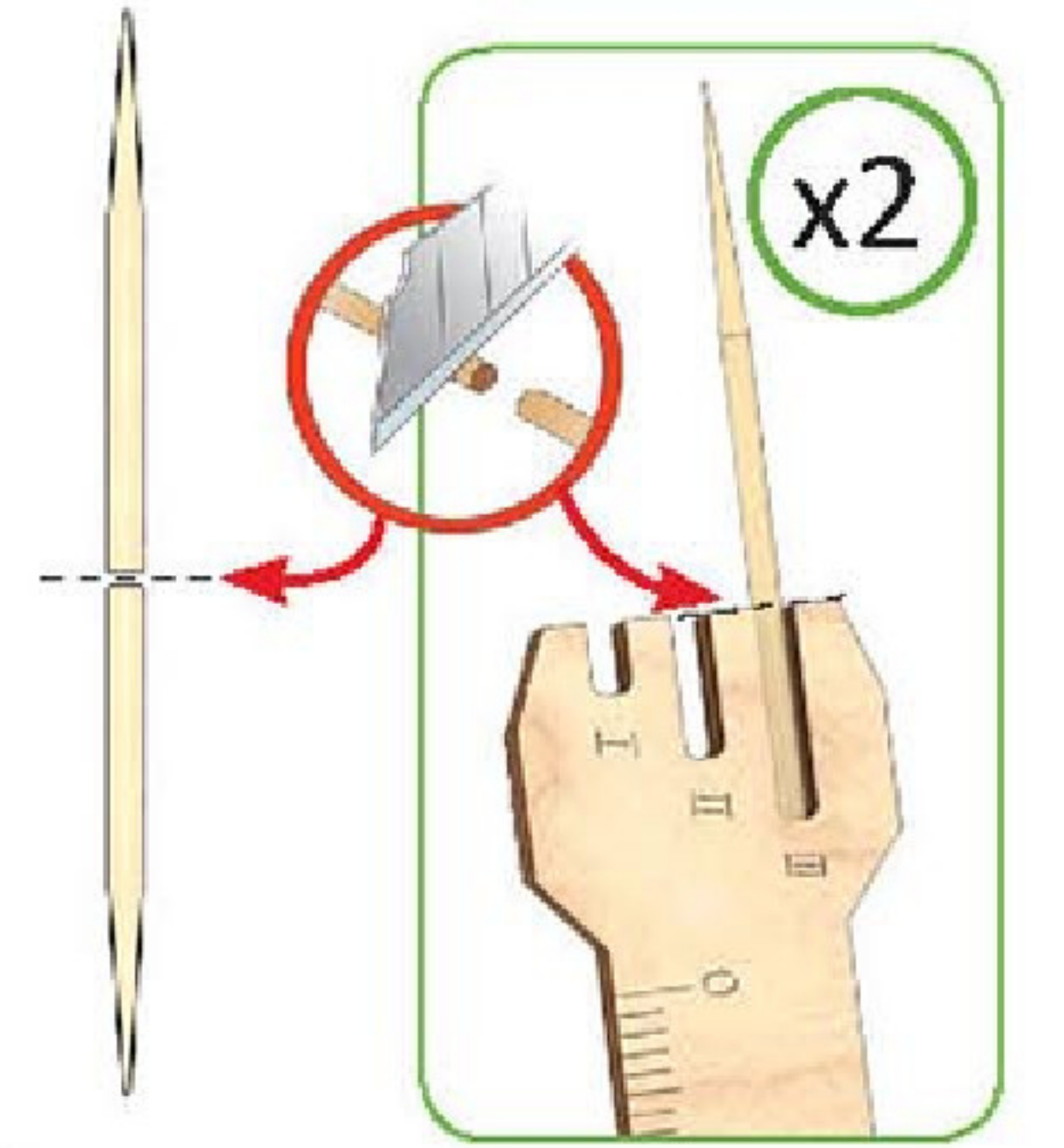
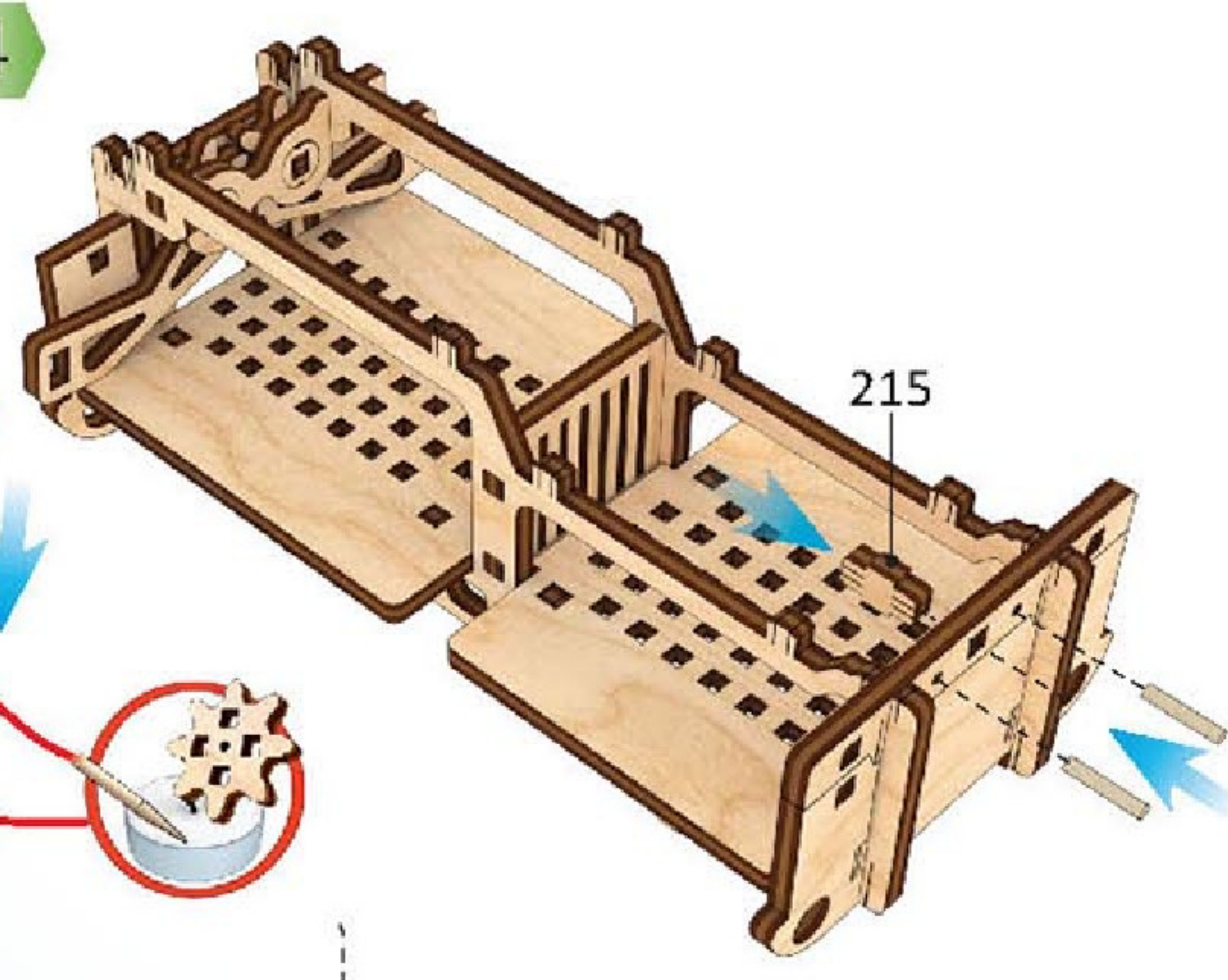

5

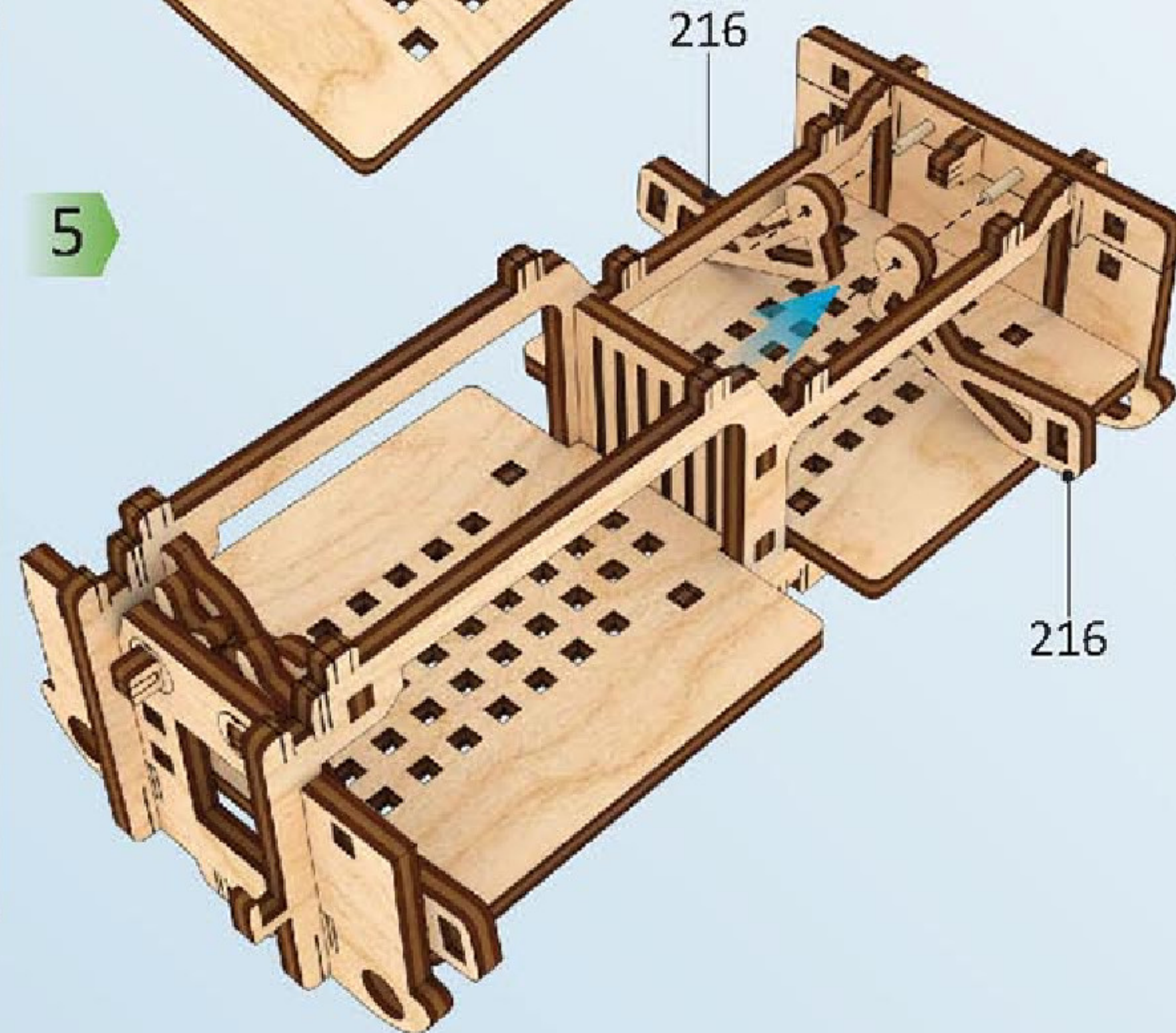

6

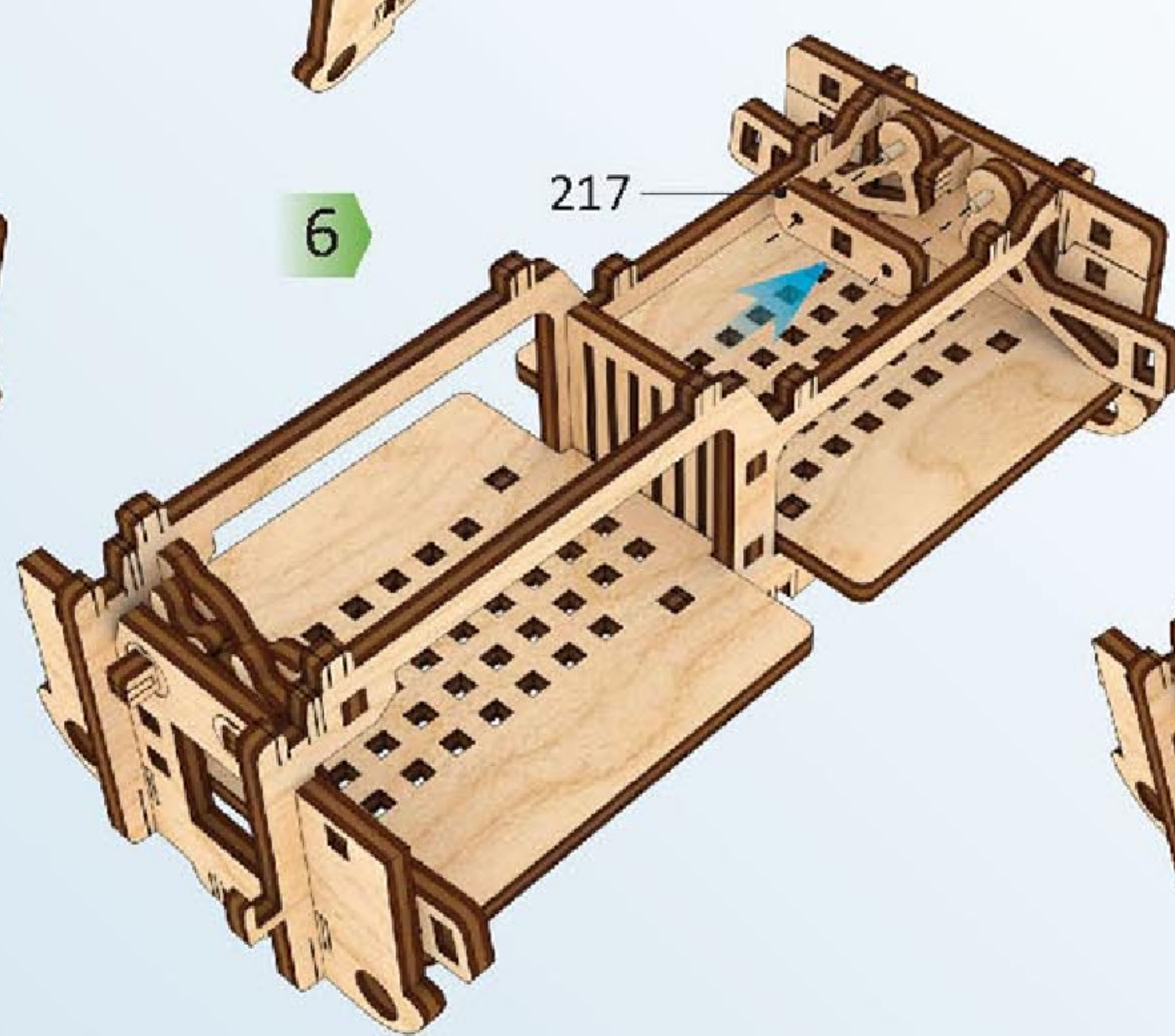

7

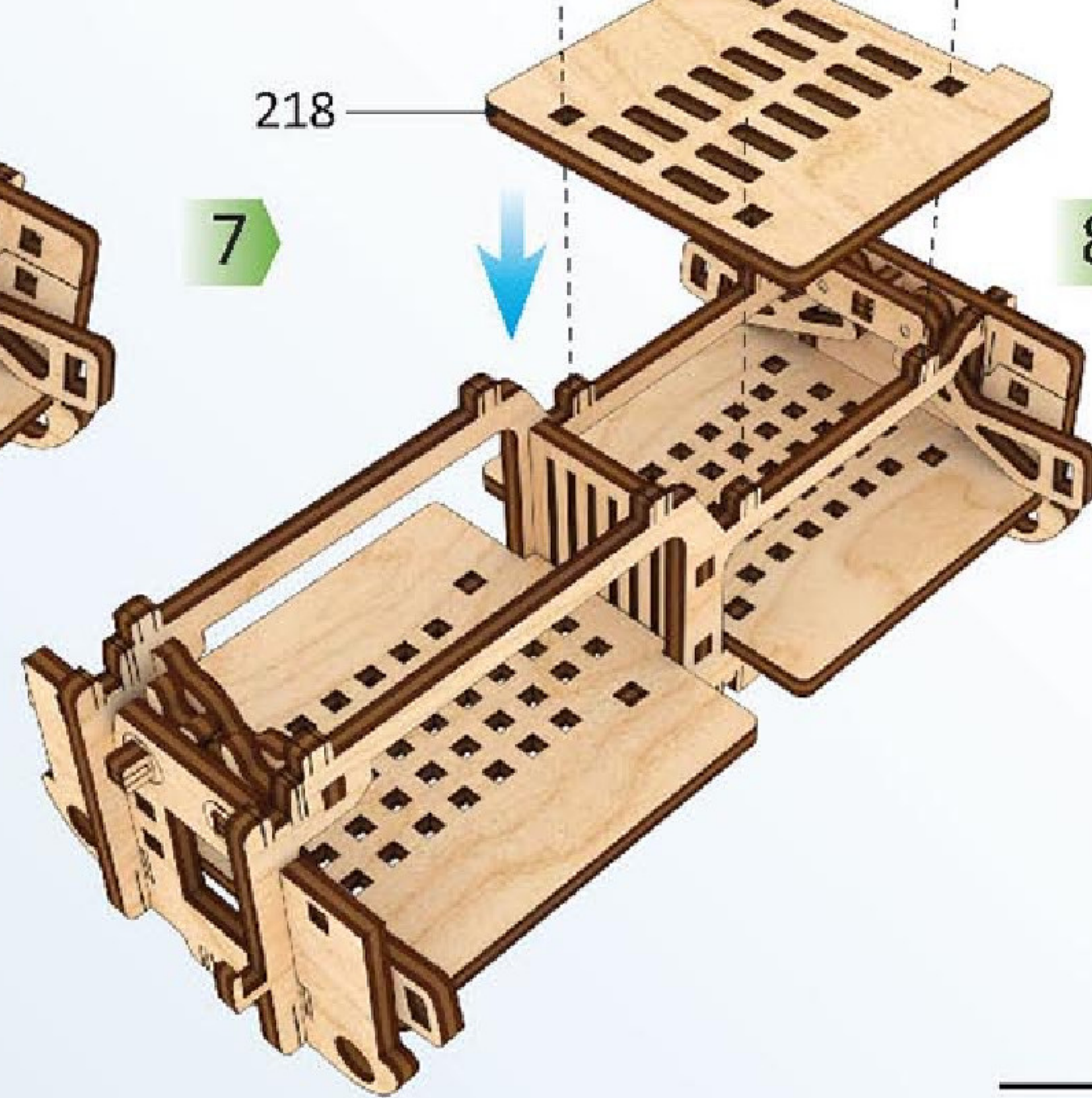

8

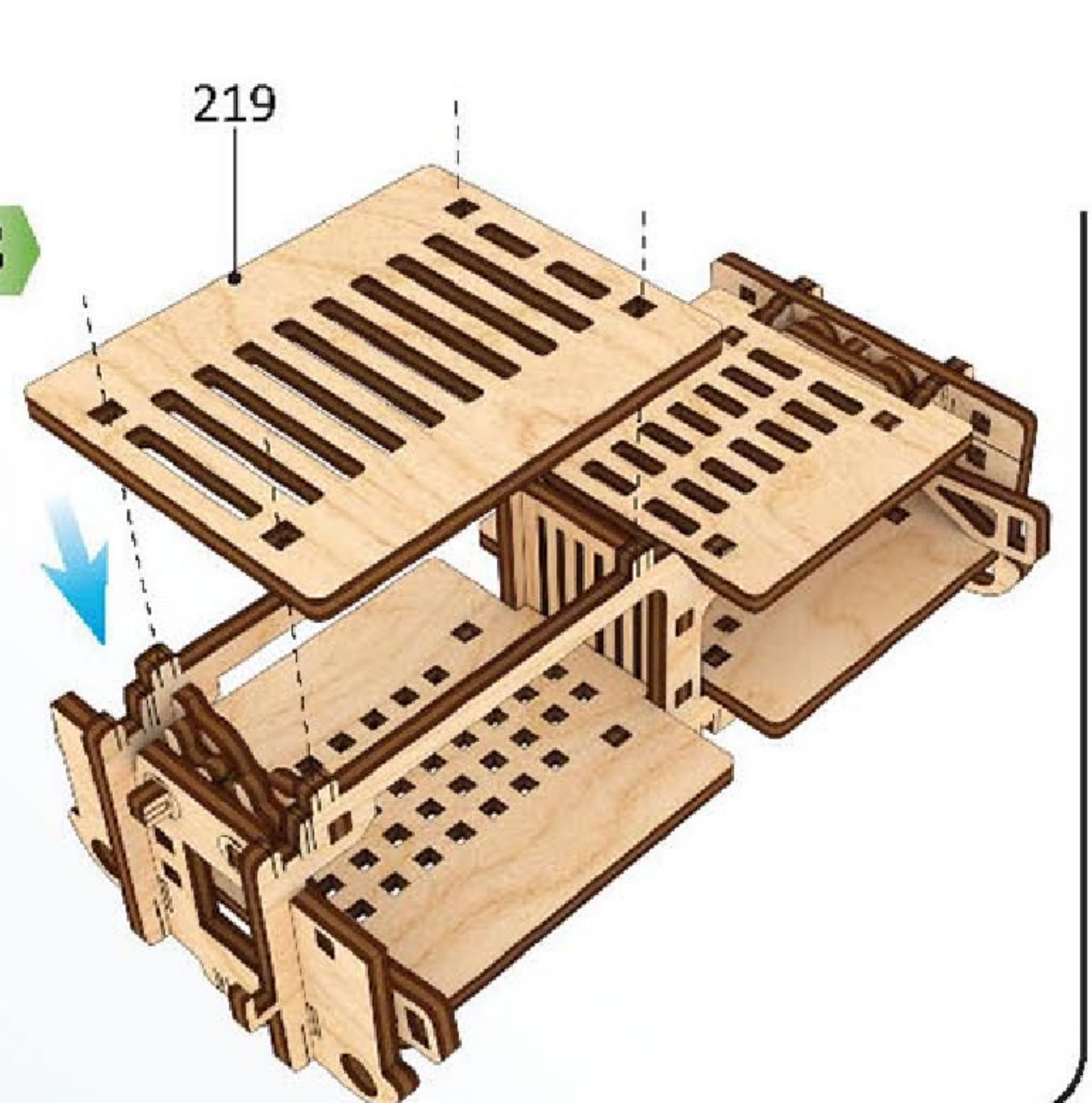

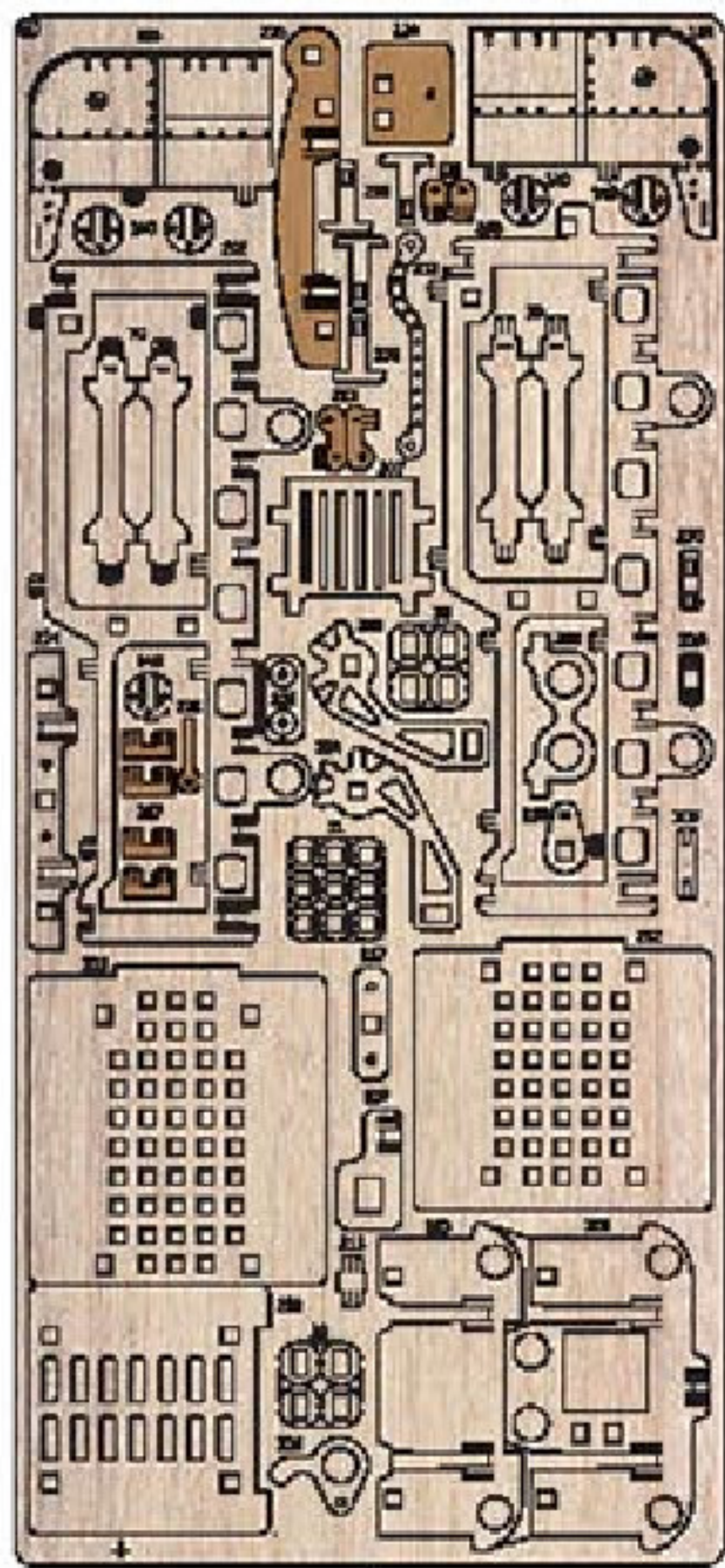

6

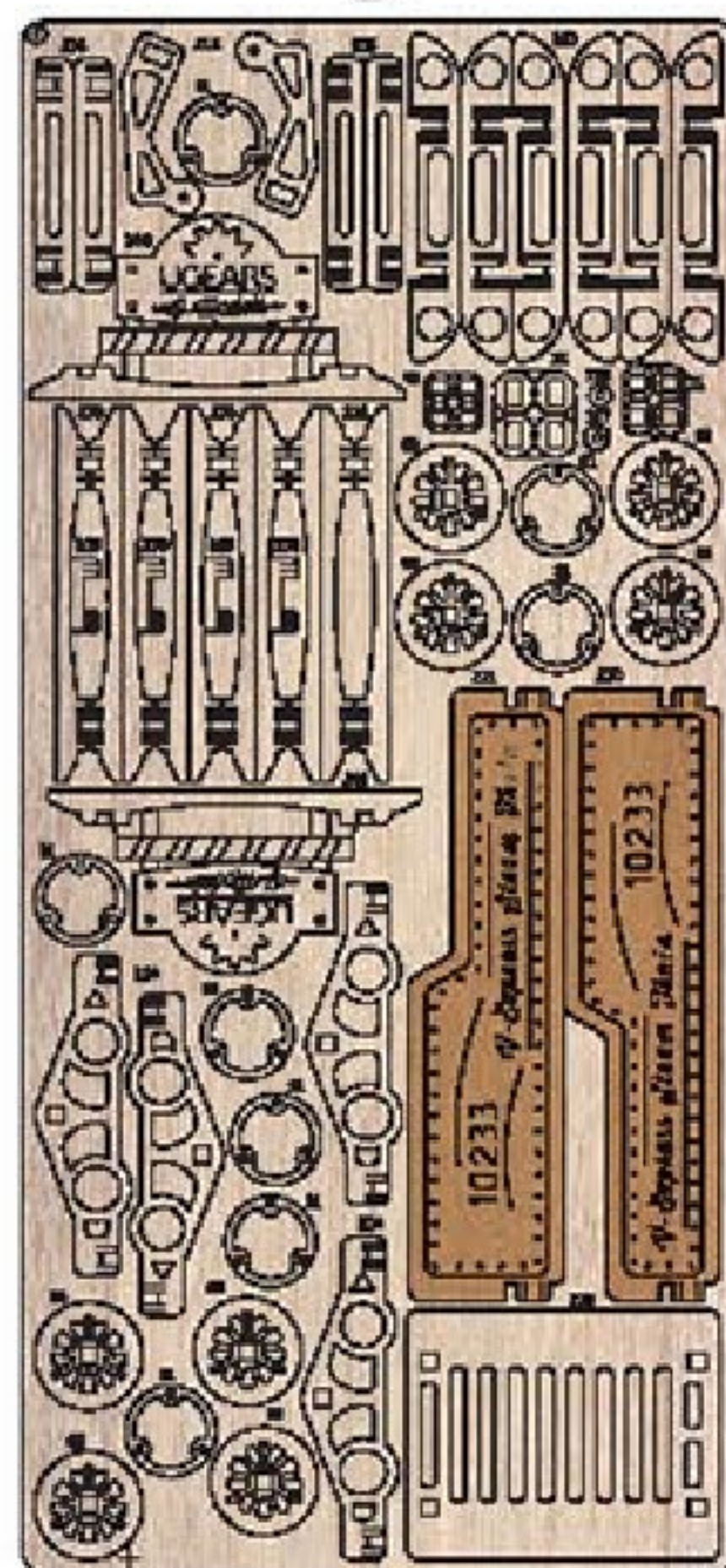

7

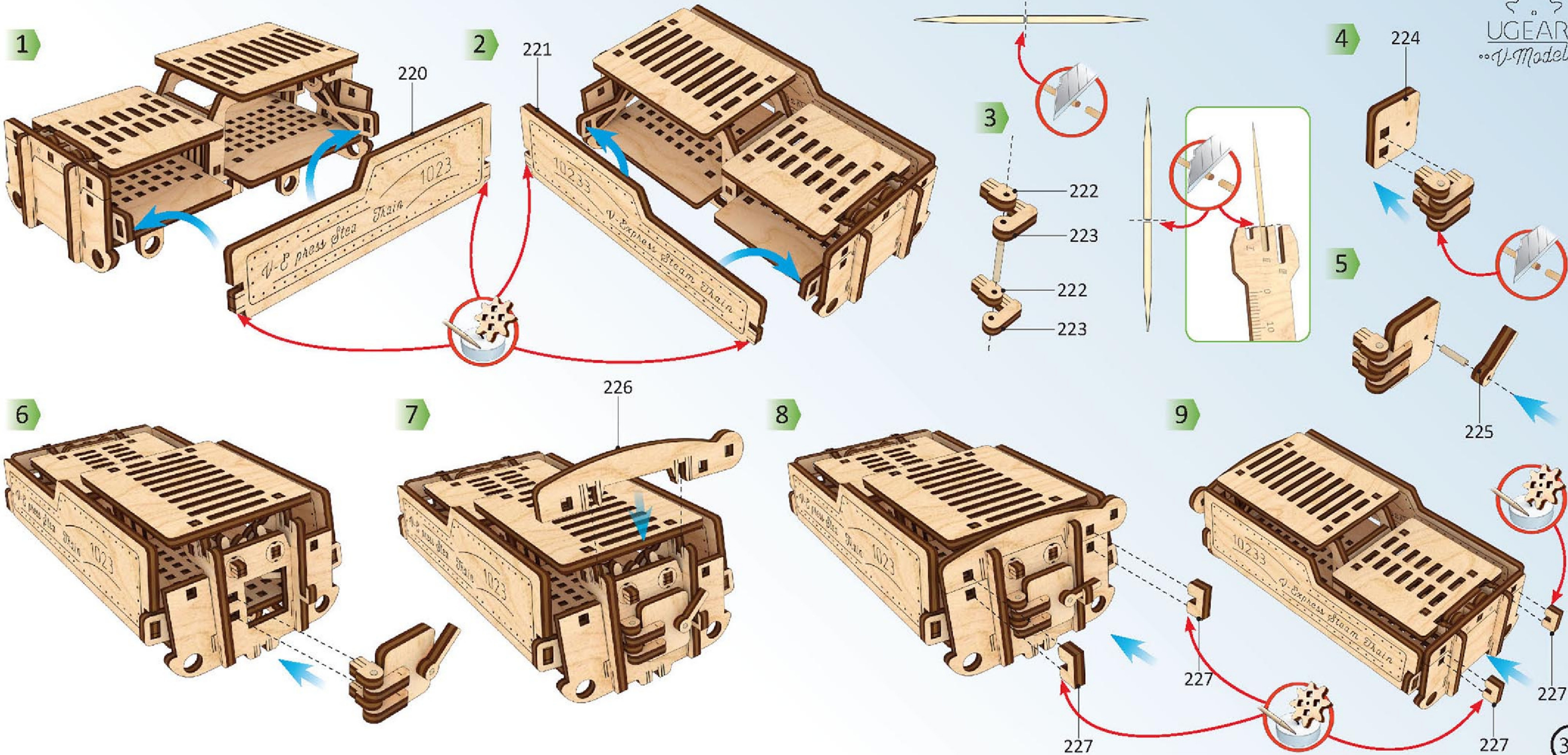

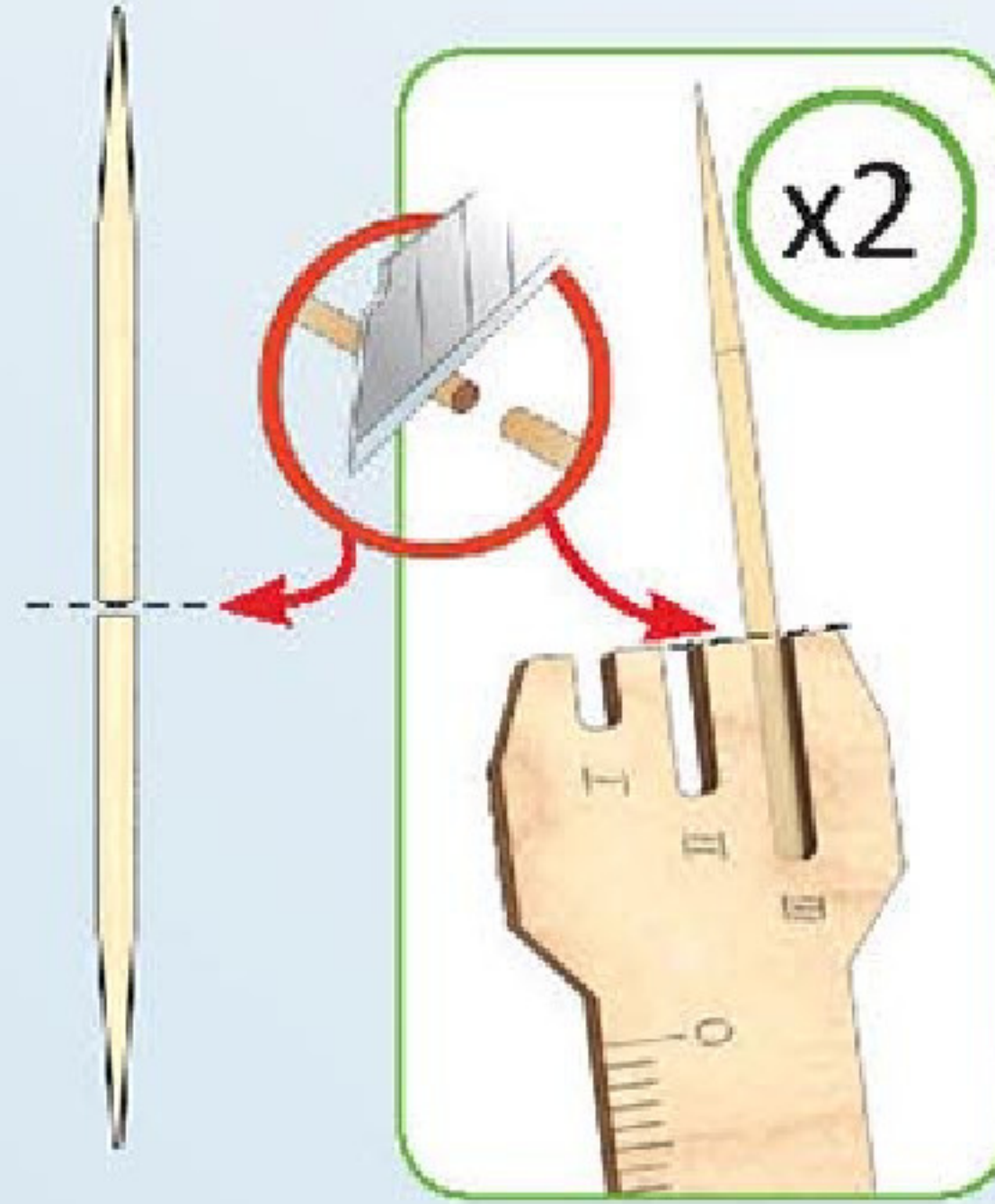
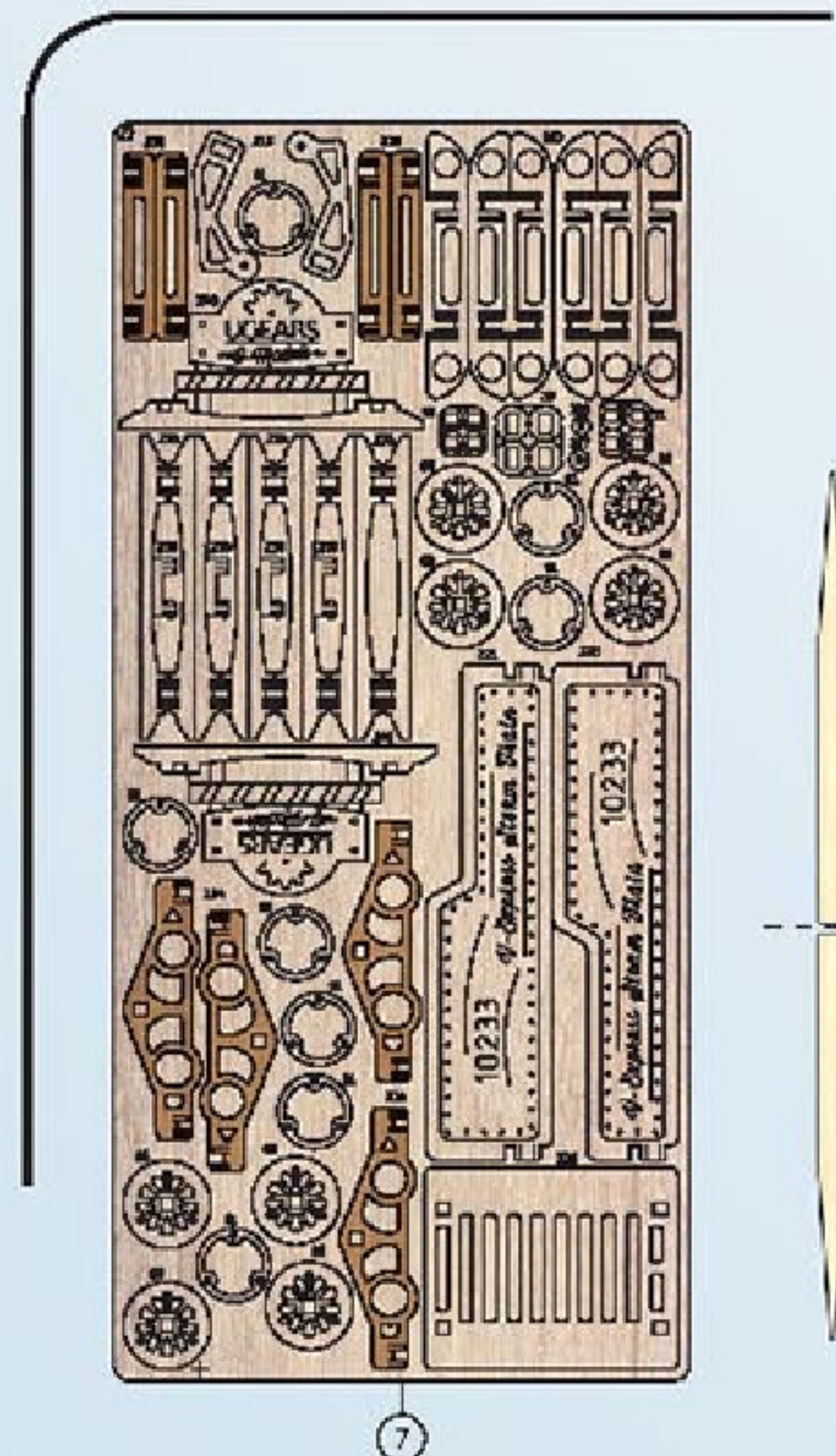

1

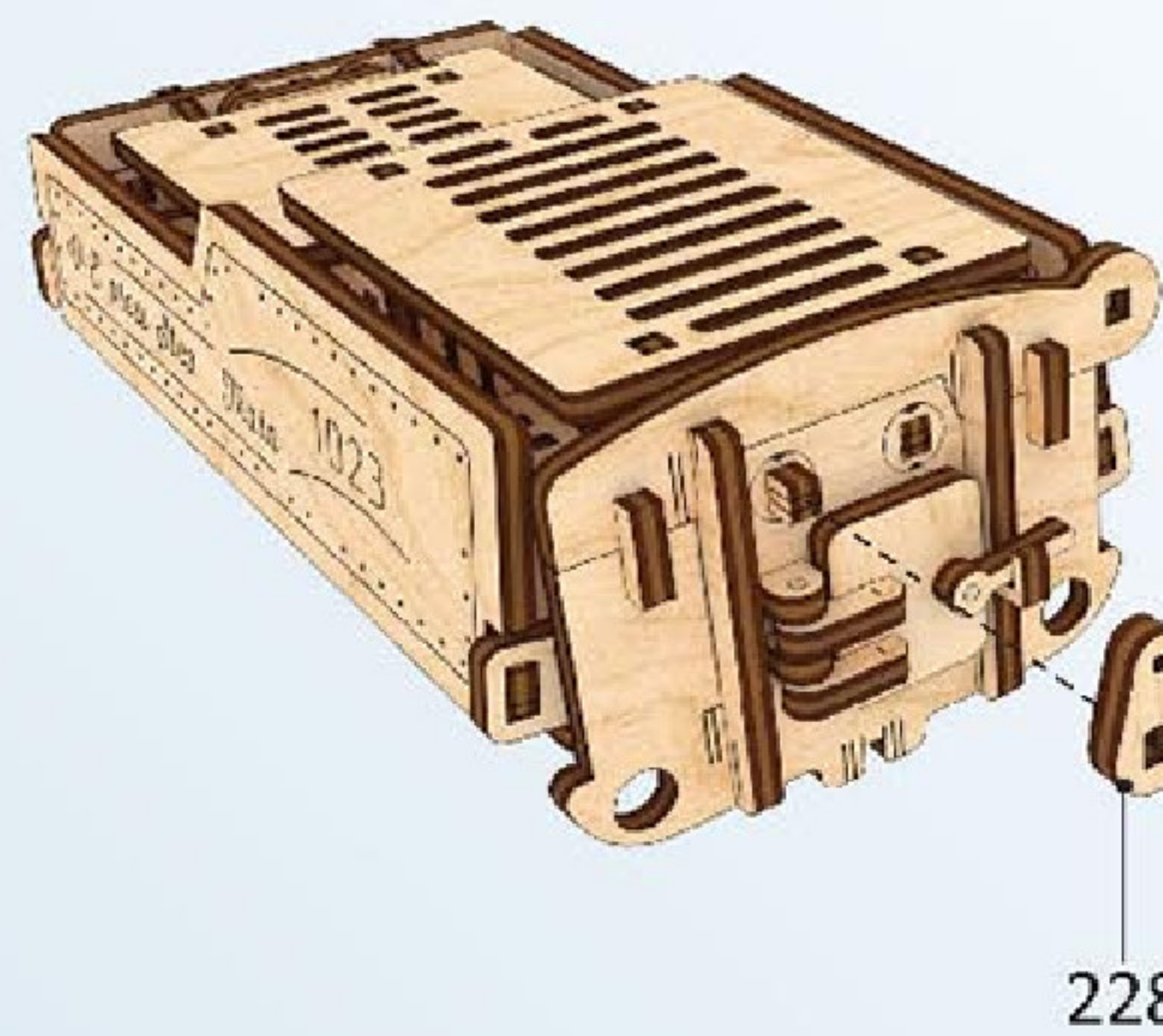

2

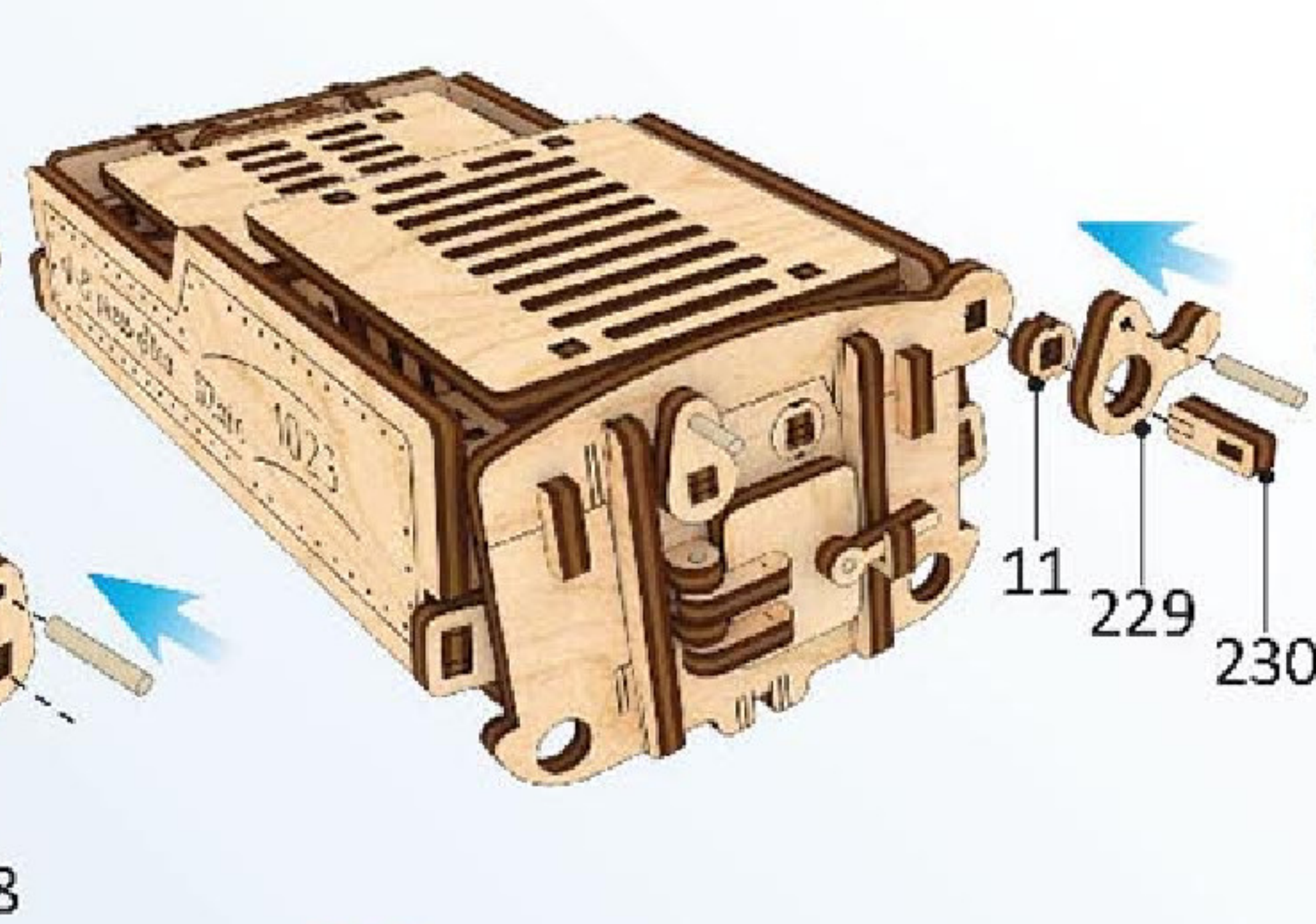

3



4

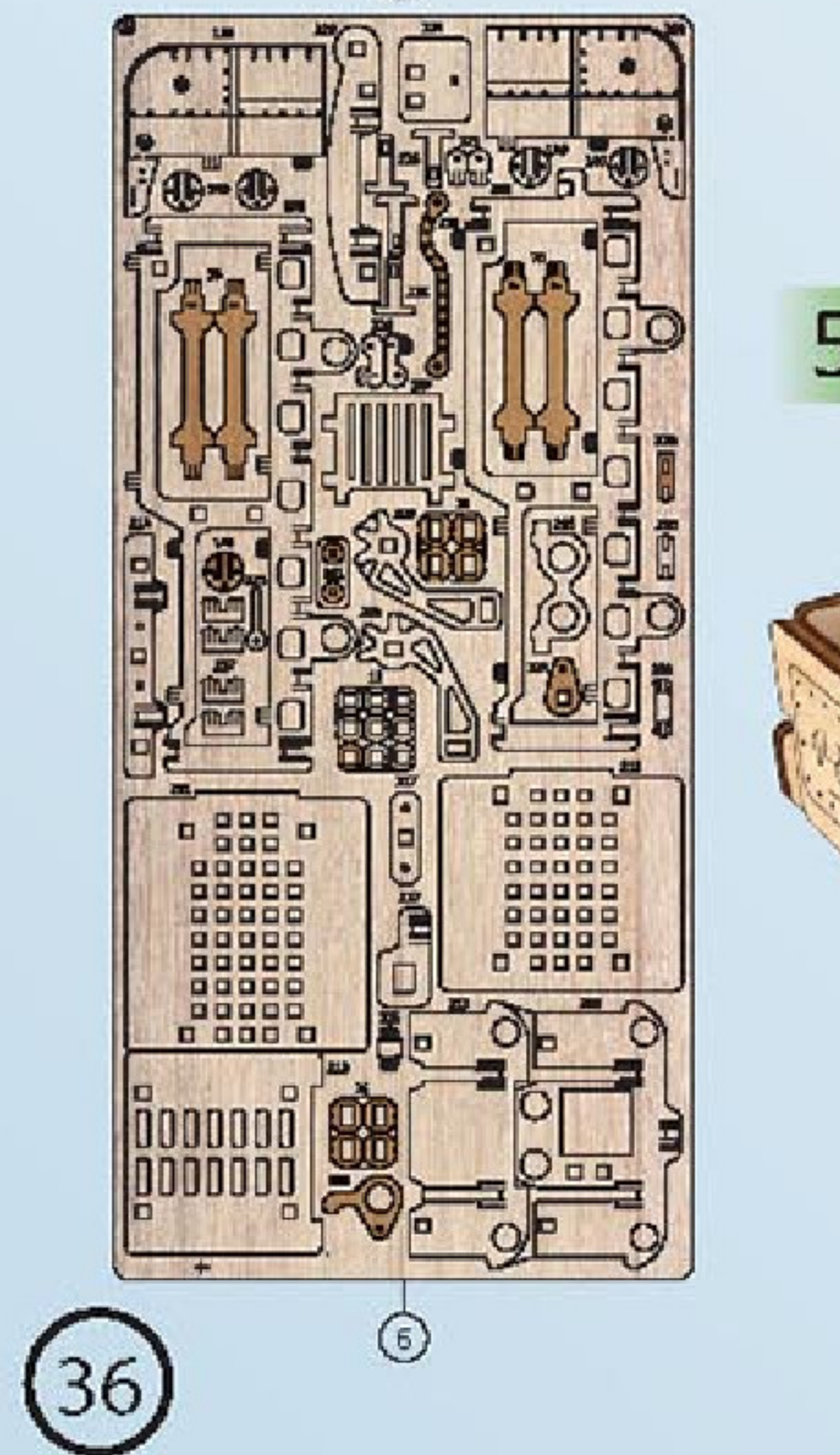
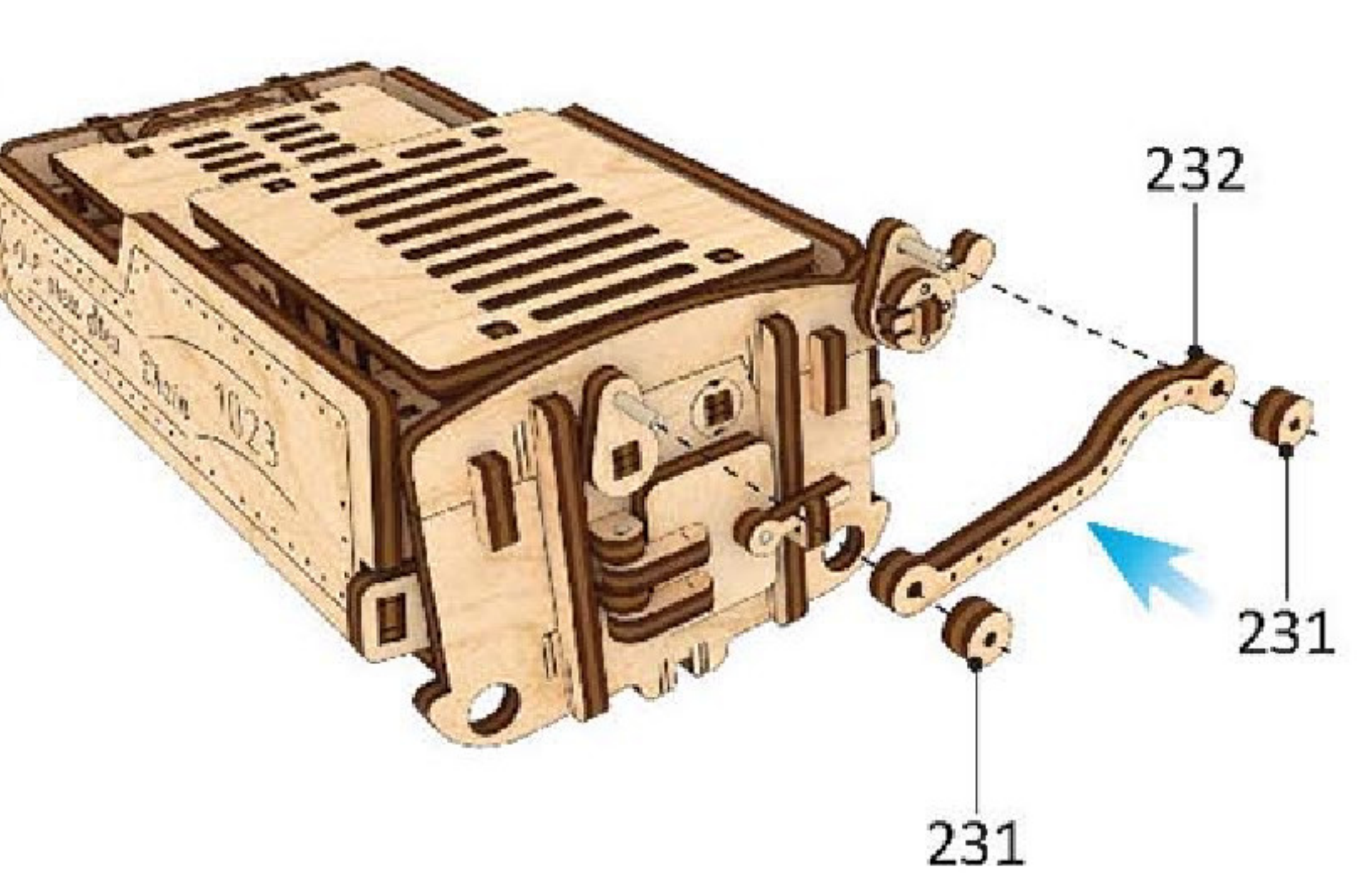

5

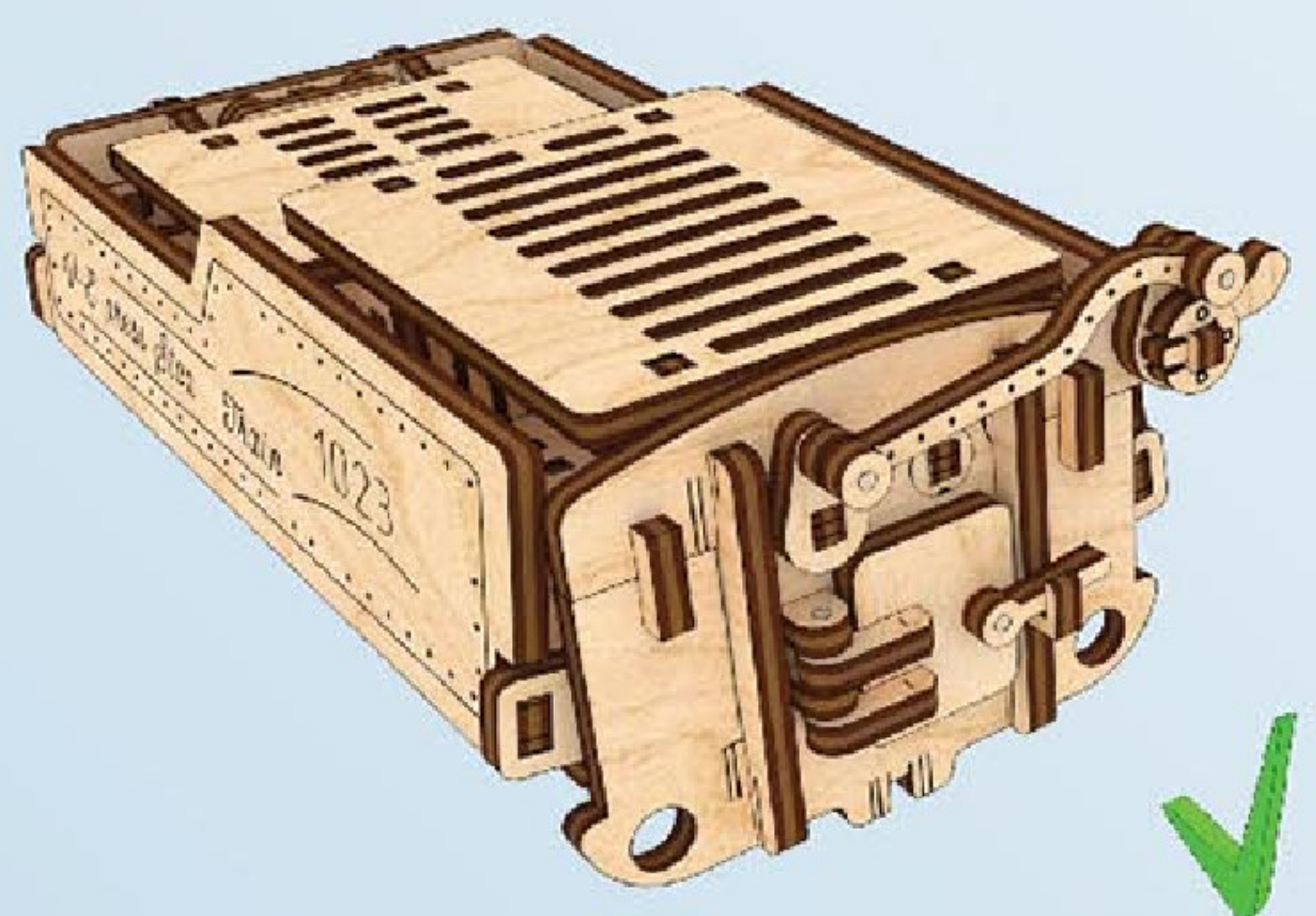

6

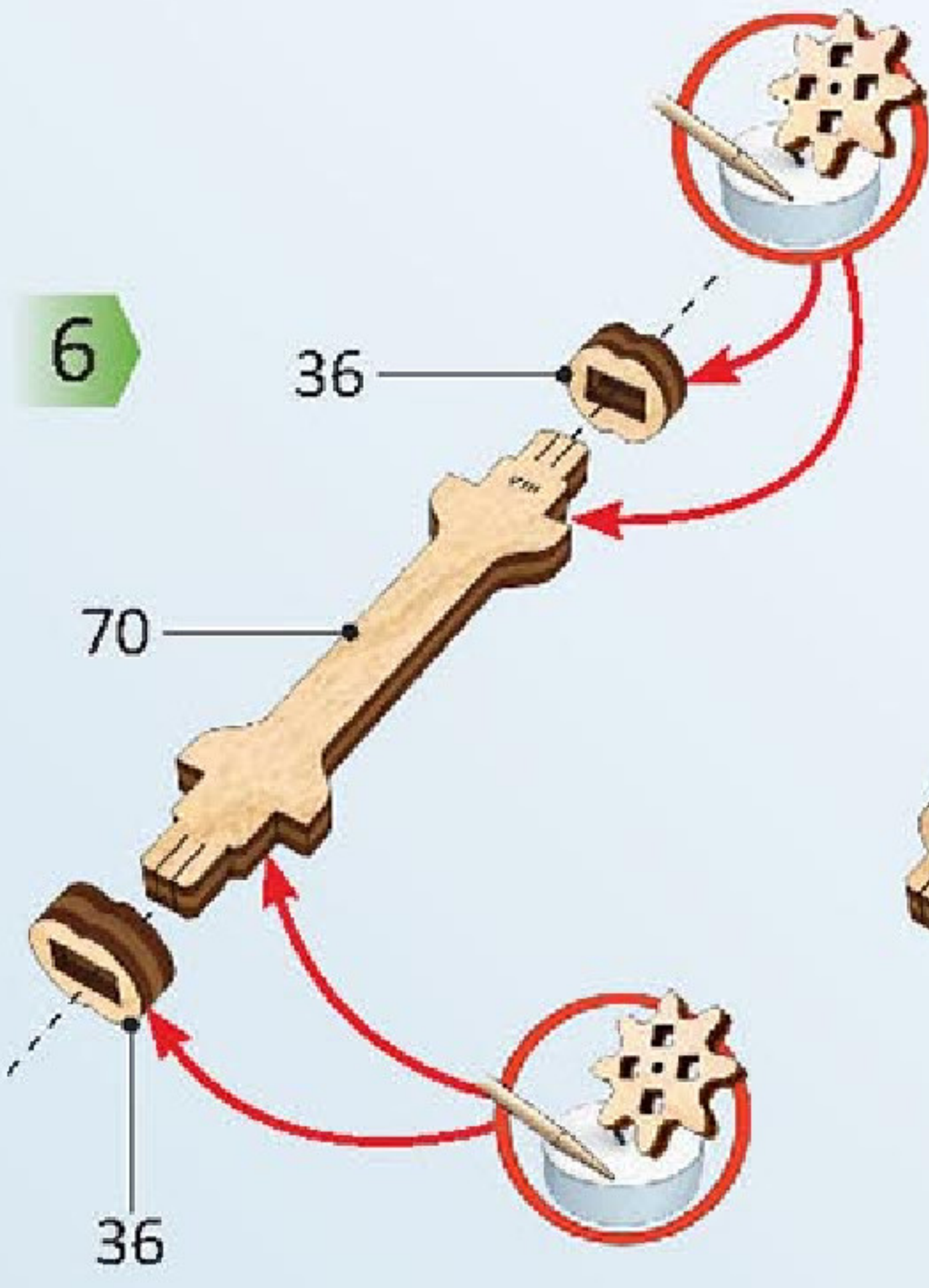

7



8

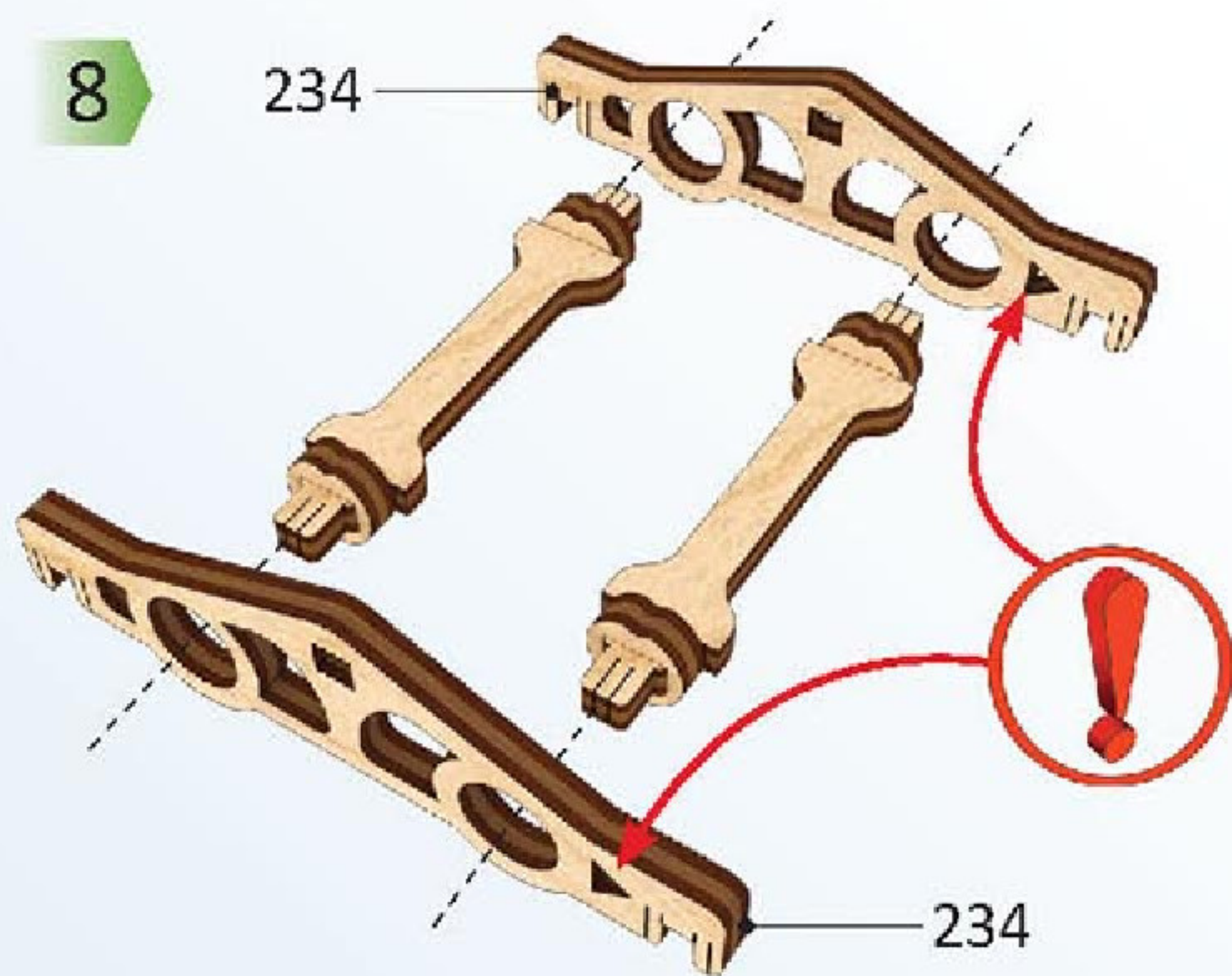

9

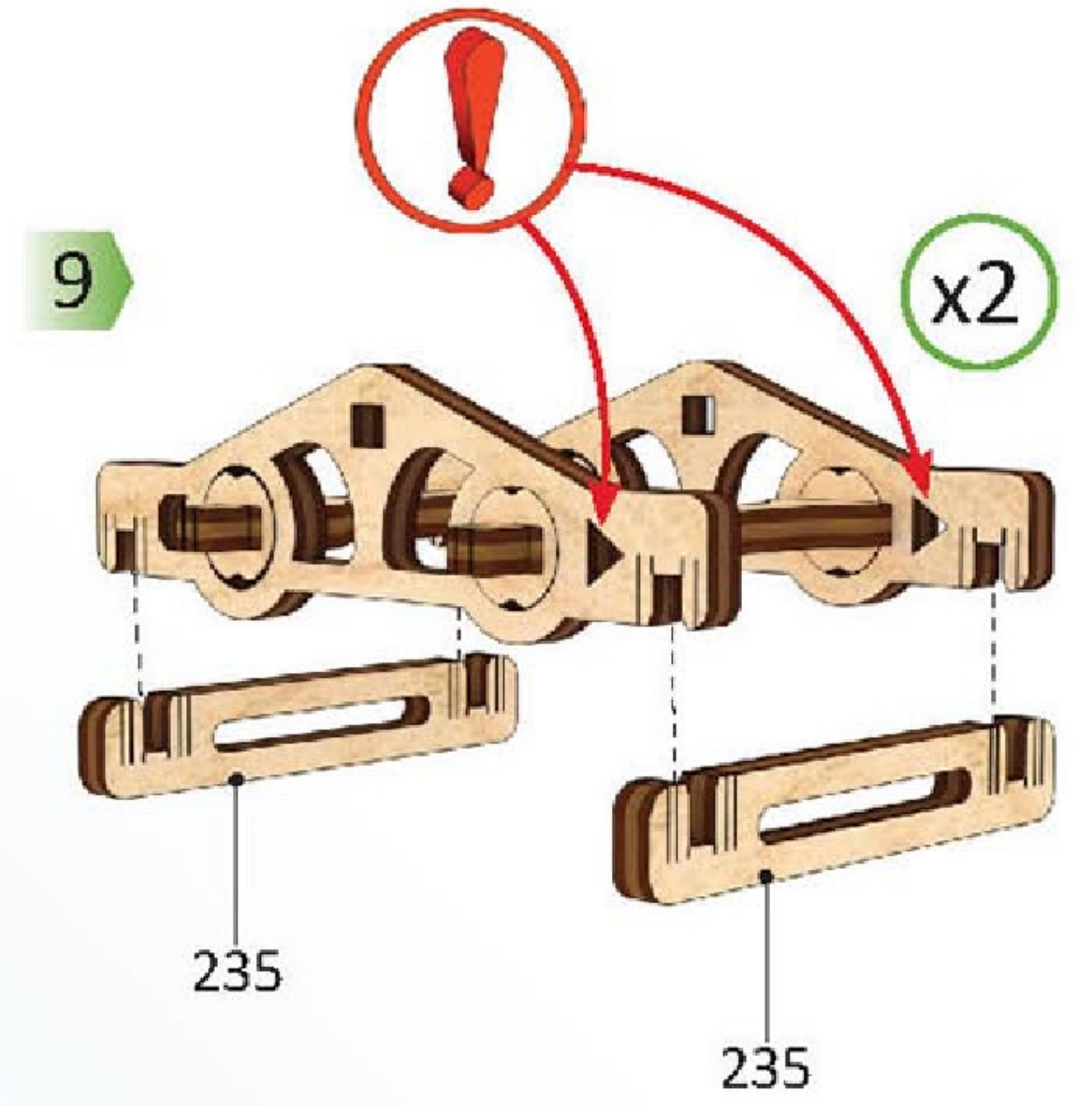

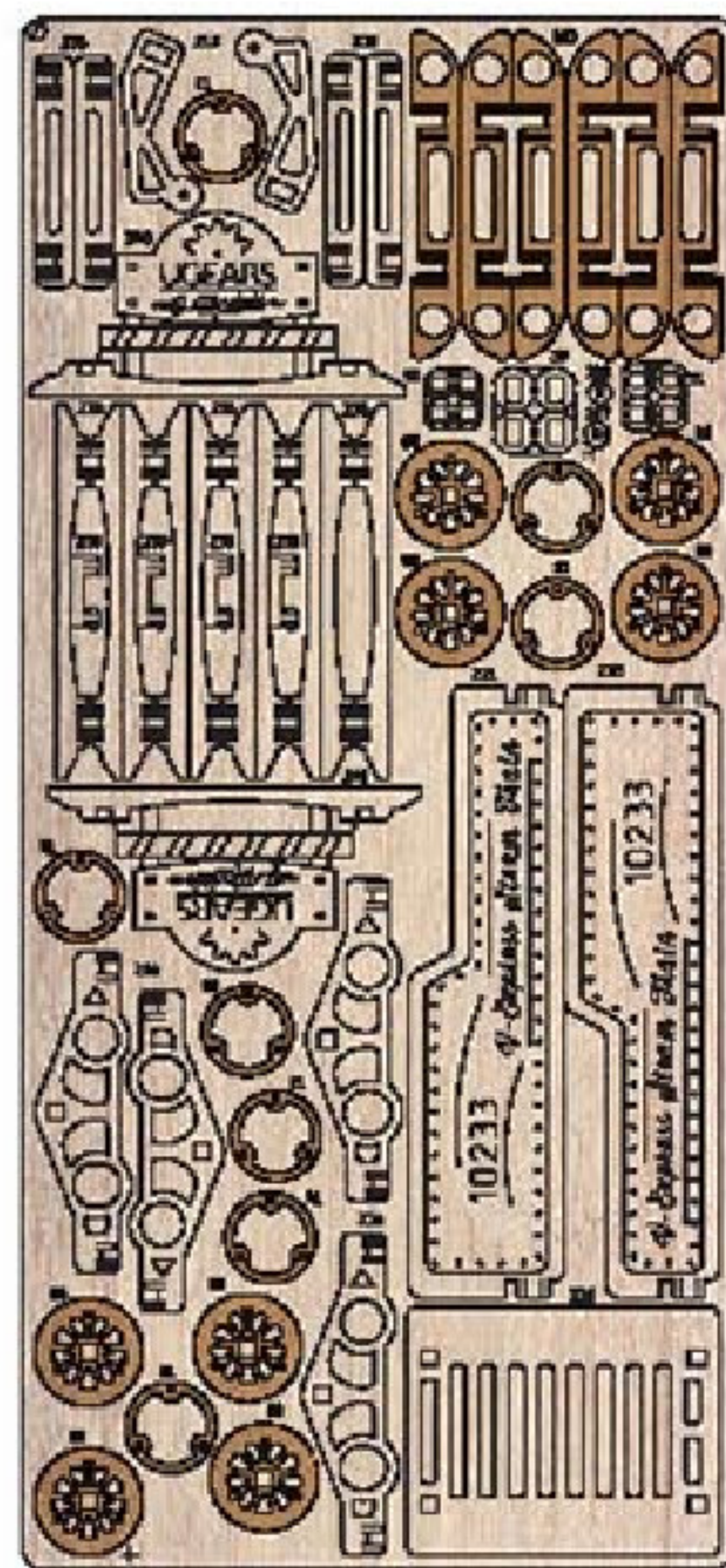

7

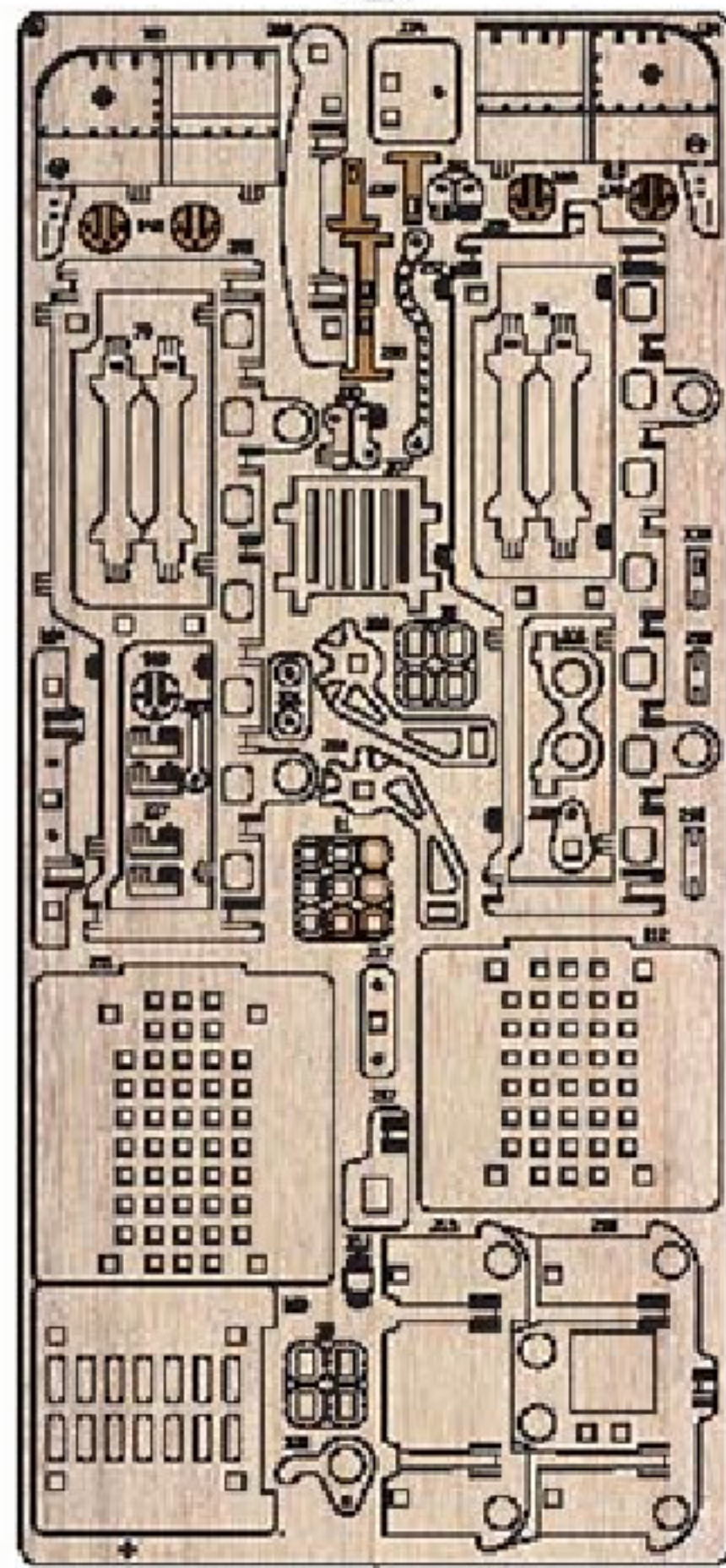

8

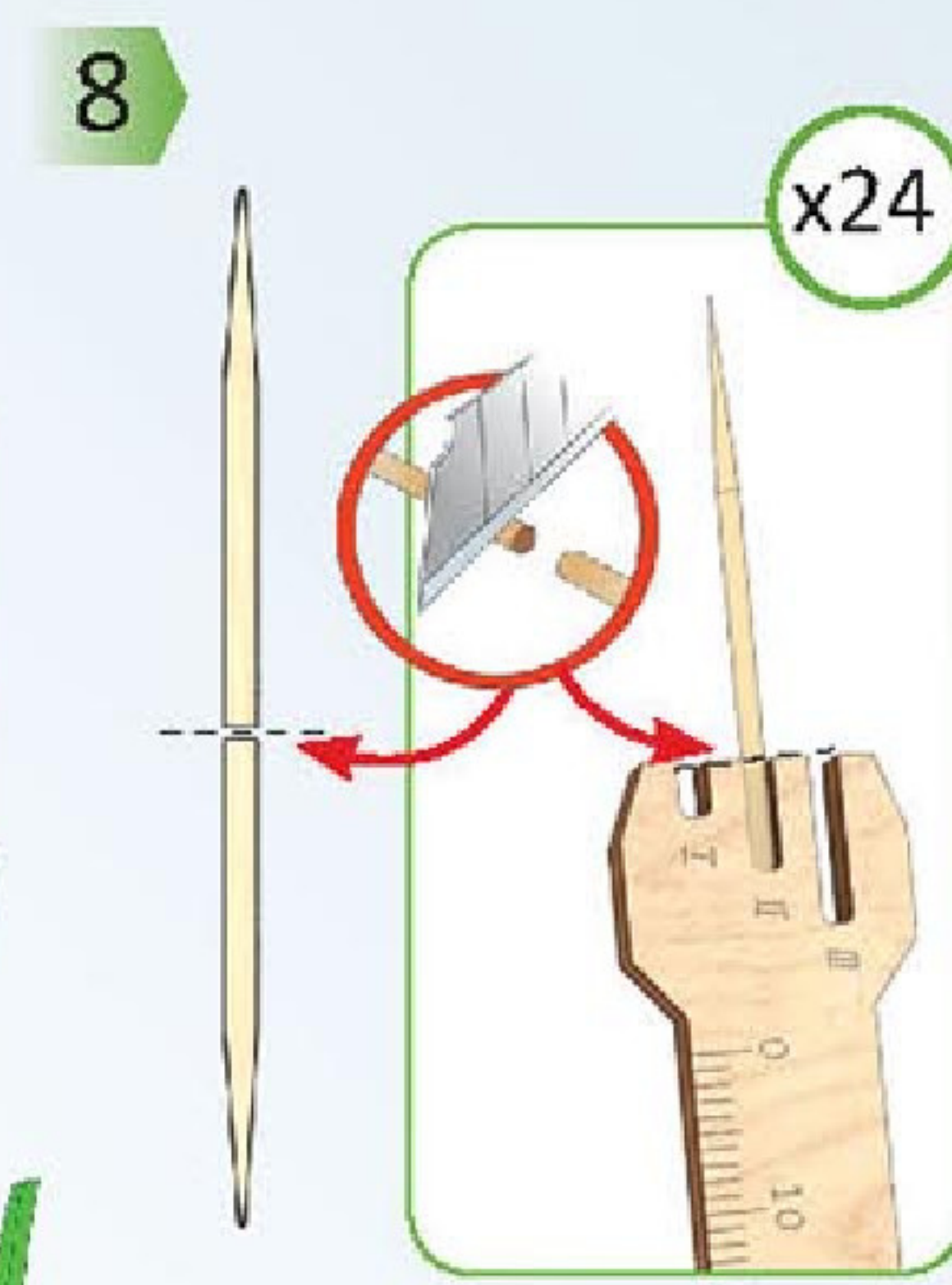
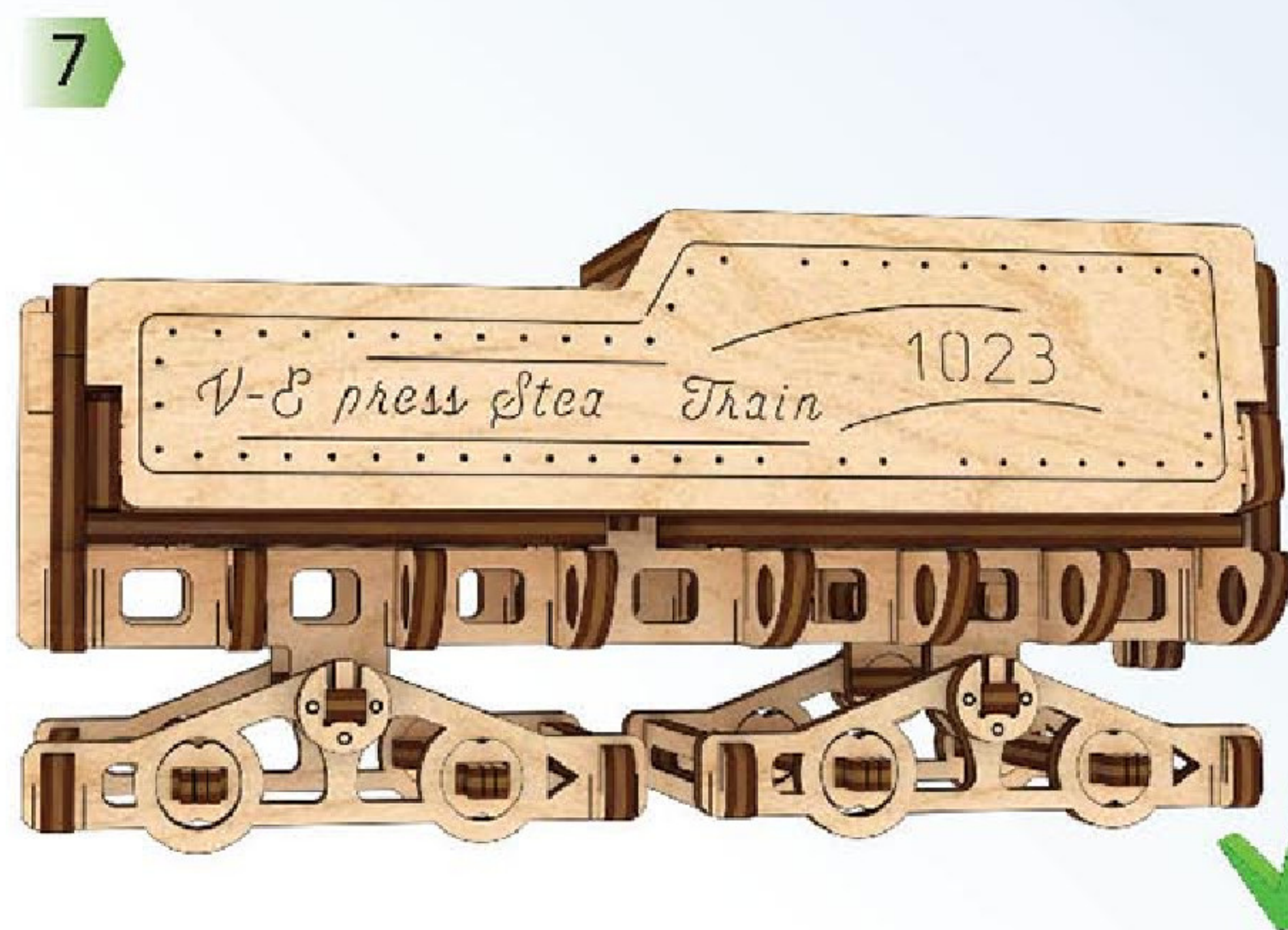
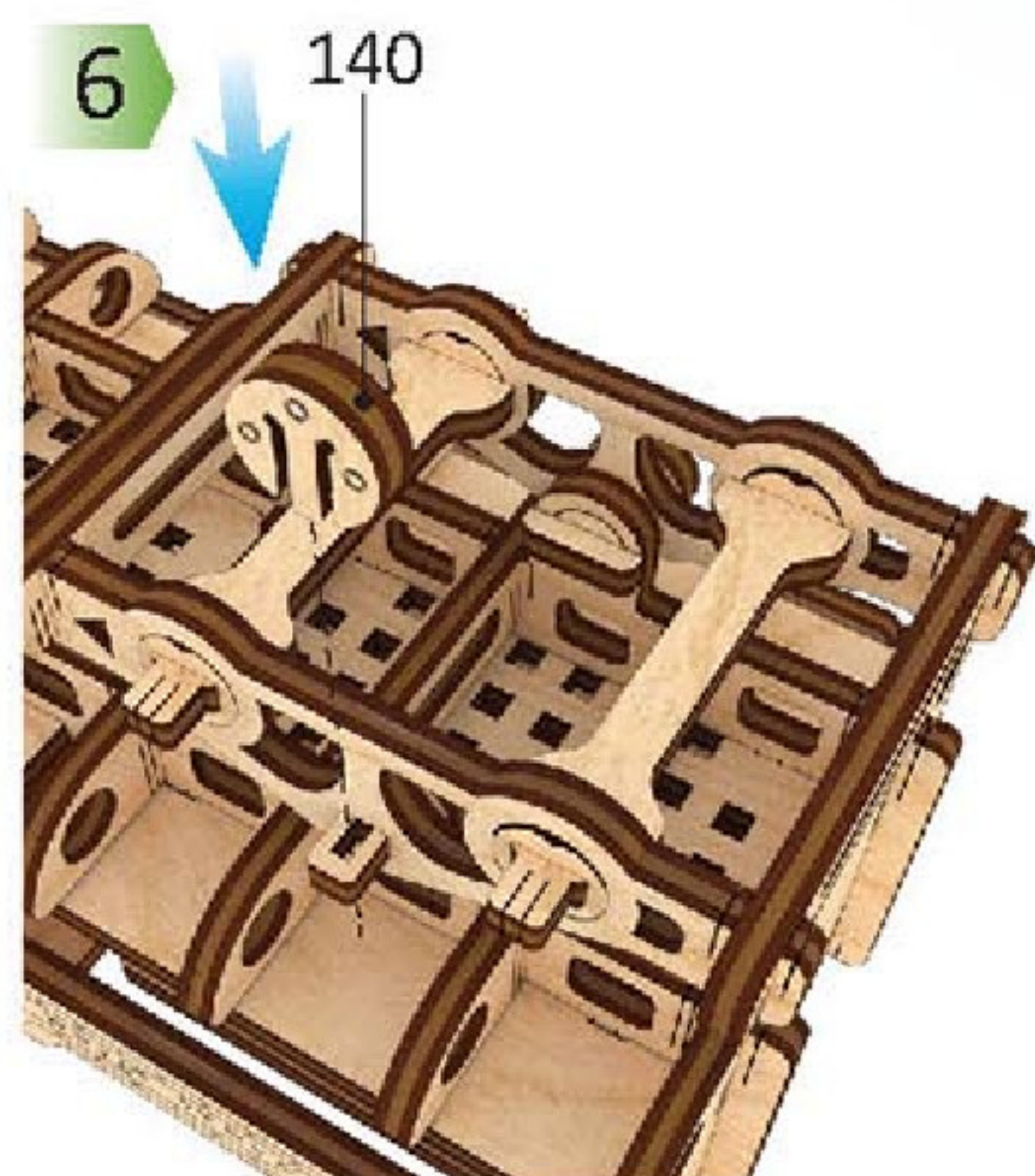
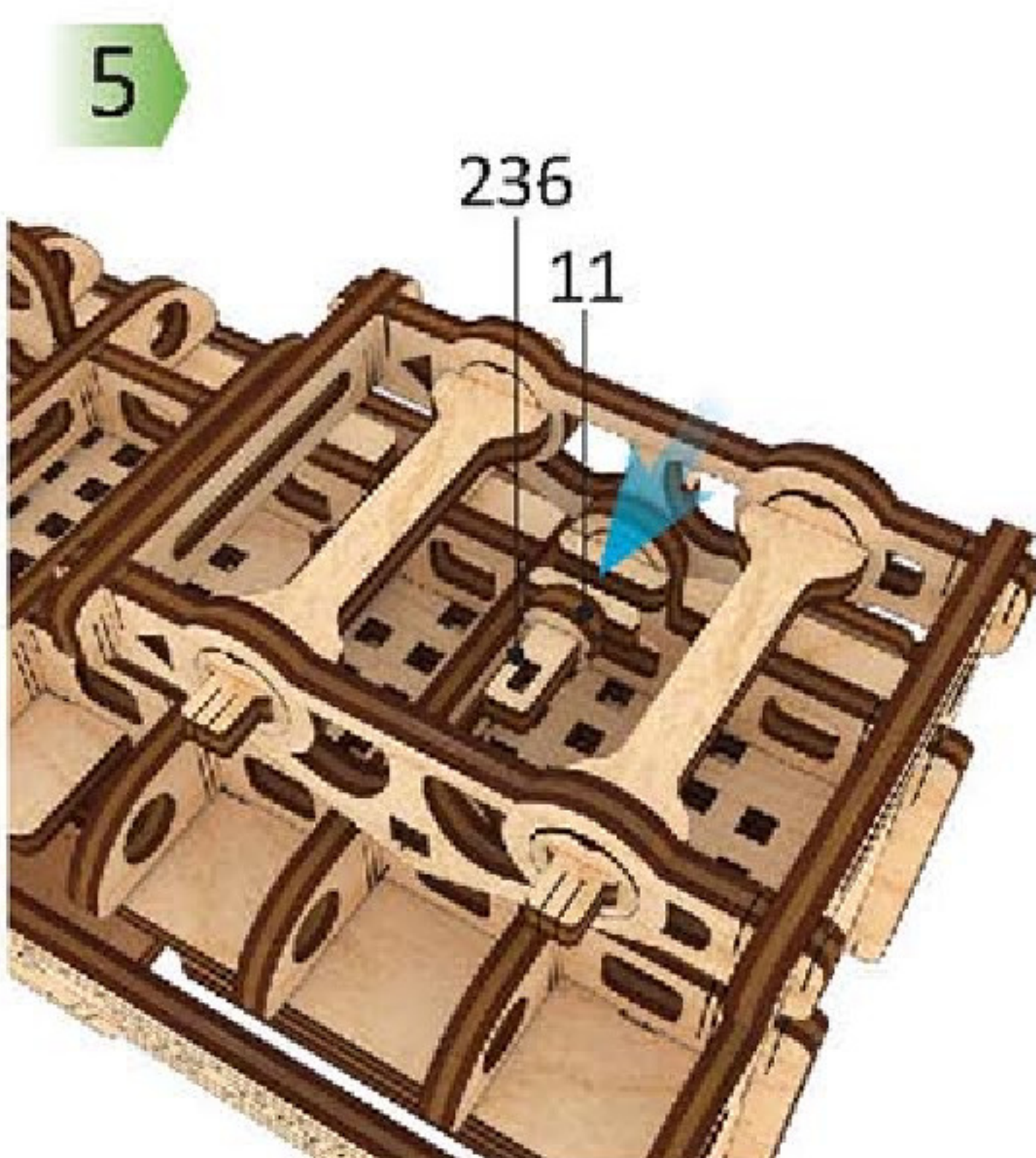
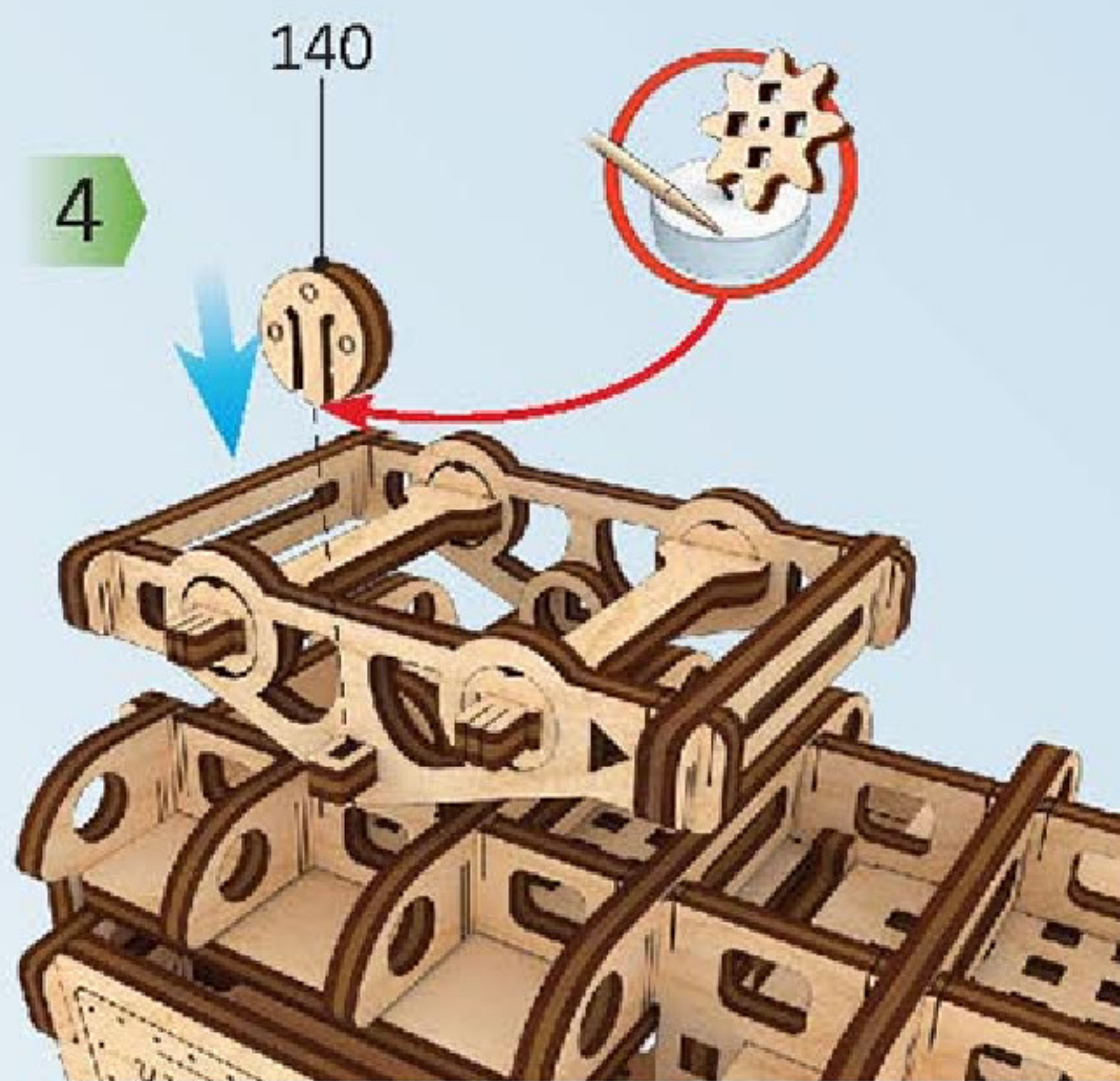
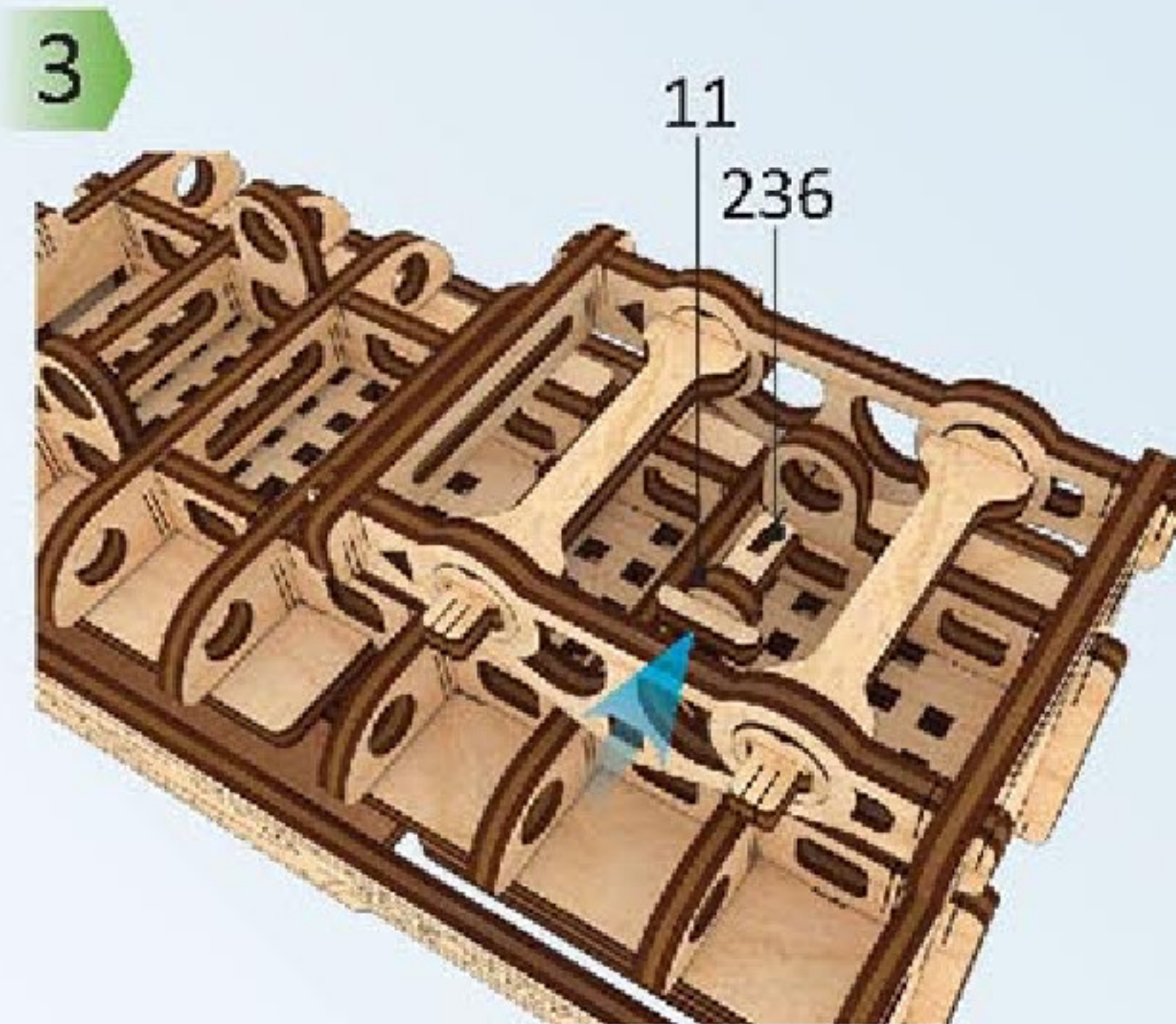
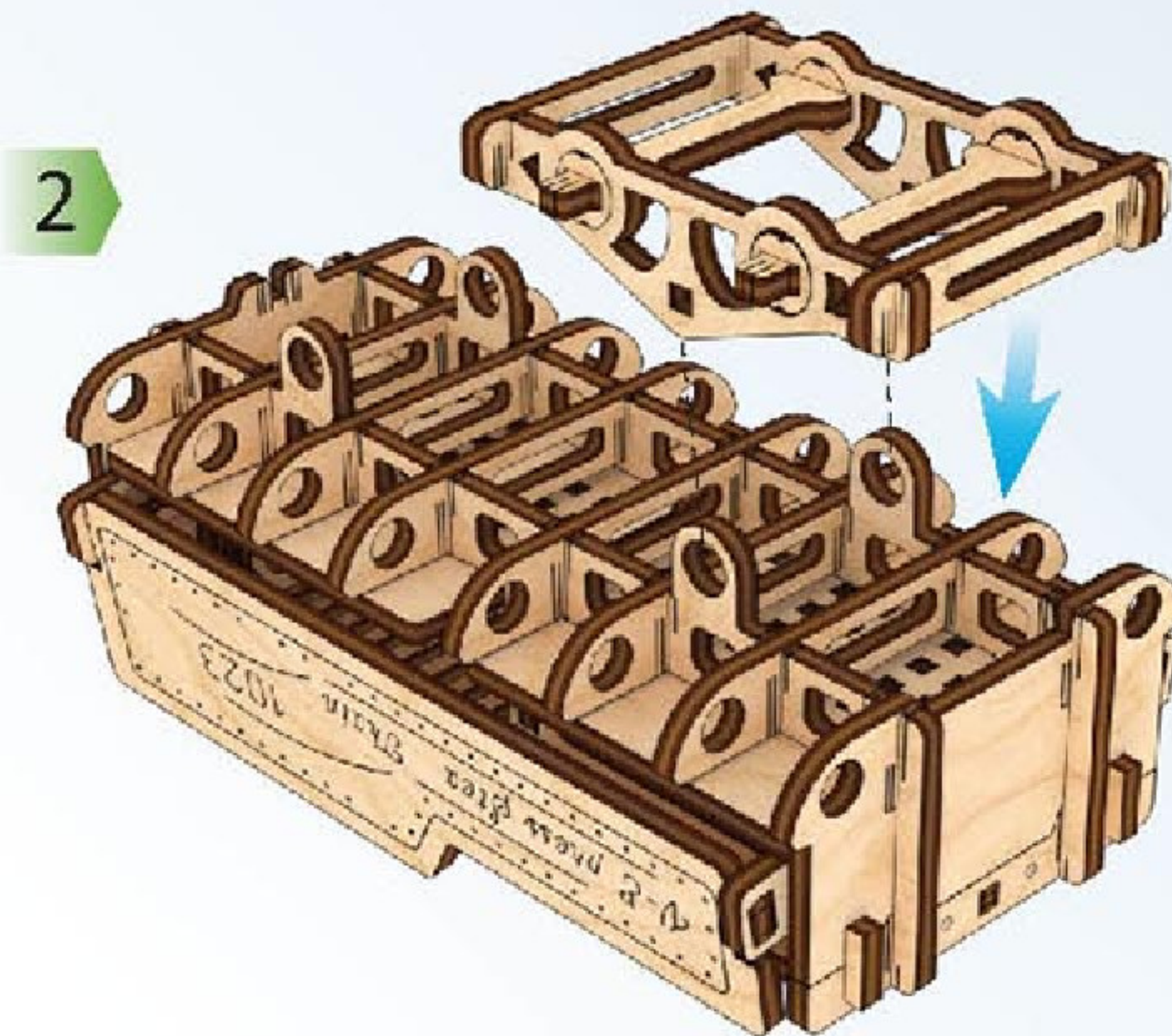
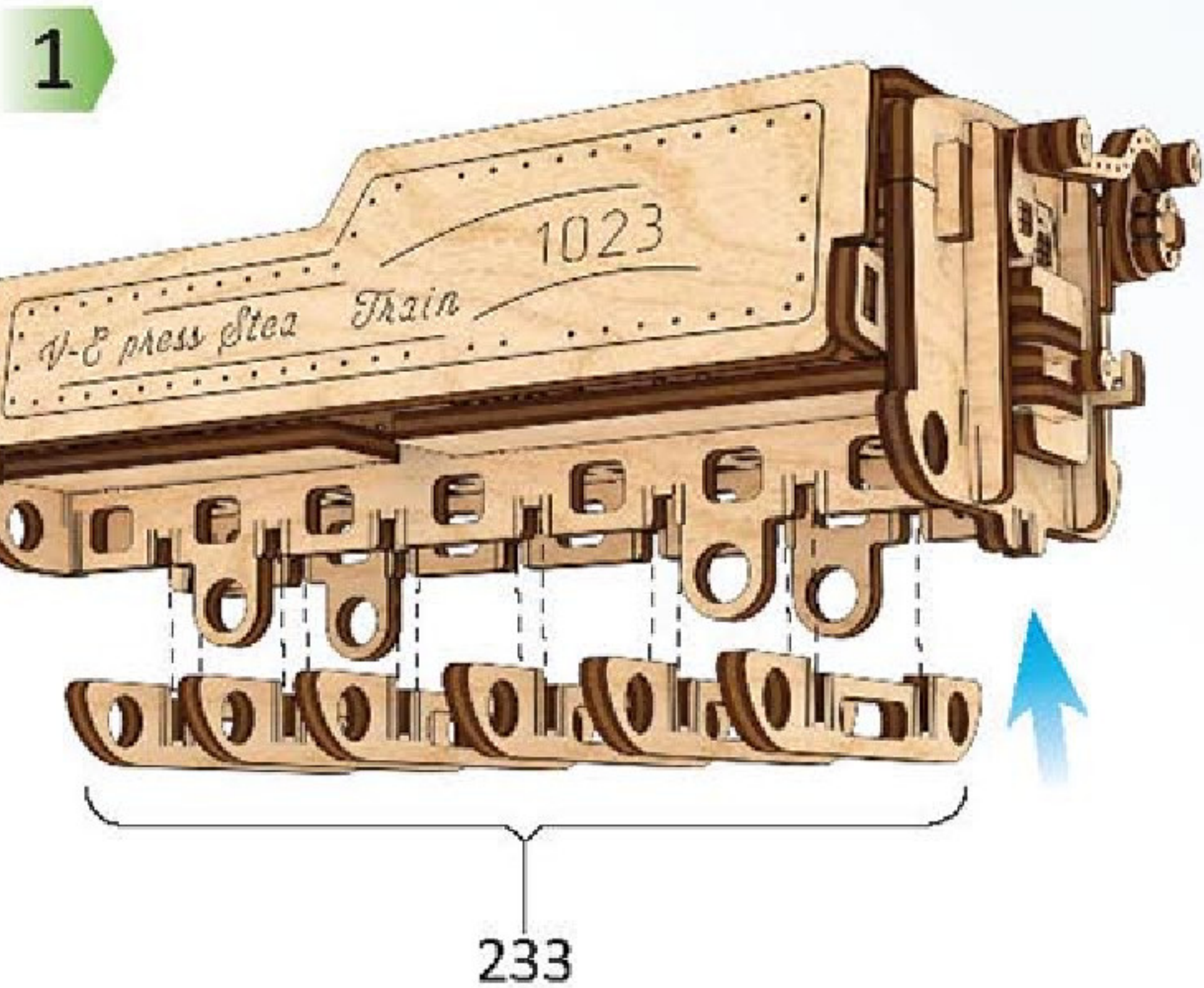

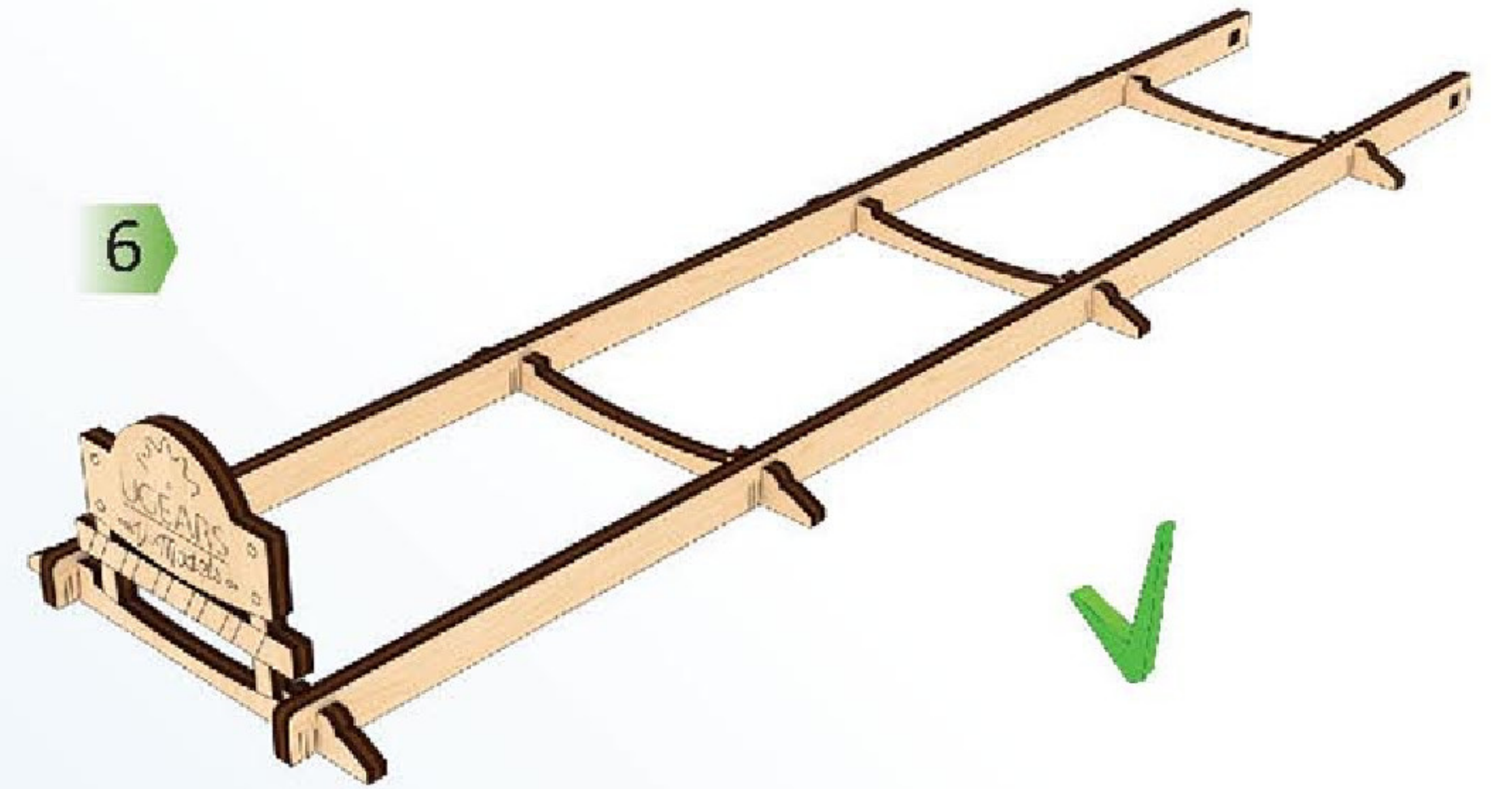
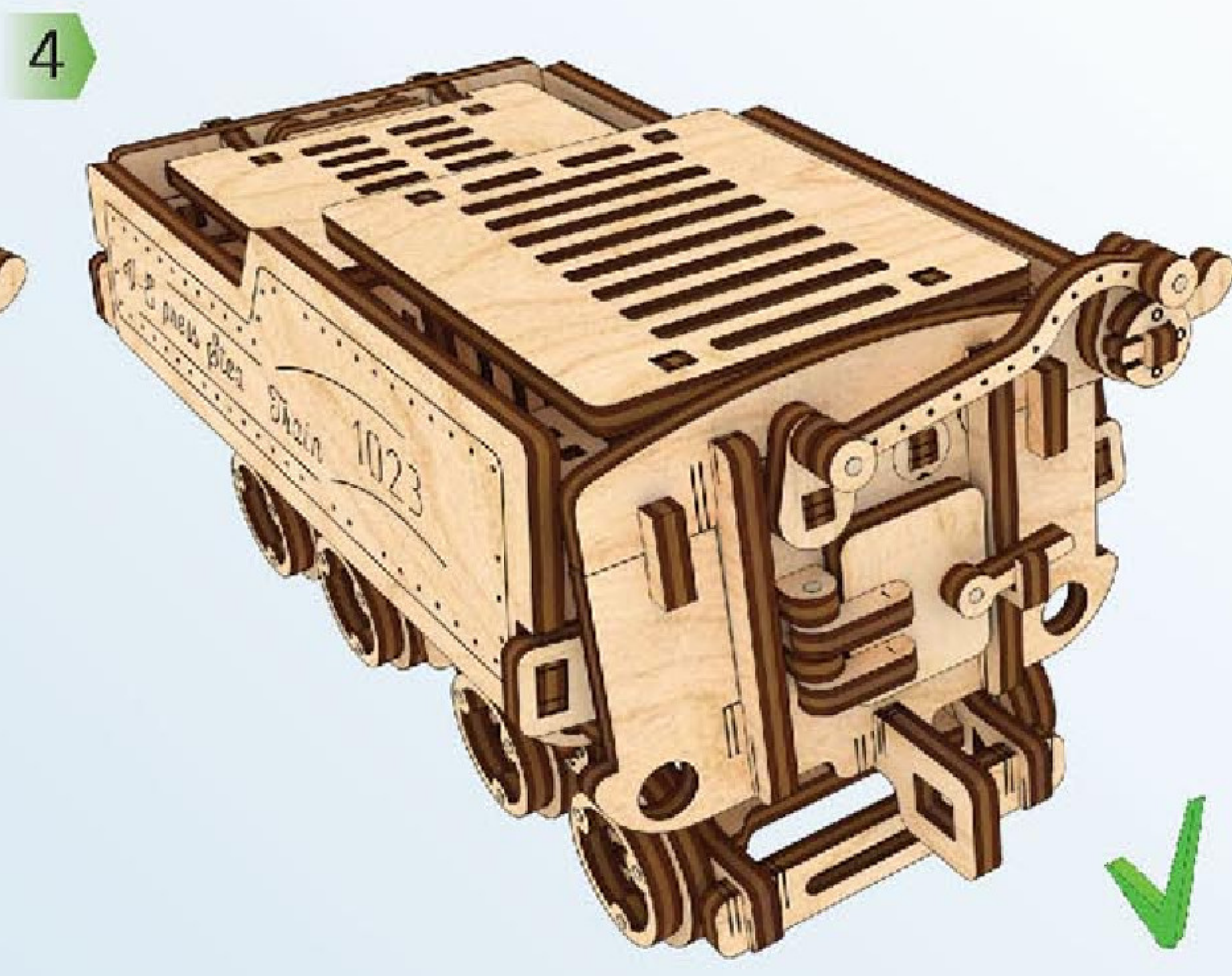
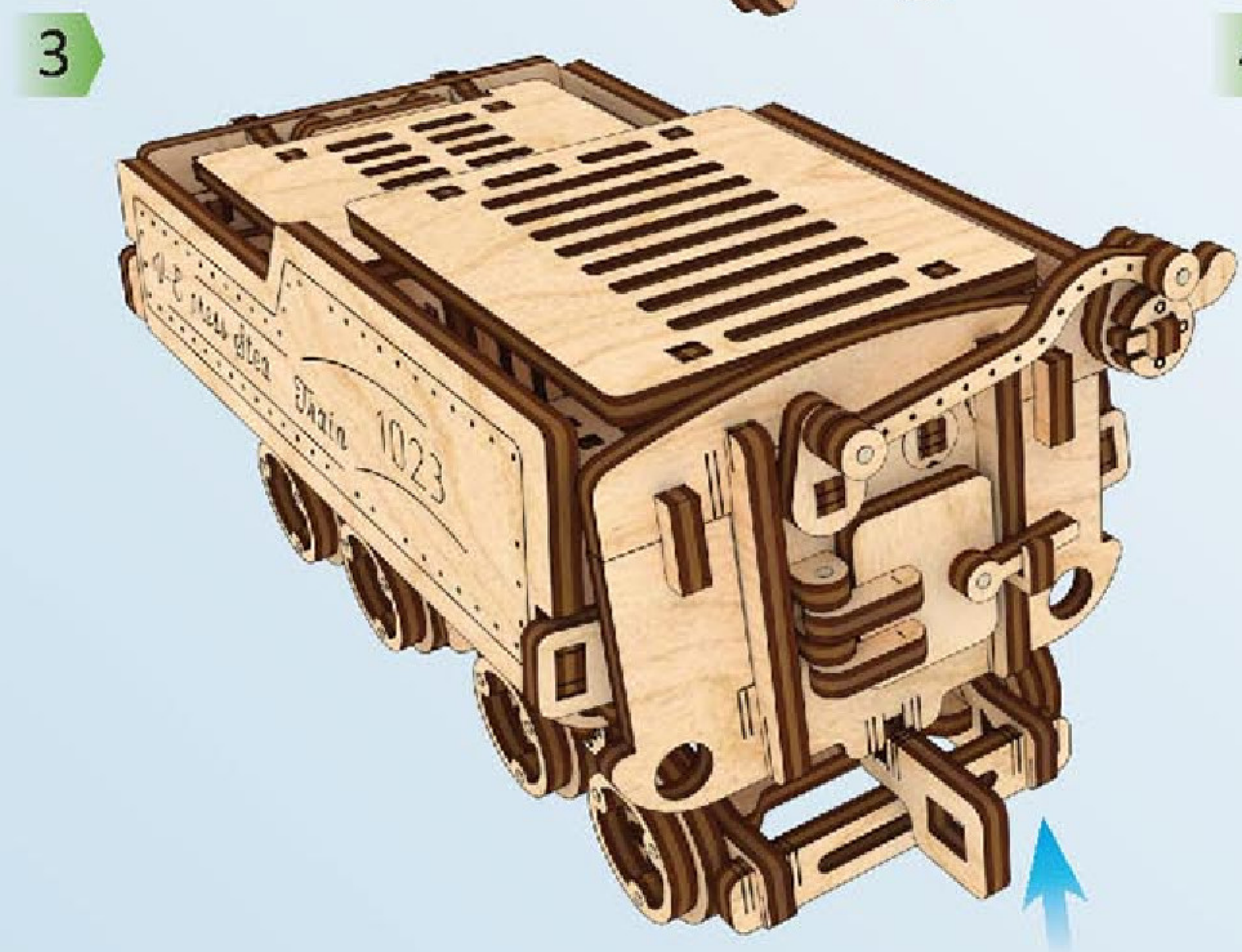
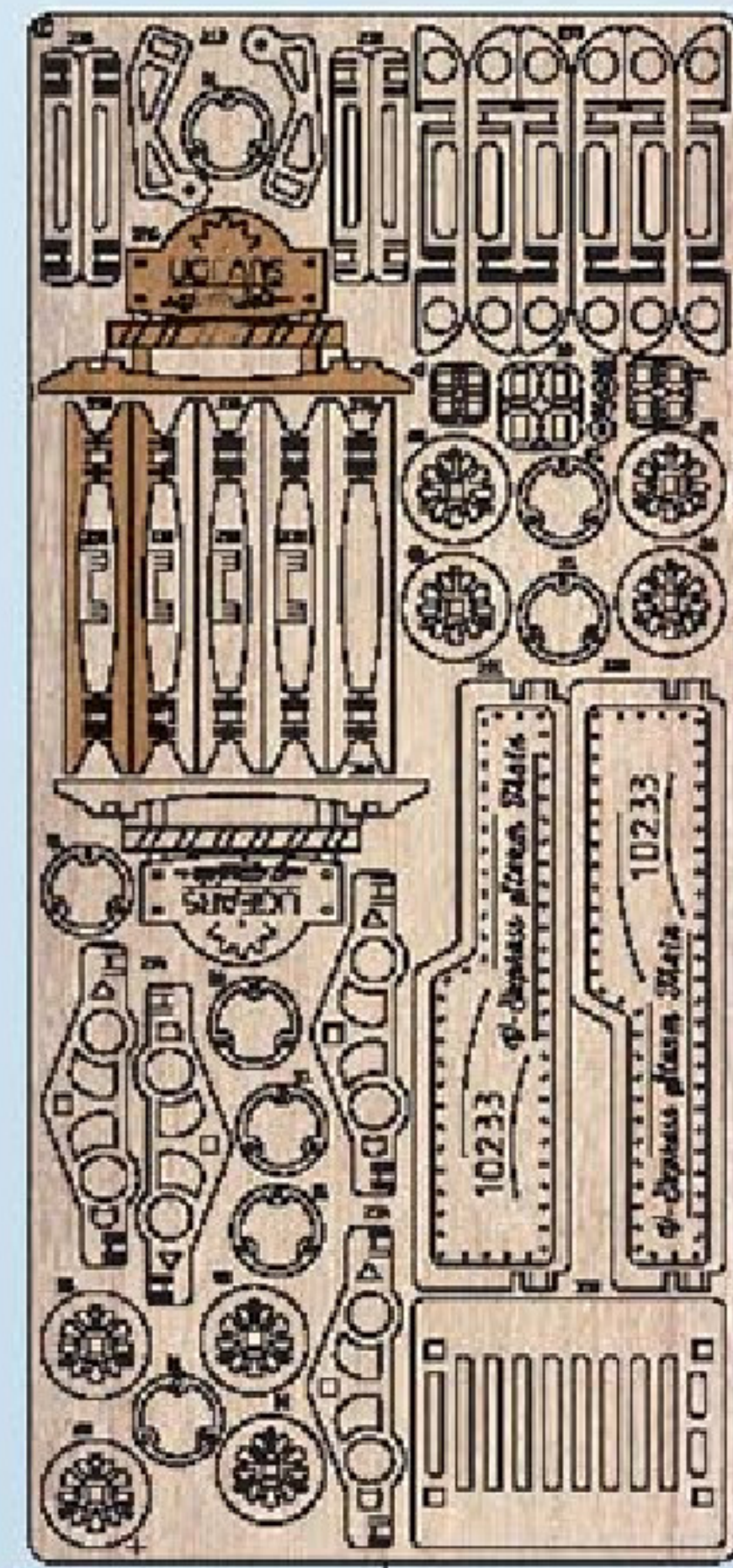
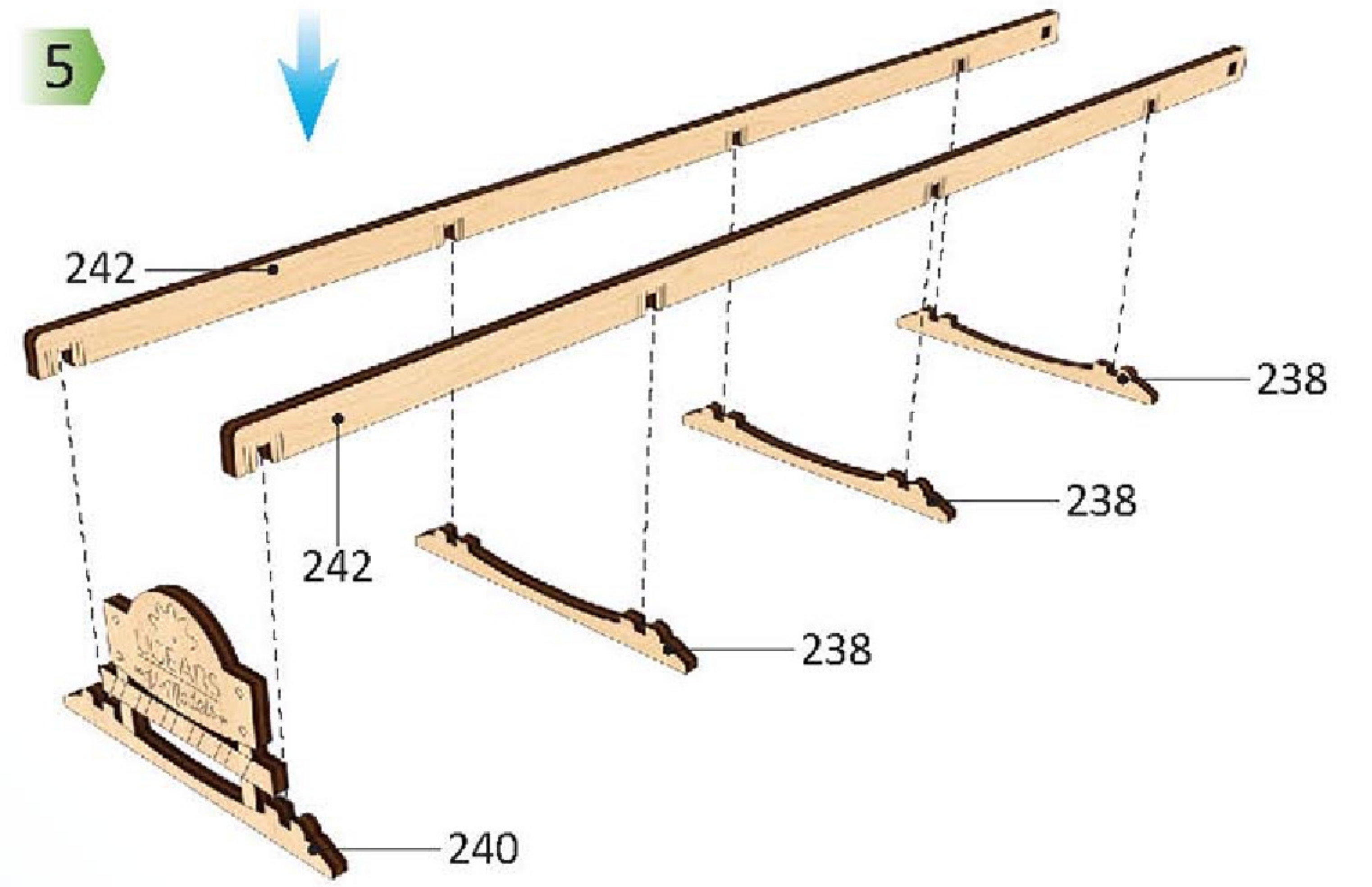
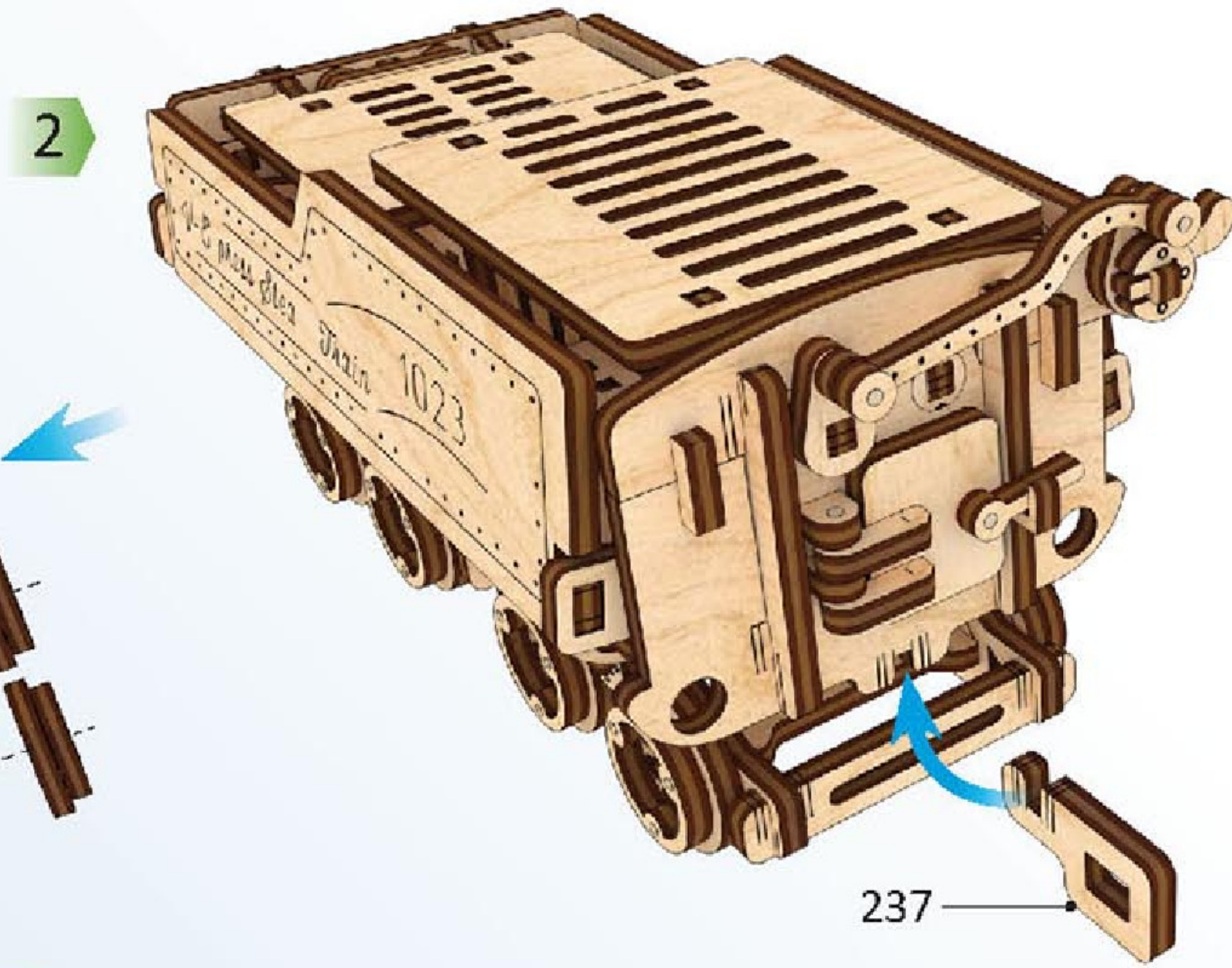
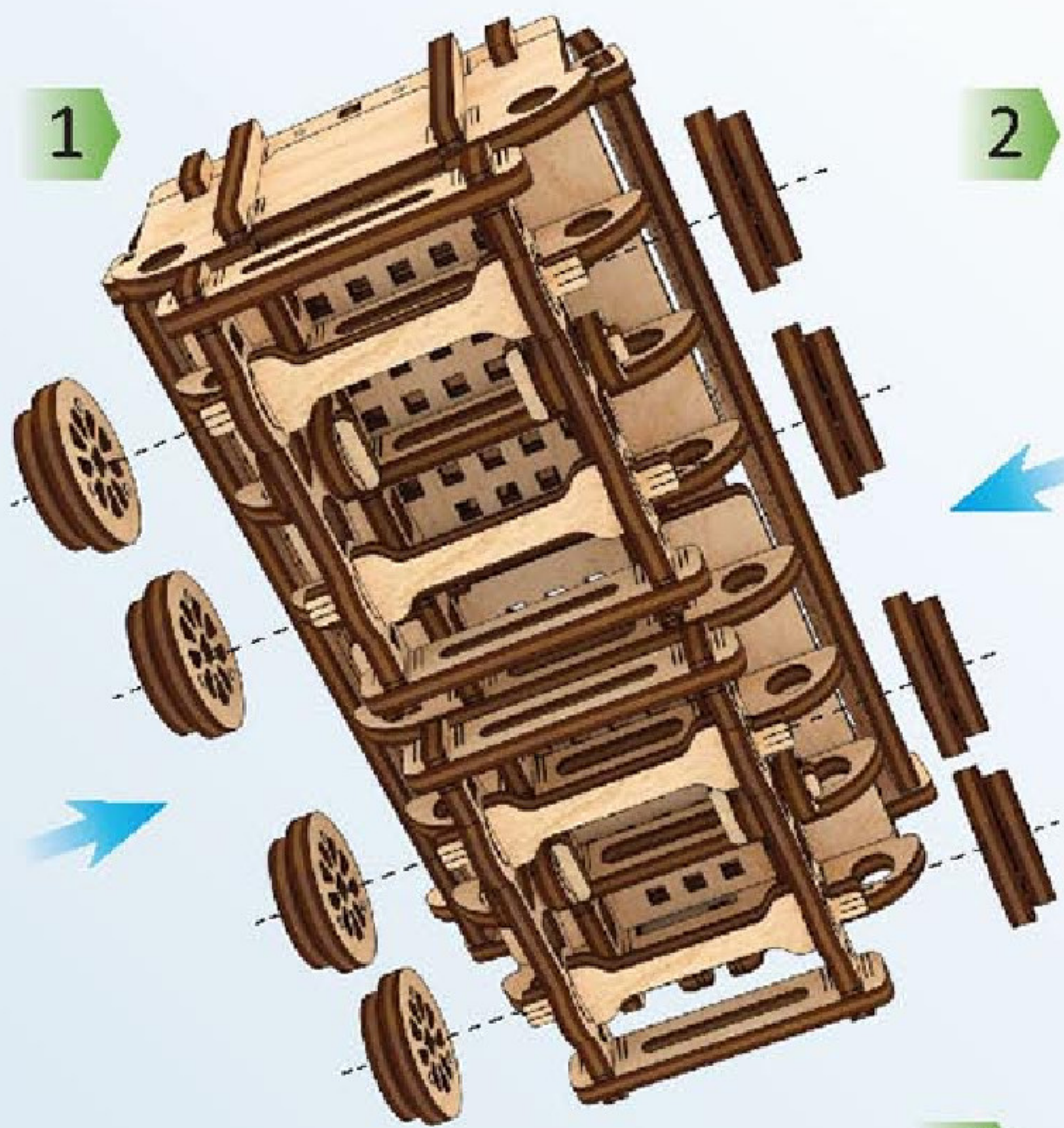
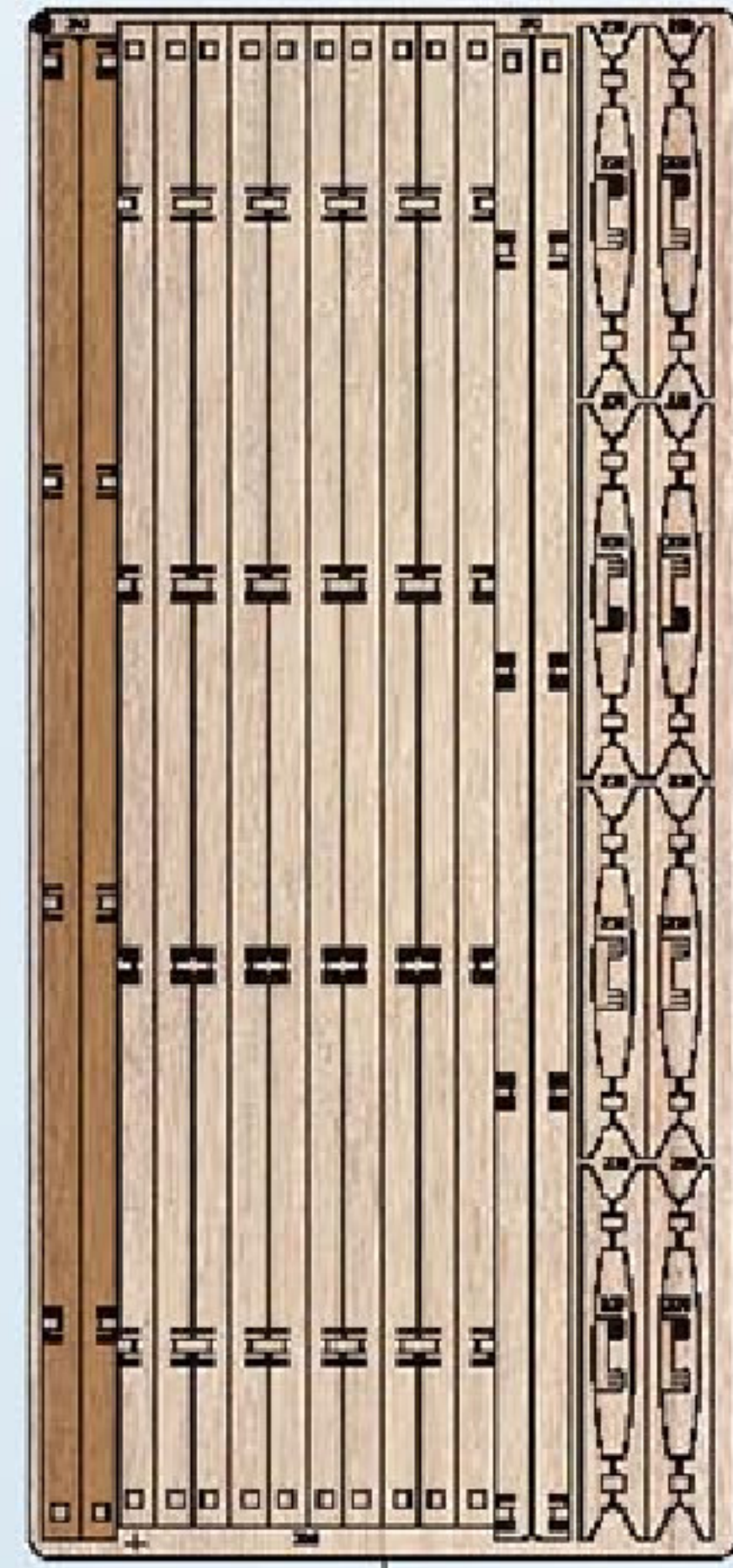
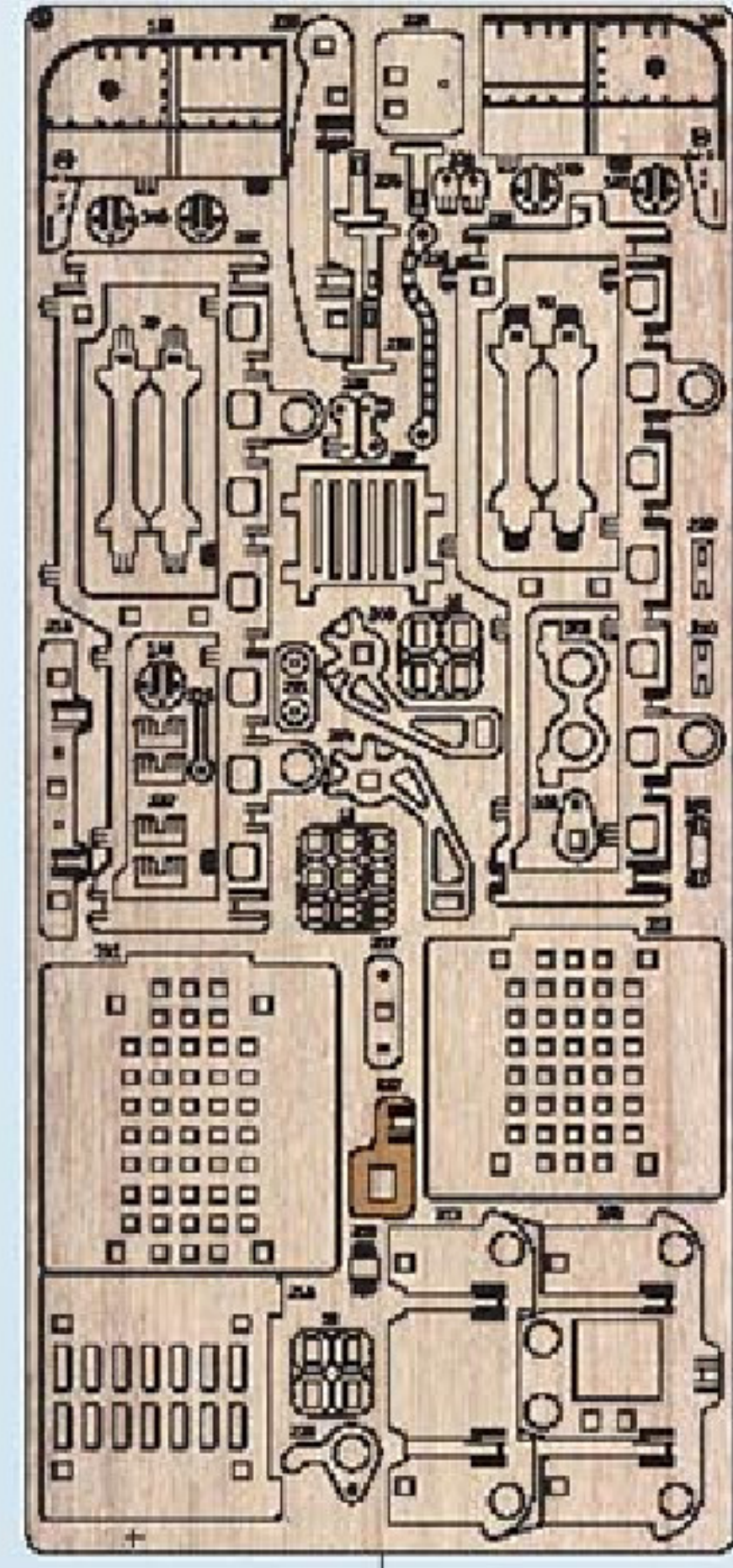

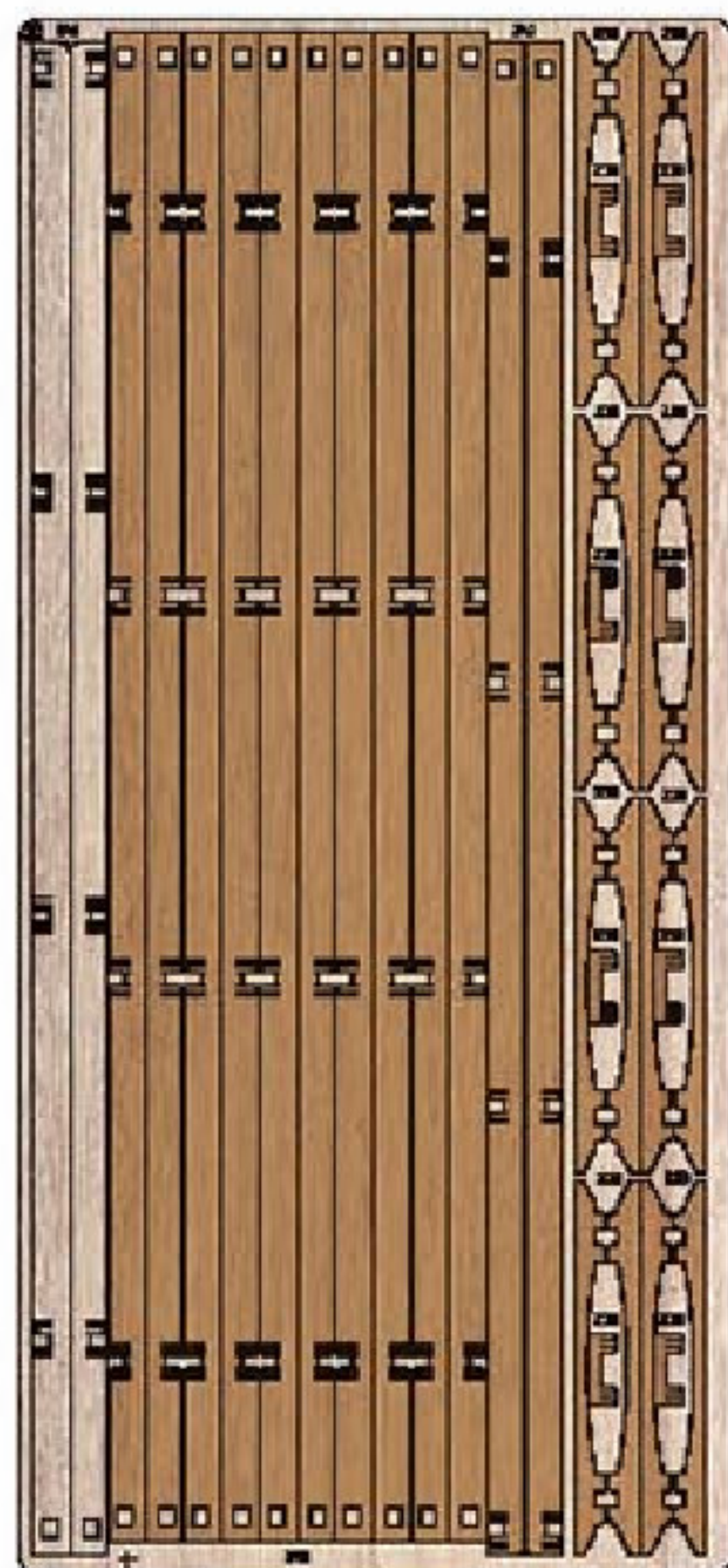

⊖

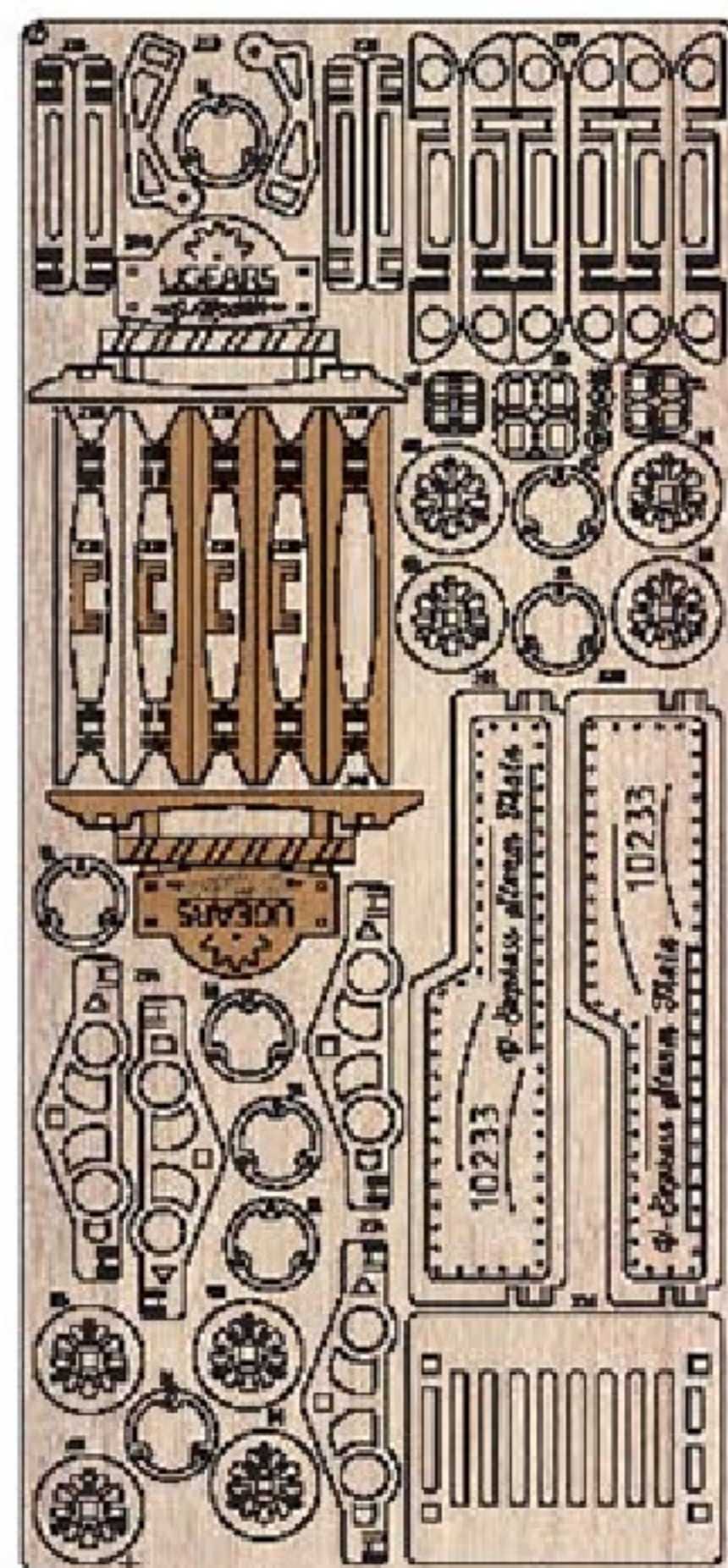

⊕

1

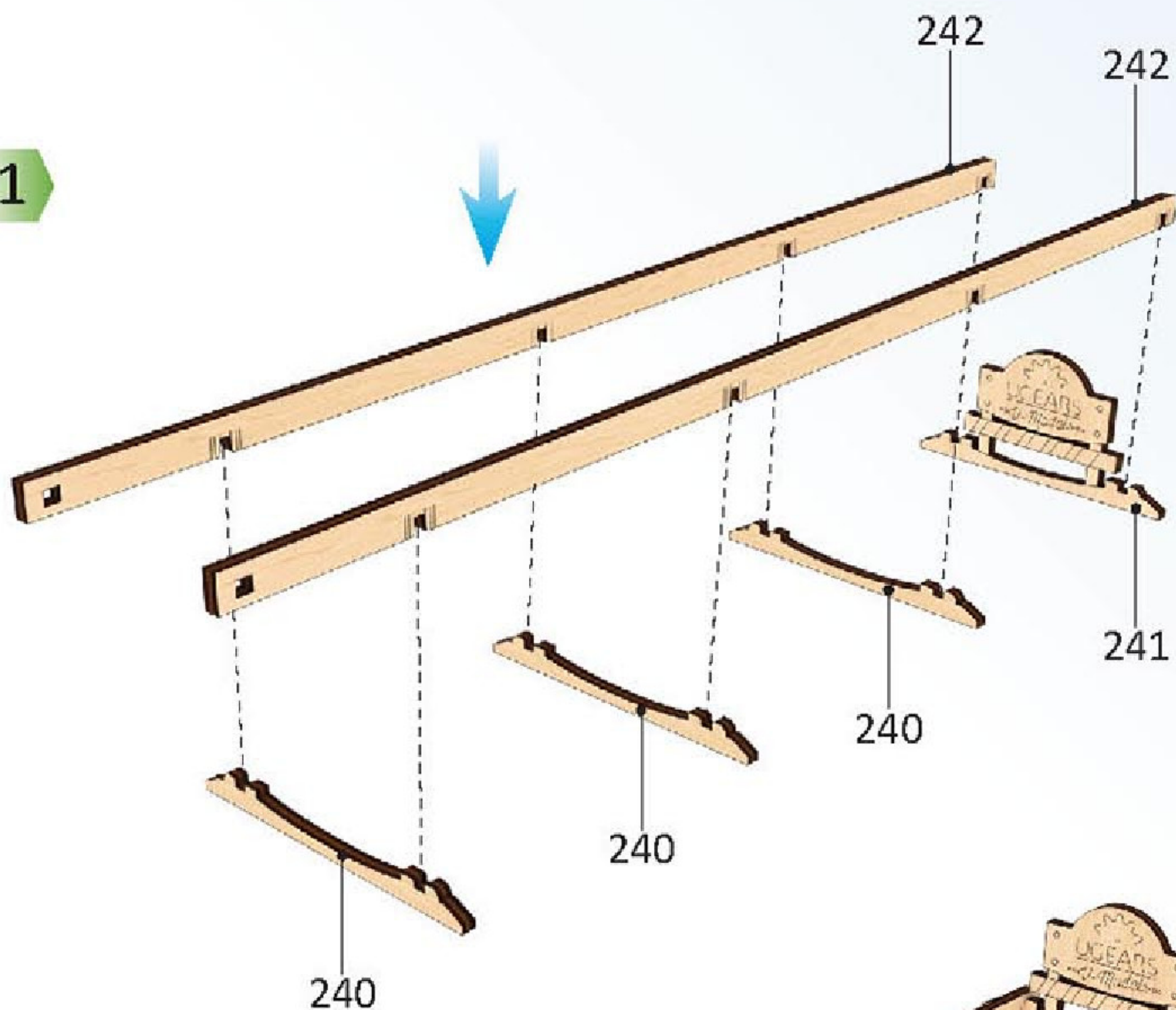

2

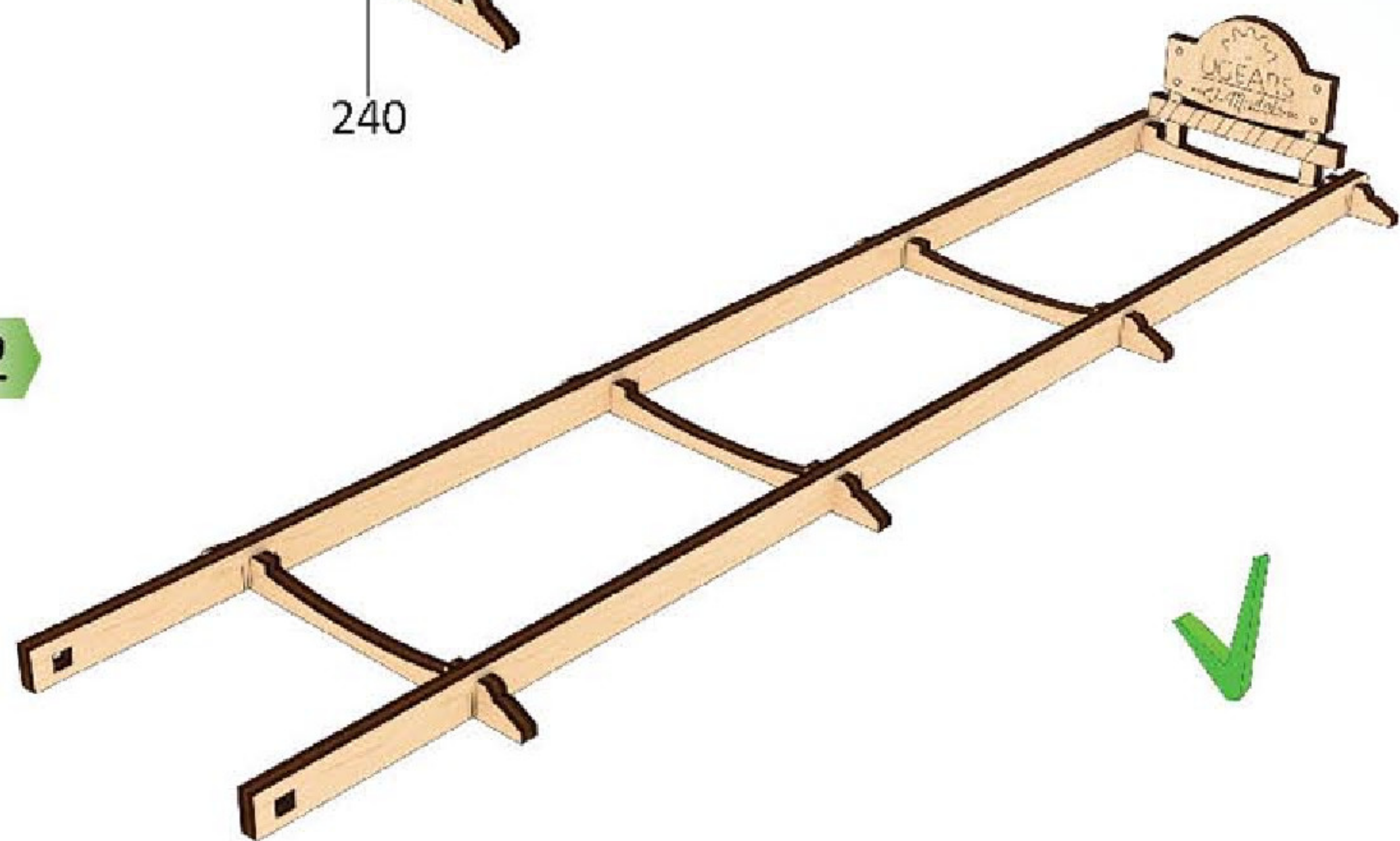

3

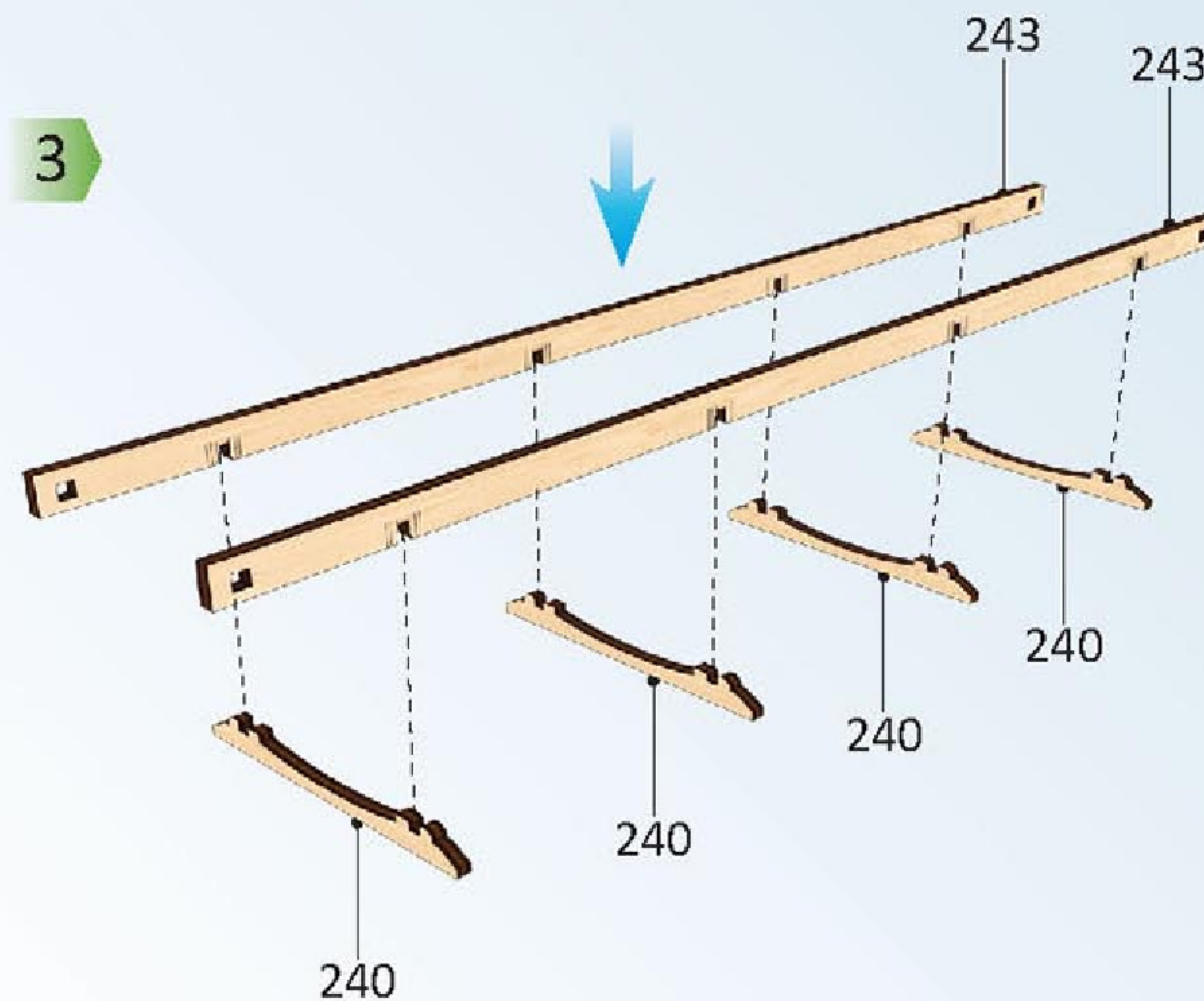

4

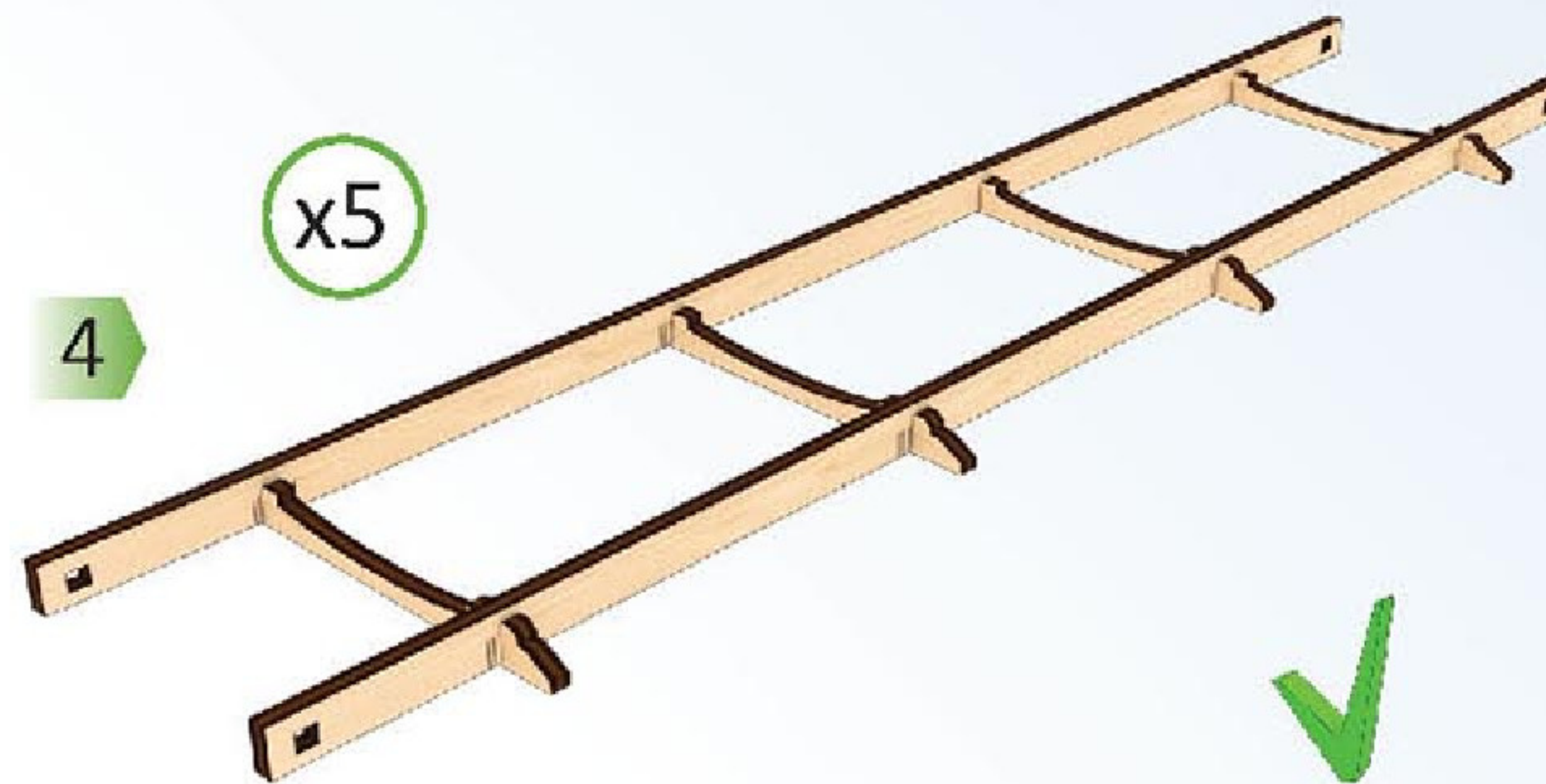

x5

5

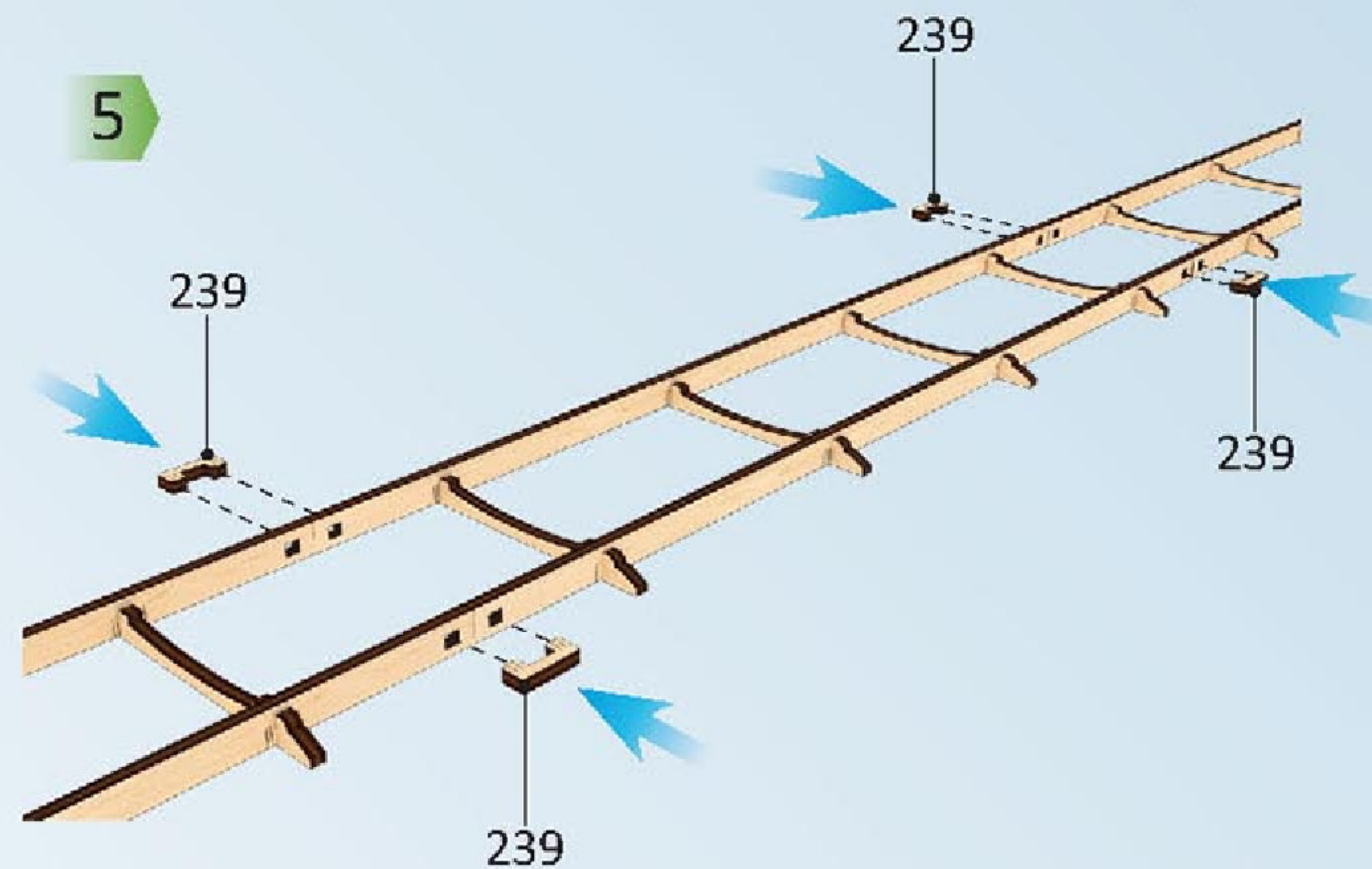

6

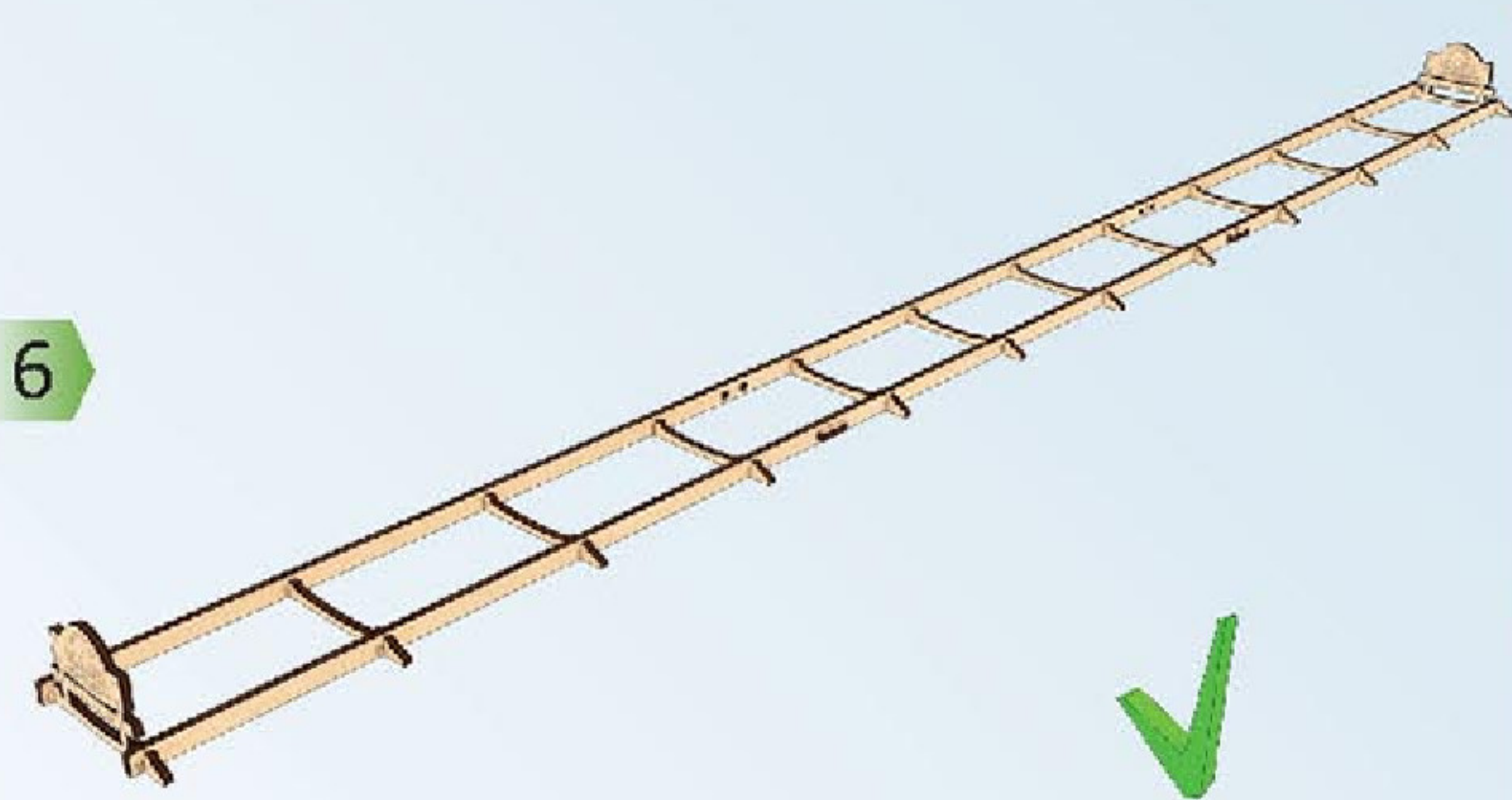

1

Vooruit rijden

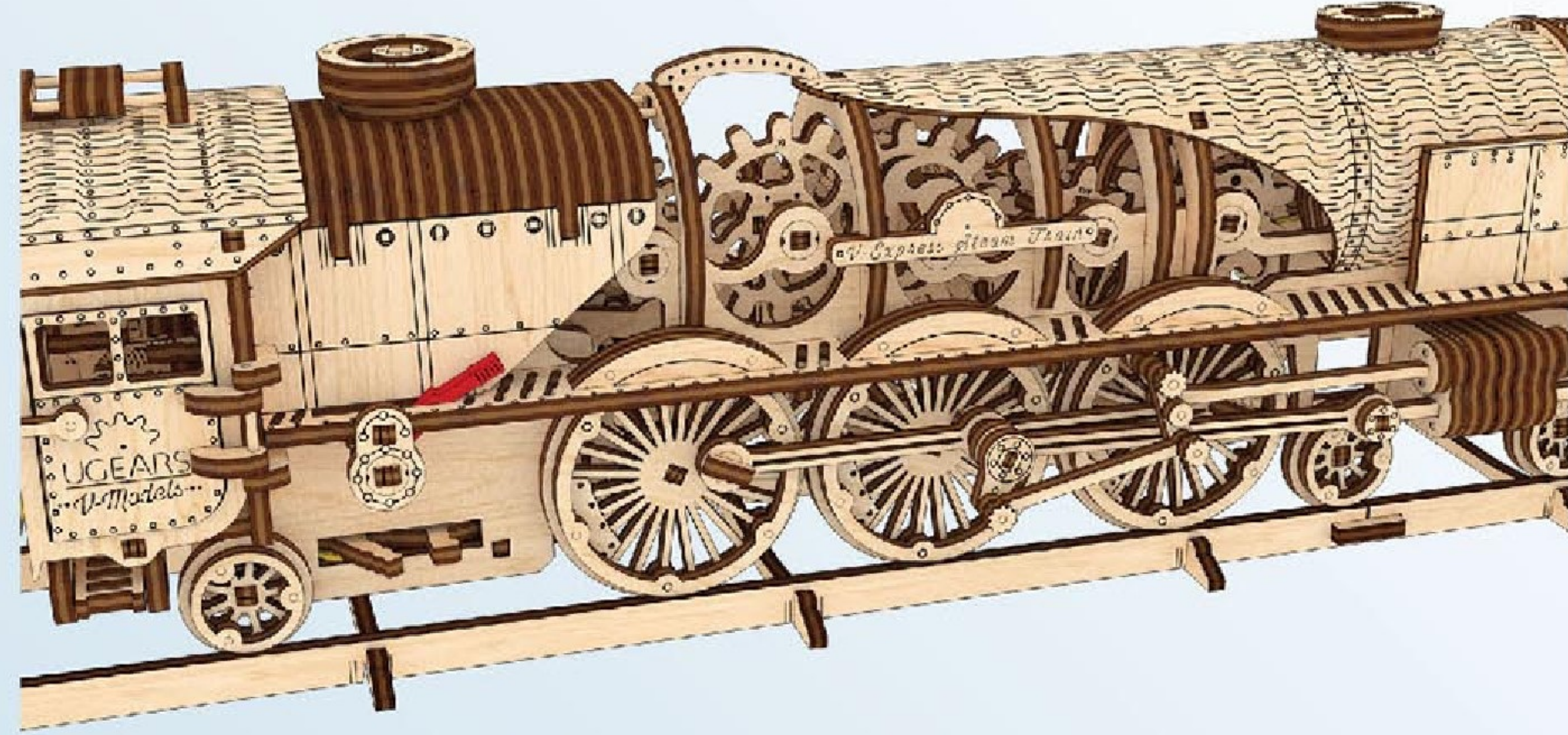

2

Neutraal

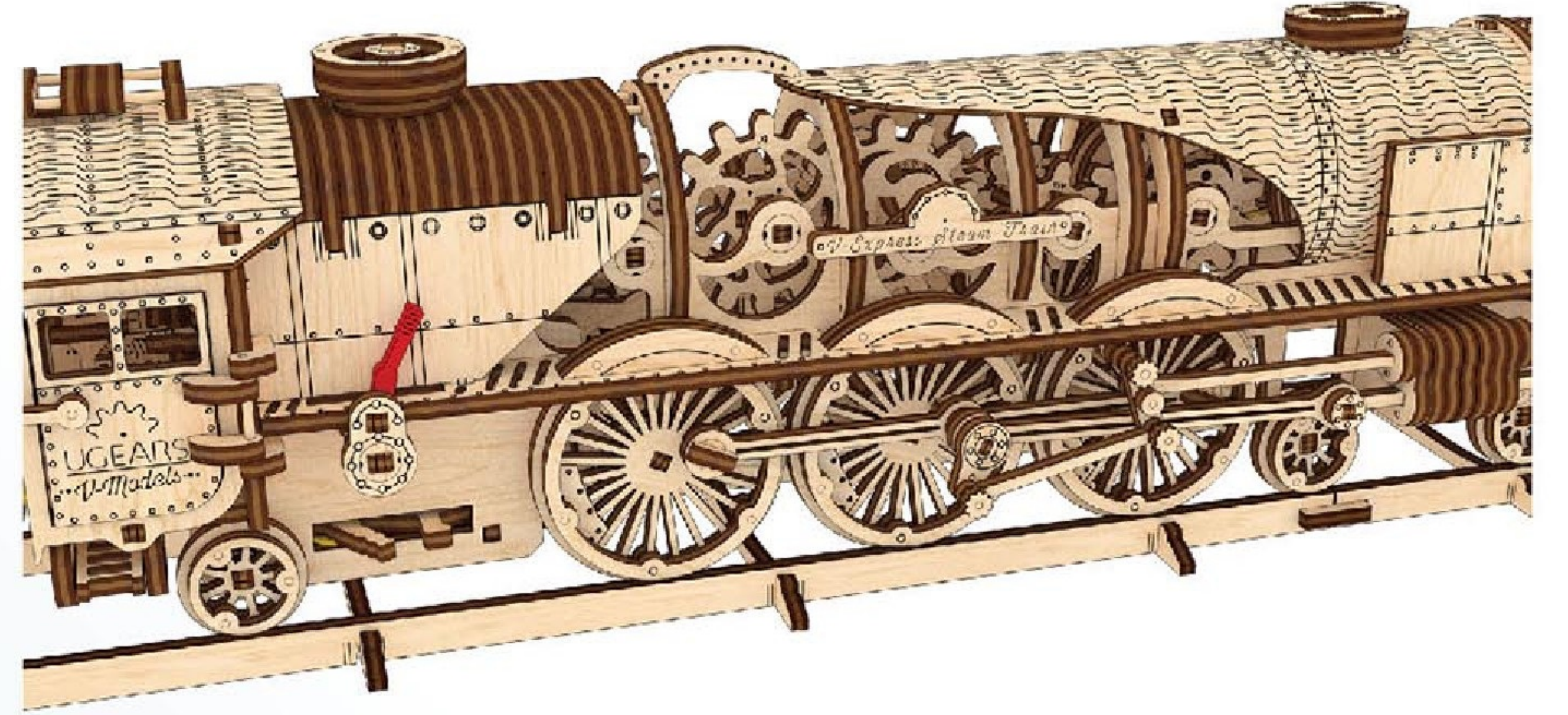

3

Achteruit rijden

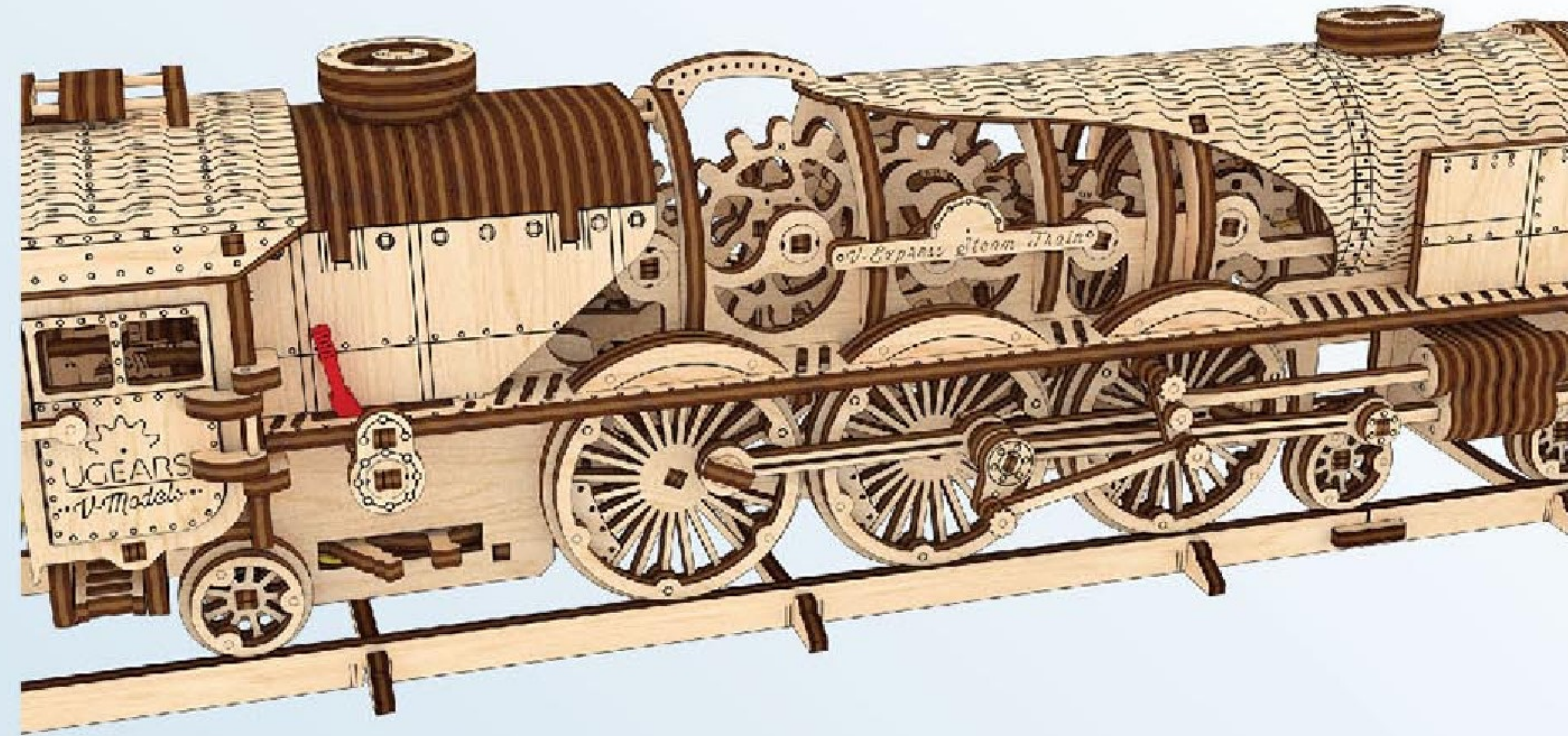



1

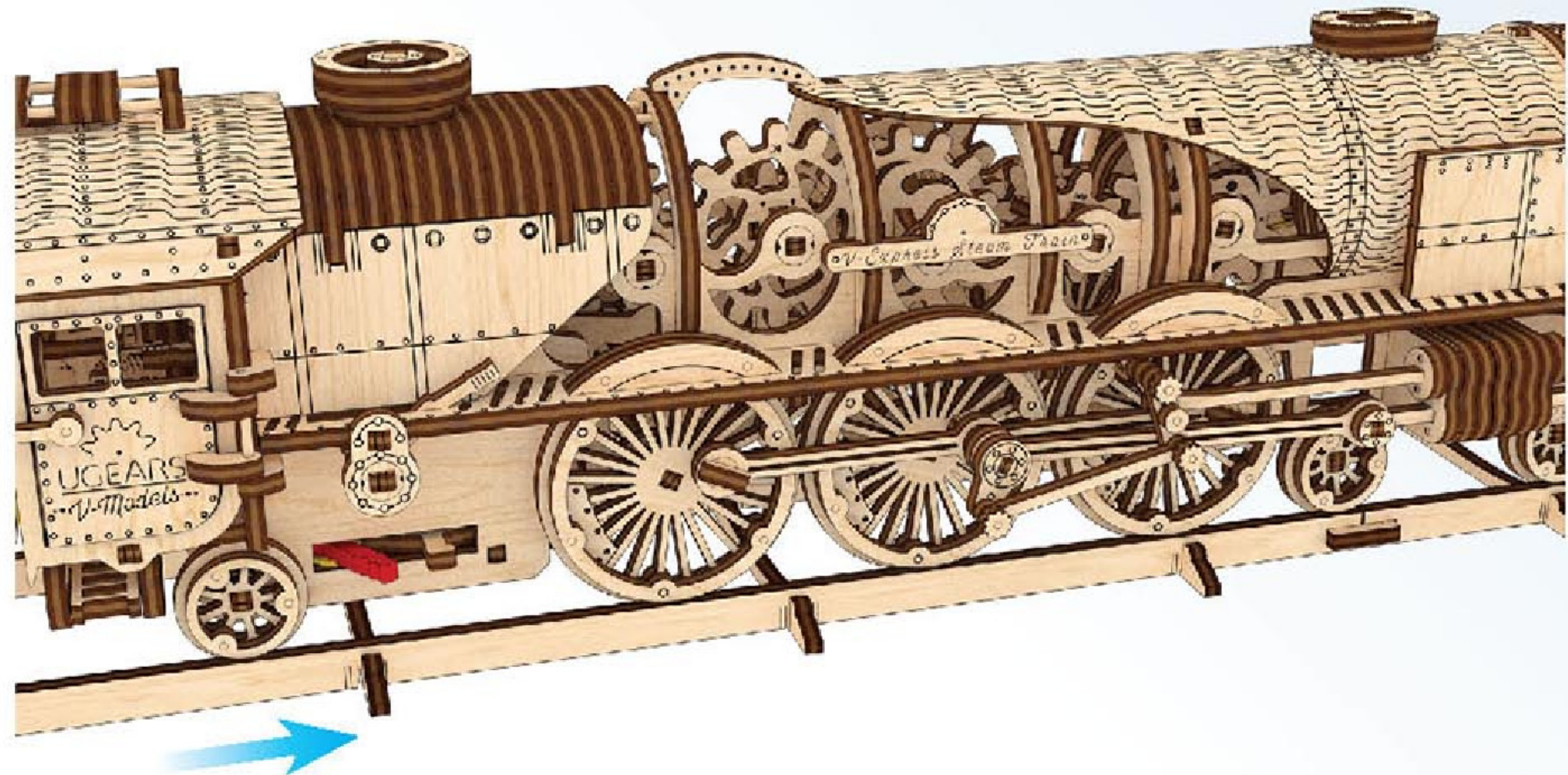

2

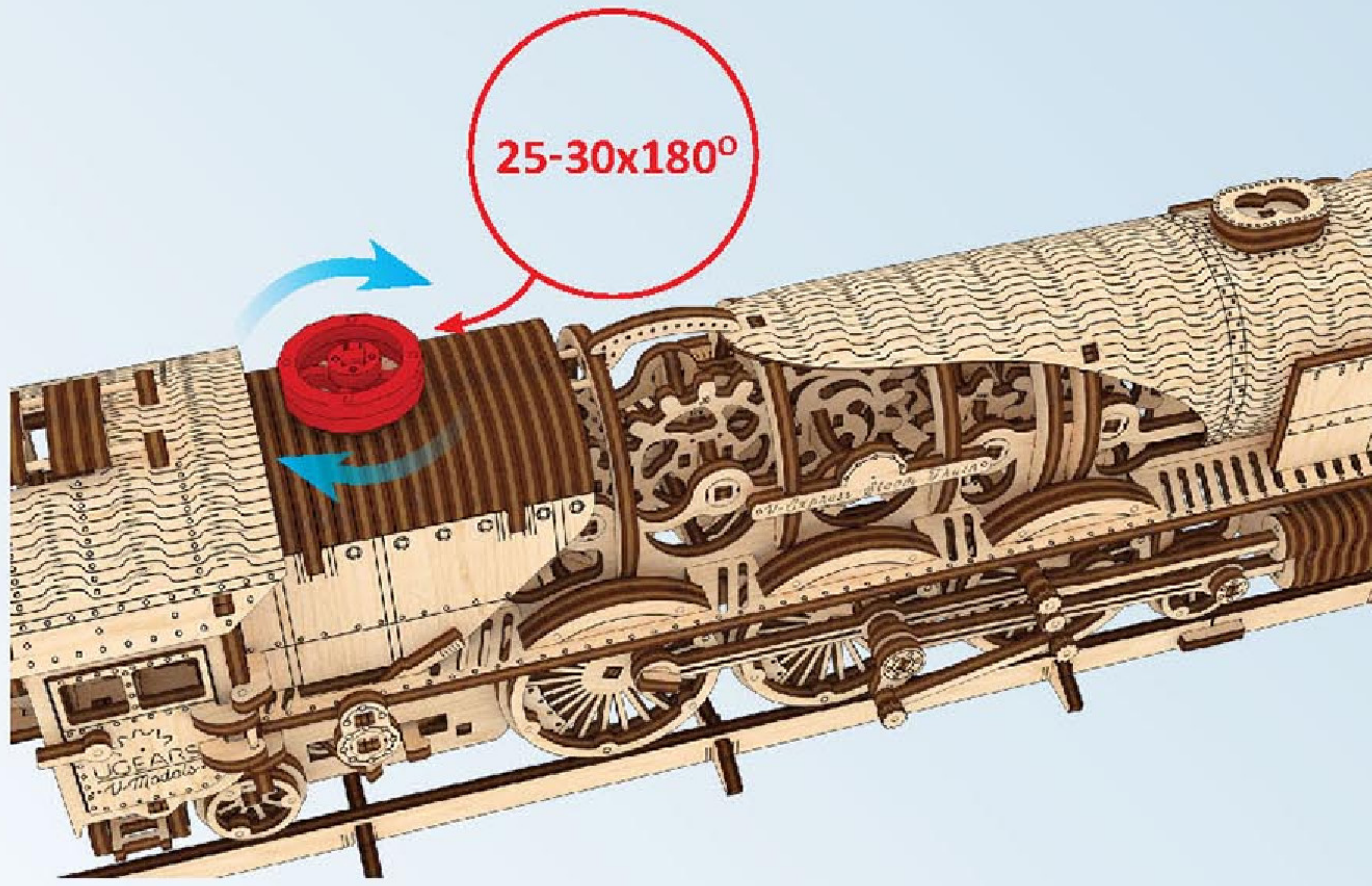

3

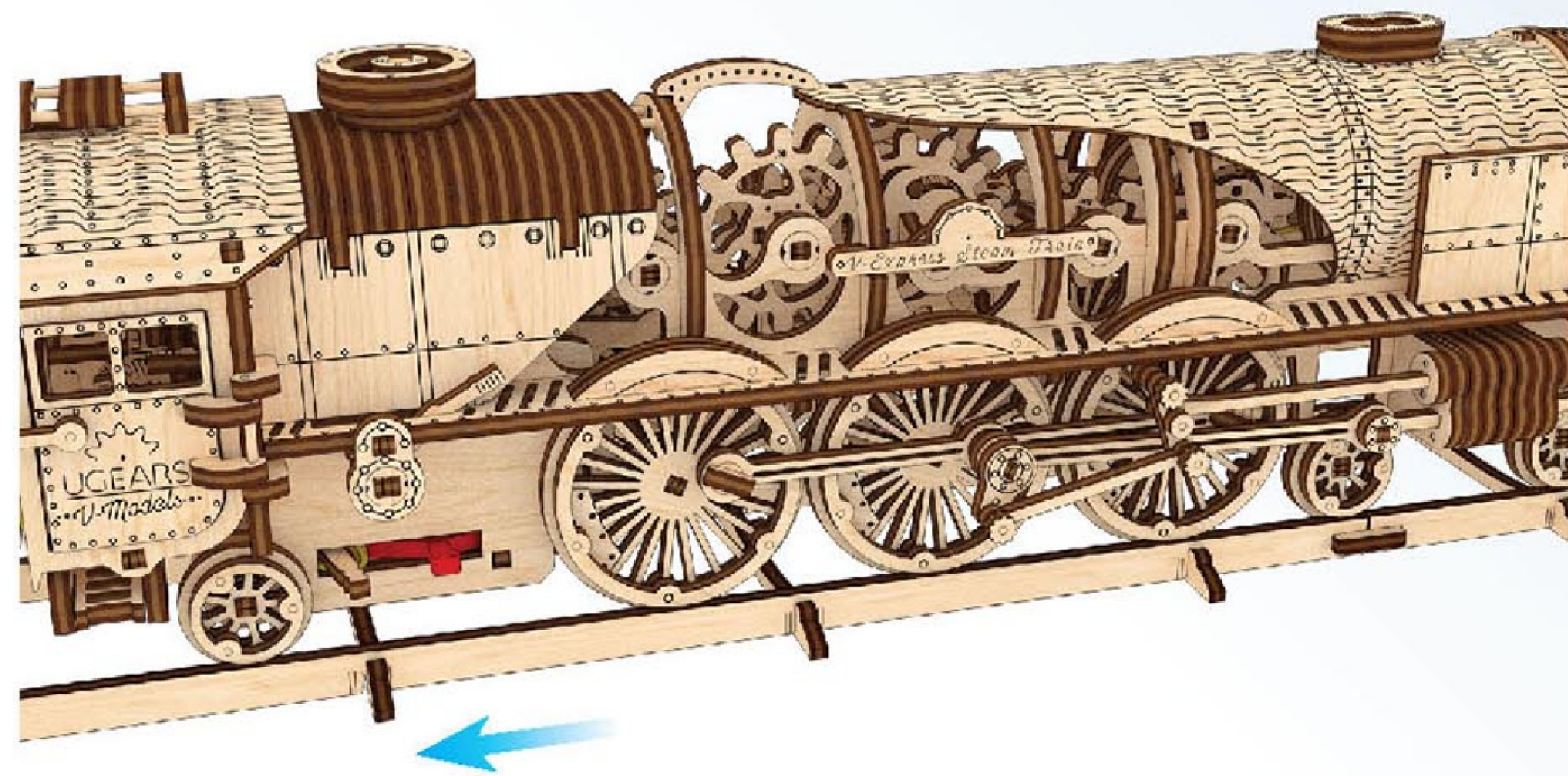

1

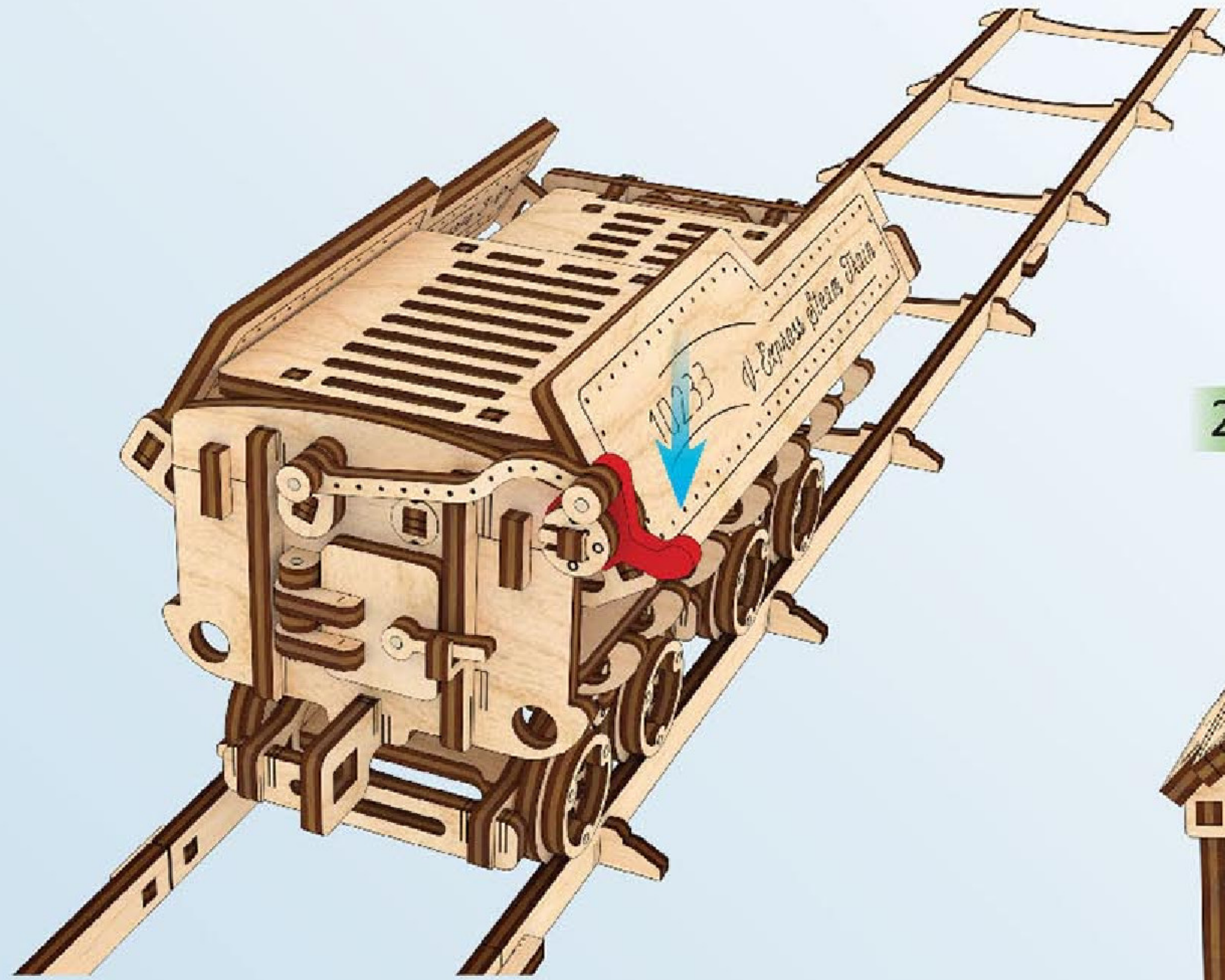

2



3

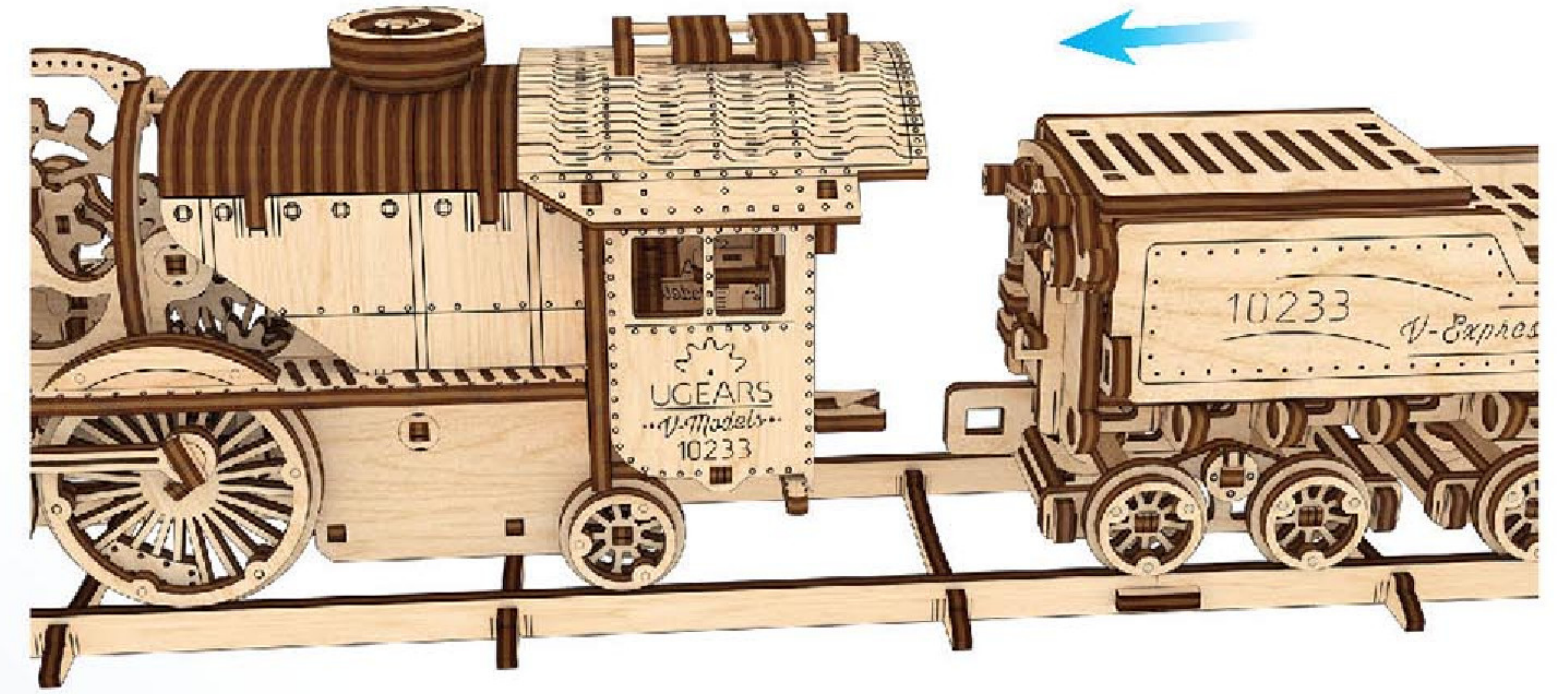

4

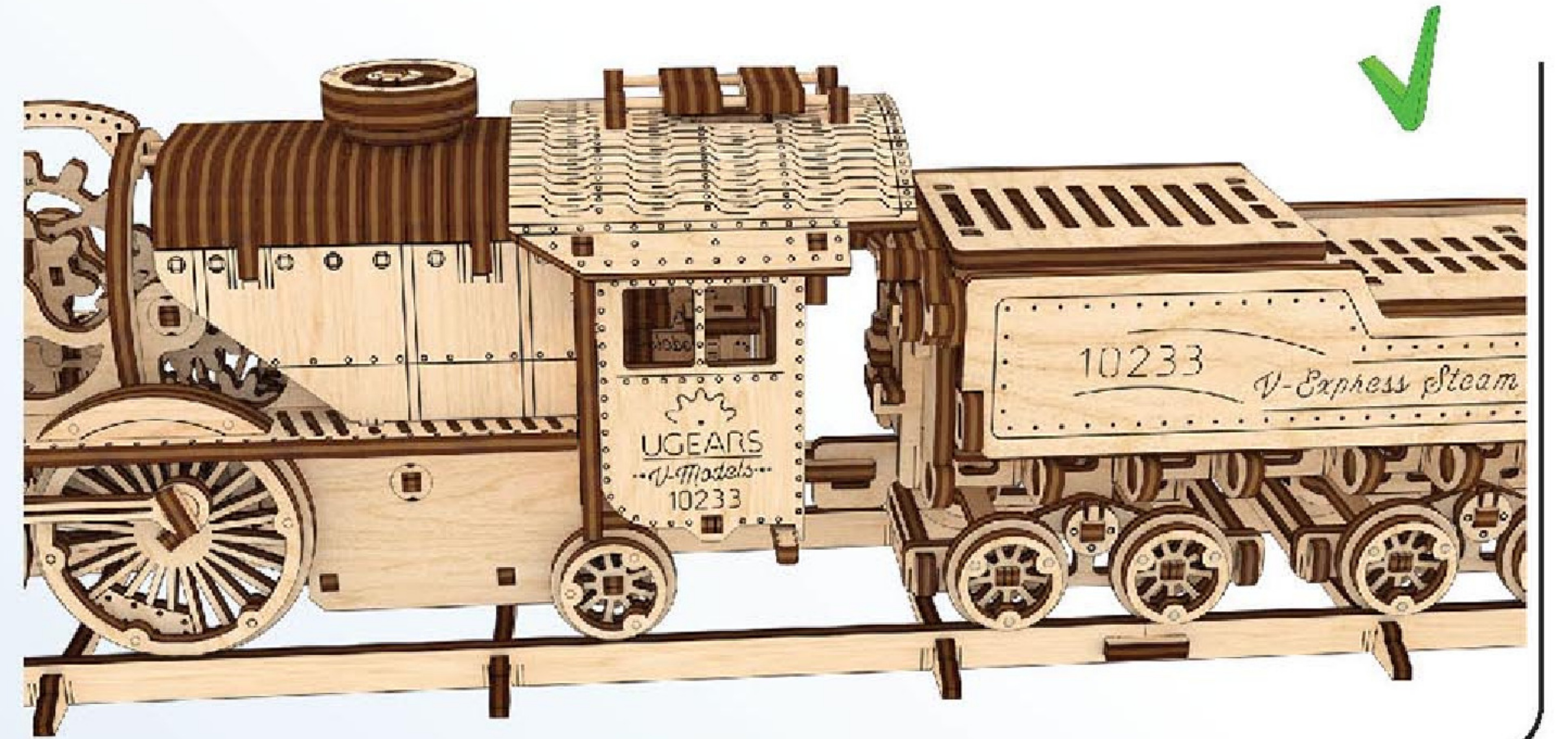

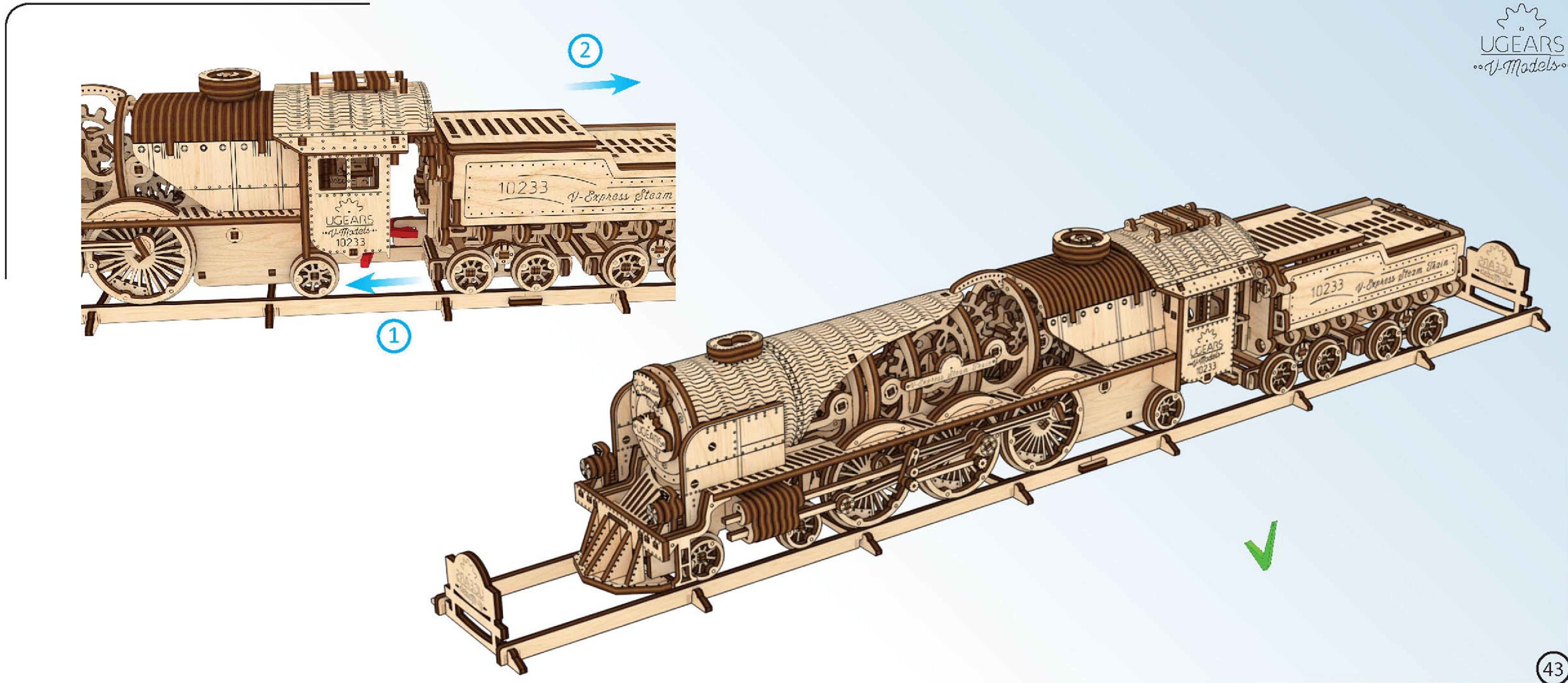



Watch the VIDEO

# Assemble Me. Travel Me



UGEARS®  
V-Models

Bedankt voor de deelname aan deze reis met ons.

[ugears-shop.nl](http://ugears-shop.nl)

